

## Installation, Operation, and Maintenance Instructions

This manual is the property of the owner, and is required for future maintenance. Please leave it with the owner when the job is complete.



### RECEIVING AND HANDLING

Upon receiving dampers, check for both obvious and hidden damage. If damage is found, record all necessary information on the bill of lading and file a claim with the final carrier. Check to be sure that all parts of the shipment, including accessories, are accounted for.

Dampers must be kept dry and clean. Indoor storage and protection from dirt, dust and the weather is highly recommended. Do not store at temperatures in excess of 100°F (37°C).

### SAFETY WARNING:

**Improper installation, adjustment, alteration, service or maintenance can cause property damage, injury or death. Read the installation, operating, and maintenance instructions thoroughly before installing or servicing this equipment.**



## Installation - Failure to follow instructions will void all warranties

1. Duct opening or opening square should measure  $\frac{1}{4}$  inch (6mm) larger than damper dimension and should be straight and level.

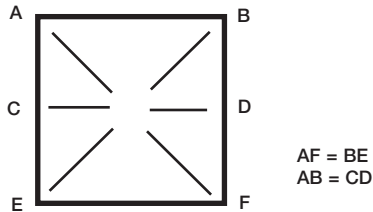

Do not twist or bow. Mount damper plumb in the opening.

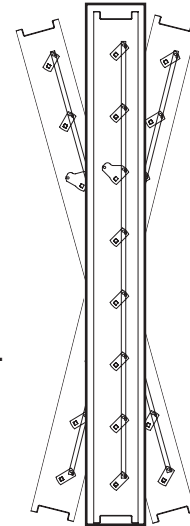

2. If more than two sections wide, unit ships as a multiple section assembly and a single section together. The single section is joined to the side of the multiple section where the jackshaft extends past the frame 4 inches (see Figure 1 & 2).
3. A damper assembly is not restricted to a maximum number of sections, but must not exceed the section sizes and overall sizes shown at the right.
4. The damper sections must be attached together with #10 x  $\frac{3}{4}$ in.(19mm) max. sheet metal screws,  $\frac{1}{4}$  in. (6mm) diameter nuts and bolts, tack or spot welds, or  $\frac{3}{16}$  in. (4mm) diameter steel pop rivets. Attachments must be spaced a maximum of 6 in. (152mm) on centers and a maximum of 2 in. (50mm) from corners. Attachments must be made on front face and back face (air entering and air exiting side) of damper sections.
5. Two section high dampers require reinforcement using a 14 gauge (2mm), 5 in. (127mm) wide mullion or two individually sleeved units stacked vertically. When using two individually sleeved units, the sleeve acts as the mullion, therefore no mullion is required (Mullions are not provided by Greenheck).

Damper Model	Maximum Single Section Size W x H in. (mm)	Maximum Overall Size for Multi-Section Dampers
VCD-15, VCD-18	48 x 60 (1219 x 1524)	84 in. W x 60 in. H (2133mm x 1524mm)
VCD-20, VCD-23	48 x 74 (1219 x 1880)	Unlimited
VCD-33, VCD-34, VCD-40, VCD-42, VCD-43	60 x 74 (1524 x 1880)	Unlimited
VCD-20V, VCD-23V	74 x 48 (1879 x 1219)	NA
VCD-33V, VCD-42V, VCD-43V	74 x 60 (1879 x 1524)	NA
FBH-43	Face: 60 x 74 (1524 x 1880) Bypass: 60 x 74 (1524 x 1880)	Face: 96 x 74 (2438 x 1880)
FBV-43	Face: 60 x 74 (1524 x 1880) Bypass: 60 x 74 (1524 x 1880)	Face: 96 x 74 (2438 x 1880) Bypass: 96 x 74 (2438 x 1880)

# Installation (continued)

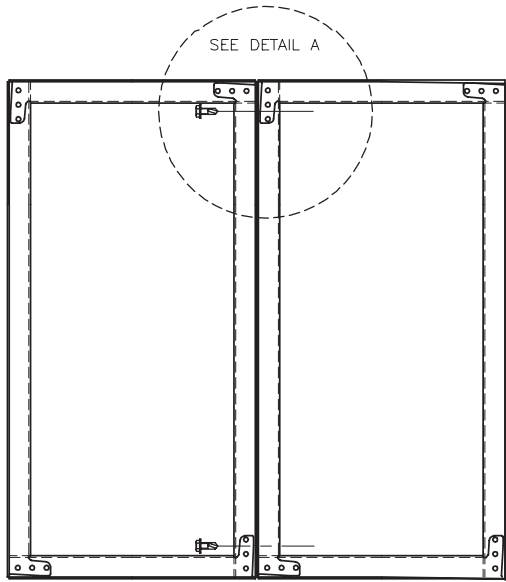

Figure 1

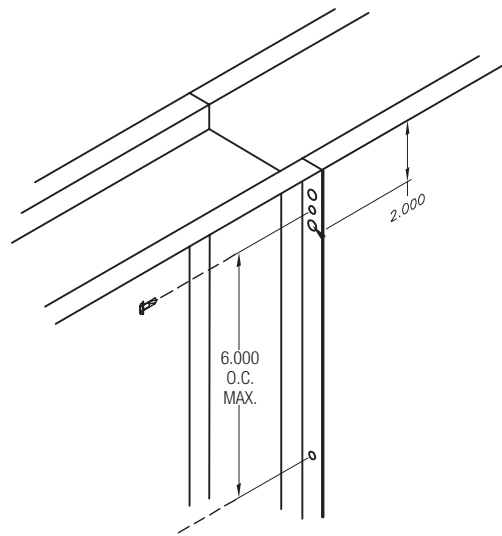
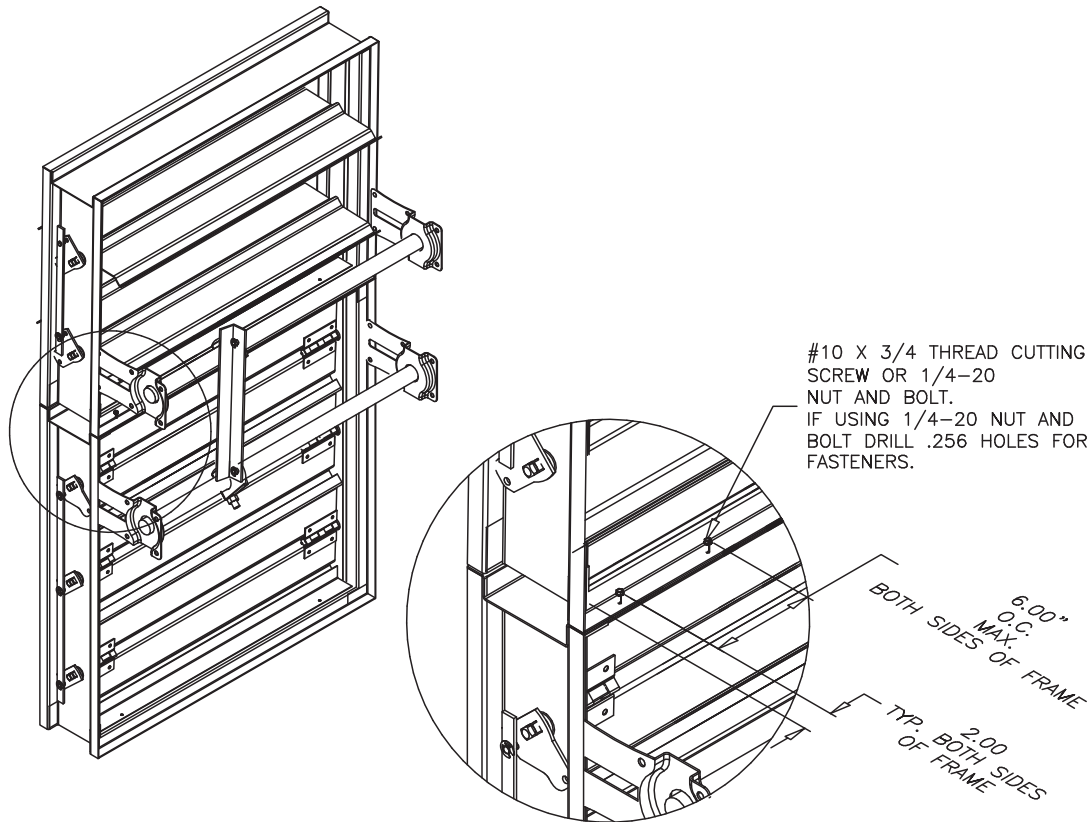

Figure 2

6. When the height of a Face & Bypass vertical style (FBV) is greater than 84 in. (2134mm), the damper sections are shipped separate and field assembly is required. Before fastening damper sections together, the non-actuated damper section will need to be flipped upside down so that the linkage is on the same side as the actuated damper. After damper sections are fastened together, attach interconnecting angle as shown in **Figure 3**. (Interconnecting angle is shipped with actuated damper section.)



FRAME FASTENING DETAIL

Figure 3

## Installation (continued)

---

7. If no holes are present in frame, drill ¼ inch (6mm) diameter holes at 6 inch (52mm) centers and fasten frames together with ¼ inch (6mm) #20 (.03mm) bolts and nuts (see Figure 1 & 2).
8. Use shims between damper frame and duct opening or opening space to prevent distortion of frame by fasteners holding it in place. Brace at every horizontal mullion and vertically brace at every 8 feet (2.4m) of damper width for strength. Dampers in high velocity (2000 fpm [610m per second]) may require more bracing. Note: Greenheck dampers are specifically designed and engineered for structural integrity based on model and conditions. Attachment, framing, mating flanges, and anchoring of damper assemblies into openings, ductwork, or walls is the responsibility of the installer. Design calculations for these retaining and supporting members should be determined by field engineers for that particular installation.
9. If damper actuator is to be mounted out of the airstream, the extension pin should extend approximately 6 inches (152mm) beyond the frame. On jackshafted units, the jackshaft should extend through the jackshaft bearing assembly and approximately, 6 inches (152mm) beyond the frame.
10. Individual damper sections, as well as entire multiple section assemblies must be completely square and free from racking, twisting, or bending. Measure diagonally from upper corners to opposite lower corners of each section.
11. Damper blades, axles, and linkage must operate without binding. Before system operation, cycle dampers after installation to assure proper operation. On multiple section assemblies, all sections should open and close simultaneously.

*Note: When you have a vertical damper installation, blades must be horizontal. When blades need to be vertical, you need a vertical blade damper (example: VCD-23V). These dampers are built so they don't crush the jamb seal.*

## Damper Maintenance

---

Greenheck's dampers are designed to be trouble free and hassle free under normal operation. Dampers are to be installed square and straight so as to prevent binding during operation. The following annual damper maintenance suggestions will help to insure proper damper operation and increase the life expectancy of the damper.

<b>Foreign Matter</b>	Over the course of time, dirt and grime may collect on damper surfaces. The damper surfaces should be cleaned to prevent hindrance to airflow.
<b>Moving Parts</b>	Make sure that parts such as linkage, bearings, blades, etc. that are intended to move freely, can do so. Lubricating these components can prevent possible rusting and unnecessary friction increase. Use only a moli-spray oil or similar graphite based oil as regular lubricating oil will attract dirt. <i>Bearings.</i> Synthetic, oil impregnated, and ball bearings (without grease fittings) do not require lubrication. Ball bearings with grease fittings require only minimal grease.
<b>Closure</b>	Remove foreign materials that may be interfering with blade closure or effective sealing of the blades with each other or with the frame.
<b>Operation</b>	While operating the damper through its full cycle, check to see that the blades open and close properly. If there is a problem, check for loose linkage, especially at the actuator. Tighten the linkage where required.

# Damper Trouble Shooting

The following is a cause and correction list for common concerns with the dampers.		
Symptom	Possible Cause	Corrective Action
Damper does not fully open and/or fully close	Frame is 'racked' causing blades to bind on jamb seals	Adjust frame such that it is square and plumb
	Actuator linkage loose	Close damper, disconnect power, adjust and tighten linkage
	Defective motor	Replace
	Screws in damper linkage	Locate screws and remove
	Actuator linkage hitting wall or floor	Damper installed too far into wall. Move out to line designated on damper label
	Contaminants on damper	Clean with a non oil-based solvent (see Damper Maintenance)
Actuator runs hot or makes a humming noise	Actuator type is MP-3754 or MP-3756 (stall type actuator)	None required since this normal for stall type actuators
	Actuator prohibited from reaching end of stroke	Disconnect linkage from jackshaft, open damper, power actuator to end of spring, tighten linkage. Verify amp draw.

## WARRANTY

Greenheck warrants this equipment to be free from defects in material and workmanship for a period of one year from the shipping date. Any units or parts which prove to be defective during the warranty period will be repaired or replaced at our option. Greenheck shall not be liable for damages resulting from misapplication or misuse of its products. Greenheck will not be responsible for any installation or removal costs. Greenheck will not be responsible for any service work or backcharges without prior written authorization.



Copyright © 2012 Greenheck Fan Corporation  
463384 VCD IOM Rev. 8 February 2012

P.O. Box 410 • Schofield, WI 54476-0410 • 715.359.6171 • greenheck.com