

Installation, Operation and Maintenance Manual

Please read and save these instructions for future reference. Read carefully before attempting to assemble, install, operate or maintain the product described. Protect yourself and others by observing all safety information. Failure to comply with instructions could result in personal injury and/or property damage!

Model NYD Direct Drive

Model NYD is a direct drive centrifugal roof exhaust fan. These fans are specifically designed for applications where tamper resistance is necessary. Performance capabilities range up to 3,000 cfm (5,097 m³/hr) and up to 1.0 in. wg (249 Pa) of static pressure. The maximum continuous operating temperature for fan sizes 075-140 is 180°F (82°C). NYD fans are available in six sizes with nominal wheel diameter ranging from 8 to 14 inches (203 to 356 mm) (075 - 140 unit sizes). Each fan shall bear a permanently affixed manufacturer's engraved metal nameplate containing the model number and individual serial number.

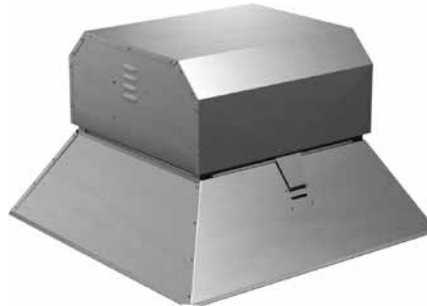

Model NYB Belt Drive

Model NYB is a belt drive centrifugal roof exhaust fan. These fans are specifically designed for applications where tamper resistance is necessary. Performance capabilities range up to 8,000 cfm (13,592 m³/hr) and up to 1.0 in. wg (249 Pa) of static pressure.

The maximum continuous operating temperature is 180°F (82°C). NYB fans are available in four sizes with nominal wheel diameter ranging from 11 to 24 inches (279 to 610 mm) (100 - 240 unit sizes). Each fan shall bear a permanently affixed manufacturer's engraved metal nameplate containing the model number and individual serial number.

General Safety Information

Only qualified personnel should install this fan. Personnel should have a clear understanding of these instructions and should be aware of general safety precautions. Improper installation can result in electric shock, possible injury due to coming in contact with moving parts, as well as other potential hazards. Other considerations may be required if high winds or seismic activity are present. If more information is needed, contact a licensed professional engineer before moving forward.

1. Follow all local electrical and safety codes, as well as the National Electrical Code (NEC) and the National Fire Protection Agency (NFPA), where applicable. Follow the Canadian Electric Code (CEC) in Canada.
2. The rotation of the wheel is critical. It must be free to rotate without striking or rubbing any stationary objects.
3. Motor must be securely and adequately grounded.
4. Do not spin fan wheel faster than max cataloged fan RPM. Adjustments to fan speed significantly effects motor load. If the fan RPM is changed, the motor current should be checked to make sure it is not exceeding the motor nameplate amps.
5. Do not allow the power cable to kink or come in contact with oil, grease, hot surfaces, or chemicals. Replace cord immediately if damaged.
6. Verify that the power source is compatible with the equipment.
7. Never open access doors to a duct while the fan is running.

DANGER

Always disconnect, lock and tag power source before installing or servicing. Failure to disconnect power source can result in fire, shock or serious injury.

CAUTION

When servicing the fan, motor may be hot enough to cause pain or injury. Allow motor to cool before servicing.

CAUTION

Precaution should be taken in explosive atmospheres.

Receiving

Upon receiving the product, check to make sure all items are accounted for by referencing the bill of lading to ensure all items were received. Inspect each crate for shipping damage before accepting delivery. Notify the carrier if any damage is noticed. The carrier will make notification on the delivery receipt acknowledging any damage to the product. All damage should be noted on all the copies of the bill of lading which is countersigned by the delivering carrier. A Carrier Inspection Report should be filled out by the carrier upon arrival and reported to the Traffic Department. If damaged upon arrival, file a claim with carrier. Any physical damage to the unit after acceptance is not the responsibility of Greenheck Fan Corporation.

Unpacking

Verify that all required parts and the correct quantity of each item have been received. If any items are missing, report shortages to your local representative to arrange for obtaining missing parts. Sometimes it is not possible that all items for the unit be shipped together due to availability of transportation and truck space. Confirmation of shipment(s) must be limited to only items on the bill of lading.

Handling

Move fan to desired location and fasten securely through mounting holes in base. Shims may be necessary depending upon roofing material thickness. The following diagram depicts dimensions for models NYD and NYB.

CAUTION

Do not lift by the fan hood. Avoid lifting fans in a way that will bend or distort fan parts. Never pass slings or timbers through the venturi of fan. Fans with special coatings or paints must be protected in handling to prevent damage.

A heavy-gauge stainless steel hasp allows the unit to be padlocked for security. The hasp design conceals the padlock beneath the housing skirt, which keeps it out of sight and the weather.

The motor's amperage and voltage ratings must be checked for compatibility to supply voltage prior to final electrical connection. Electrical lead-in wires should be run through the conduit provided between the curb and the bottom of the motor compartment. Wiring must conform to local and national codes.

Storage

Fans are protected against damage during shipment. If the unit cannot be installed and operated immediately, precautions need to be taken to prevent deterioration of the unit during storage. The user assumes responsibility of the fan and accessories while in storage. Greenheck Fan Corporation will not be responsible for damage during storage. These suggestions are provided solely as a convenience to the user.

Indoor

The ideal environment for the storage of fans and accessories is indoors, above grade, in a low humidity atmosphere which is sealed to prevent the entry of blowing dust, rain or snow. Temperatures should be evenly maintained between 30° to 110°F (-1° to 43°C) (wide temperature swings may cause condensation and "sweating" of metal parts). All accessories must be stored indoors in a clean, dry atmosphere.

Remove any accumulations of dirt, water, ice, or snow and wipe dry before moving to indoor storage. To avoid "sweating" of metal parts, allow cold parts to reach room temperature. To dry parts and packages use a portable electric heater to get rid of any moisture buildup. Leave coverings loose to permit air circulation and to allow for periodic inspection.

Table 1: Dimensional Data

Model	A	B	C	Damper Square	Roof Opening	Approximate Weight
NYD-75	19 (483)	30¾ (781)	20½ (521)	10 (254)	12½ (318)	62 (28)
NYD-90	19 (483)	30¾ (781)	20½ (521)	10 (254)	12½ (318)	75 (34)
NYD/NYB-100	22 (559)	35½ (902)	25 (635)	12 (305)	14½ (368)	95 (43)
NYD-120	24 (610)	37 (940)	23⅞ (587)	14 (356)	16½ (419)	95 (43)
NYD-130	24 (610)	37 (940)	23⅞ (587)	14 (356)	16½ (419)	105 (48)
NYD/NYB-140	26 (660)	41½ (1054)	26⅞ (683)	16 (406)	18½ (470)	135 (61)
NYB-180	30 (762)	45 (1143)	32⅝ (829)	18 (457)	20½ (521)	225 (102)
NYB-240	34 (864)	52½ (1334)	38⅞ (981)	24 (610)	26½ (673)	314 (142)

All dimensions in inches (millimeters). Weight in pounds (kilograms).

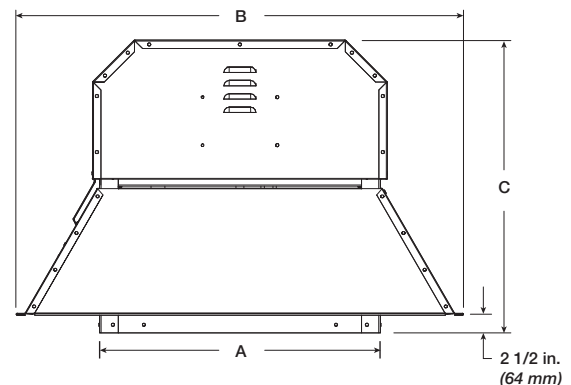

Figure 1

The unit should be stored at least 3½ inches (89 mm) off the floor on wooden blocks covered with moisture proof paper or polyethylene sheathing. Aisles between parts and along all walls should be provided to permit air circulation and space for inspection.

Outdoor

Fans designed for outdoor applications may be stored outdoors, if absolutely necessary. Roads or aisles for portable cranes and hauling equipment are needed.

The fan should be placed on a level surface to prevent water from leaking into the fan. The fan should be elevated on an adequate number of wooden blocks so that it is above water and snow levels and has enough blocking to prevent it from settling into soft ground. Locate parts far enough apart to permit air circulation, sunlight and space for periodic inspection. To minimize water accumulation, place all fan parts on blocking supports so that rain water will run off.

Do not cover parts with plastic film or tarps as these cause condensation of moisture from the air passing through heating and cooling cycles.

Fan wheels should be blocked to prevent spinning caused by strong winds.

Inspection and Maintenance During Storage

While in storage, inspect fans once per month. Keep a record of inspection and maintenance performed.

If moisture or dirt accumulations are found on parts, the source should be located and eliminated. At each inspection, rotate the wheel by hand ten to fifteen revolutions to distribute lubricant on motor. If paint deterioration begins, consideration should be given to touch-up or repainting. Fans with special coatings may require special techniques for touch-up or repair.

Machined parts coated with rust preventive should be restored to good condition promptly if signs of rust occur. Immediately remove the original rust preventive coating with petroleum solvent and clean with lint-free cloths. Polish any remaining rust from surface with crocus cloth or fine emery paper and oil. Do not destroy the continuity of the surfaces. Thoroughly wipe clean with Tectyl® 506 (Ashland Inc.) or the equivalent. For hard to reach internal surfaces or for occasional use, consider using Tectyl® 511M Rust Preventive, WD-40® or the equivalent.

Removing From Storage

As fans are removed from storage to be installed in their final location, they should be protected and maintained in a similar fashion until the fan equipment goes into operation.

Pre-Starting Checks

1. Check all fasteners and setscrews for tightness. The wheel should rotate freely and be aligned as shown in figure 2.

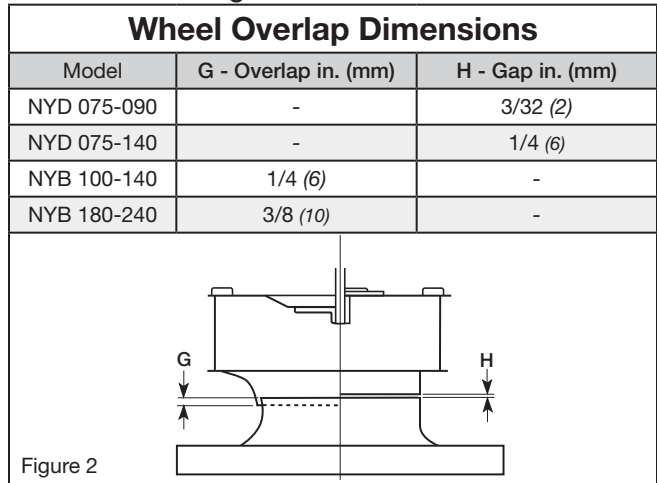

2. Wheel position is preset and the unit is test run at the factory. Movement may occur during shipment and realignment may be necessary.
3. Centering can be accomplished by loosening the bolts holding the drive frame to the shock mounts and repositioning the drive frame.
4. Wheel and inlet cone overlap can be adjusted by loosening the setscrews in the wheel and moving the wheel to the desired position.
5. Check wheel rotation by momentarily energizing the unit. Rotation should be clockwise as shown in figure 3 and correspond to the rotation decal on the unit. Rotation is determined when the unit is viewed from the motor or shaft pulley side. If wheel rotation is incorrect reverse two of the wiring leads or check motor wiring for single-phase.

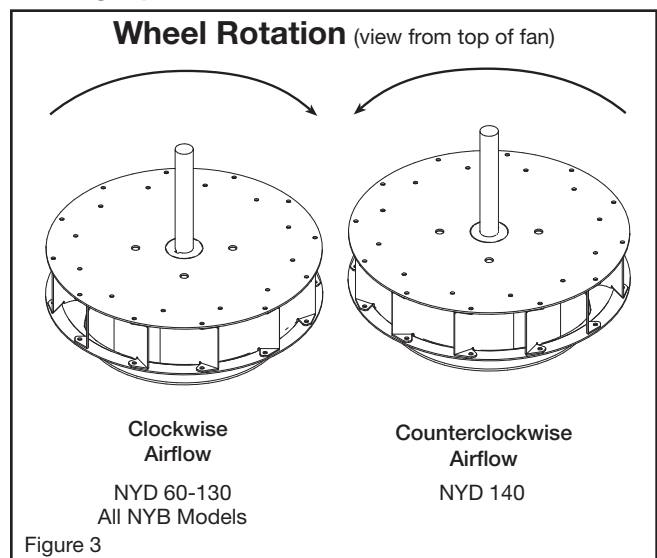

WARNING

Correct direction of wheel rotation is critical. Reversed rotation will result in poor air performance, motor overloading and possible burnout.

Model NYB Pre-Starting Belt Tension Checks

- Always loosen tension enough to install belts without stretching, see figure 4.

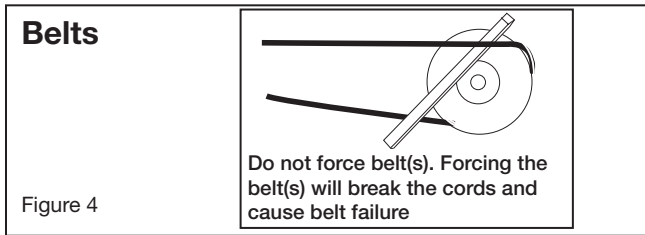

- For units with two groove pulleys, adjust so the tension is equal in both belts.
- If adjustments are made, it is very important to check the pulleys for proper alignment. Misaligned pulleys lead to excessive belt wear vibration, noise and power loss, see figure 5.

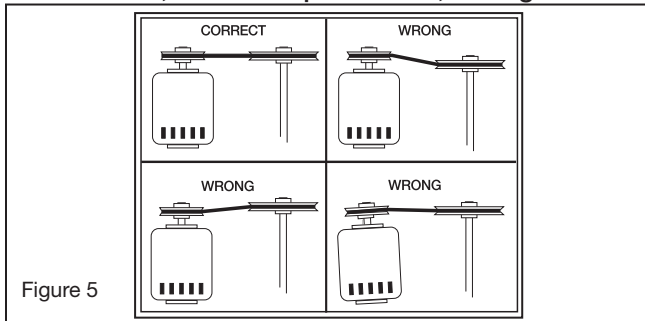

- Belt tension can be adjusted by loosening four fasteners on the drive frame, see figure 6. This allows the motor plate to slide on the drive frame angles for proper positioning.

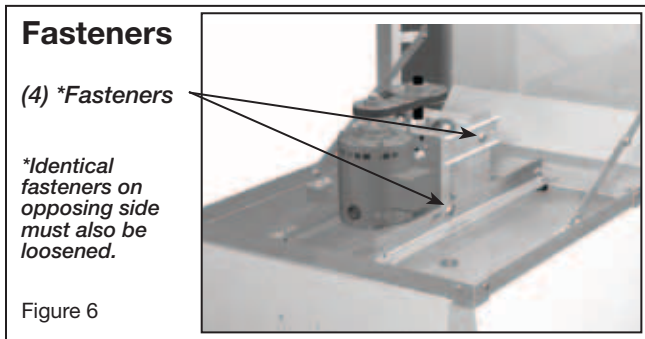

- Belt tension should be adjusted to allow 1/64 inch (0.397 mm) of deflection per inch of belt span. For example, a 15 inch (381 mm) belt span should have 15/64 inch (0.234 mm) (or about 1/4 inch (6 mm)) of deflection with moderate thumb pressure at mid-point between pulleys, see figure 7.

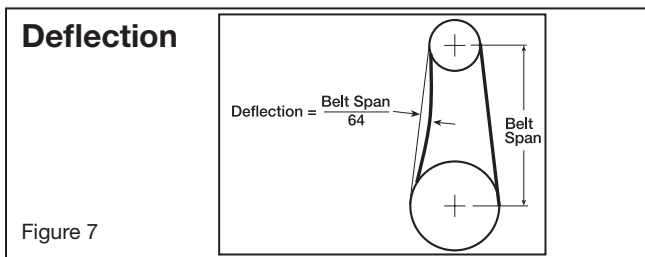

- The adjustable motor pulley is factory set for the RPM specified. Speed can be increased by closing or decreased by opening the adjustable motor pulley. Two groove variable pitch pulleys must be adjusted an equal number of turns open or closed.
- Any increase in speed represents a substantial increase in the horsepower required by the unit.
- Motor amperage should always be checked to avoid serious damage to the motor when speed is varied.

WARNING

The fan has been checked for mechanical noises at the factory prior to shipment. If mechanical noise should develop, suggested corrective actions are offered in the Troubleshooting section.

IMPORTANT

Over tightening will cause excessive bearing wear and noise. Too little tension will cause slippage at start-up and uneven wear.

Operation: NYD/NYB

- Before starting or operating fan, check all fasteners for tightness. In particular, check the setscrews in wheel hub (and pulleys, if applicable).
- While in the OFF position or before connecting the fan to power, turn the fan wheel by hand to be sure it is not striking the venturi or any obstacle.
- Start the fan and shut it off immediately to check rotation of the wheel with directional arrow in the motor compartment, see figure 3 on page 3.
- When the fan is started, observe the operation and check for any unusual noises.
- With the system in full operation and all ductwork attached, measure current input to the motor and compare with the nameplate rating to determine if the motor is operating under safe load conditions.
- Keep inlets and approaches to fan clean and free from obstruction.

Inspection: NYD/NYB

Inspection of the fan should be conducted at the first 30 minute and 24 hour intervals of satisfactory operation.

30 Minute Interval

Inspect bolts, setscrews and motor mounting bolts. Adjust and tighten as necessary.

24 Hour Interval

Check all internal components. On NYB unit only, inspect belt alignment and tension. Adjust and tighten as necessary.

IMPORTANT

Adjust (tighten) belt tension after the first 24-48 hours of operation.

Maintenance: NYD/NYB

A proper maintenance program will help these units deliver years of dependable service. Installation and maintenance are to be performed only by qualified personnel who are familiar with local codes and regulations and who are experienced with this type of equipment.

Motor maintenance is generally limited to cleaning and lubrication (where applicable). Cleaning should be limited to exterior surfaces only. Removing dust buildup on motor housing ensures proper motor cooling.

Greasing of motors is only intended when fittings are provided. Many fractional horsepower motors are permanently lubricated and should not be lubricated after installation. Motors supplied with grease fittings should be greased in accordance with manufacturers' recommendations. Where motor temperatures do not exceed 104°F (40°C), the grease should be replaced after 2,000 hours of running time as a general rule.

Direct drive units require little maintenance except for cleaning wheel, alignment and oiling according to motor label instructions.

The unit should be made non-functional when cleaning the wheel or housing (fuses removed, disconnect locked off, etc.).

Wheels require very little attention when moving clean air. Occasionally, oil and dust may accumulate causing imbalance. When this occurs the wheel and housing should be cleaned to ensure smooth and safe operation.

All fasteners should be checked for tightness each time maintenance checks are performed prior to restarting unit.

A proper maintenance program will help these units deliver years of dependable service.

Belt/Bearing Maintenance NYB Unit

1. Belts tend to stretch after a period of time. They should be checked periodically for wear and tightness. When replacing belts, use the same type as supplied with the unit.
2. Matched belts should always be used on units with multi-groove pulleys.
3. For belt replacement, loosen the tensioning device enough to allow removal of the belt by hand. Do not force the belts on or off. This may cause cords to break, leading to premature failure.
4. Once installed, adjust belts as shown in "Pre-Starting Checks."

5. Shaft bearings can be classified in two groups: relubricating and non-relubricating. All bearings are factory lubricated and require no further lubrication under normal use (between -20°F and 180°F in a relatively clean environment).
6. Units installed in hot, humid or dirty locations should be equipped with special bearings. These bearings will require frequent lubrication.
7. On NYB belt driven fans, the standard cast pillow block bearings are factory lubricated and are provided with external grease fittings. Annual lubrication is recommended, or more frequently if needed, see Table 2. Do not over-grease. Use only one or two shots of lubricant with a hand gun. Maximum hand gun rating is 40 psi. Rotate bearings during lubrication where good safety practice permits. Caution should be employed to prevent over packing or contamination.
7. Grease fittings should be wiped clean. The unit should be in operation while lubricating. Extreme care should be used around moving parts.
8. Grease should be pumped in very slowly until a slight bead forms around the seal. A high grade lithium base grease should be used.
9. To ensure tightness, check pulley setscrews. Proper keys must be in keyways.
10. Fan RPM should not be readjusted. Only use pulleys of identical size and type when replacing pulleys.
11. During the first few months of operation check bearing setscrews periodically to ensure tightness.
12. If unit is to be left idle for an extended period, remove belts and store in a cool, dry place to avoid premature belt failure.

WARNING

Always disconnect, lock and tag power source before servicing. Failure to disconnect power source can result in fire, shock or serious injury.

CAUTION

Uneven cleaning of the wheel will produce an out of balance condition that will cause vibration in the fan.

WARNING

This unit should be made non-functional when cleaning the wheel or housing (fuses removed, disconnect locked off).

Recommended Relubrication Frequency in Months

NOTE: If unusual environment conditions exist more frequent lubrication is required (extreme temperature, moisture or contaminants).

A good quality lithium base grease, conforming to NLGI Grade 2 consistency, such as those listed here may be used.

Interval (months)	Type of Service
1 to 3	Heavy duty in dirty, dusty locations; high ambient temperatures; moisture laden atmosphere; vibration.
3 to 6	12 to 24 hours per day, heavy duty, or if moisture is present
6 to 12	8 to 16 hours per day in clean, relatively dry atmosphere
12 to 18	Infrequent operation or light duty in clean atmosphere

Manufacturer	Grease (NLGI #2)
U.S. Electric Motors	Grease No. 83343
Chevron U.S.A. Inc	Chevron SRI Grease #2
Mobil Oil Corporation	Mobilith
	Mobil 532
Texaco, Inc.	Premium BRB #2
	Texaco Multifak #2
Amoco Oil Co.	Rykon Premium #2
Exxon	Unirex N2
Shell	B Shell Alvania #2

Troubleshooting

WARNING: Before taking any corrective action, make certain unit is not capable of operation during repairs.

PROBLEM	CAUSE	CORRECTIVE ACTION
Excessive Noise or Vibration	Bad Bearings	Replace.
	Wheel unbalance	Clean and remove all dirt buildup off wheel. Check wheel balance, rebalance in place if necessary.
	Belts too tight or too loose	Adjust tension, see figure 7.
	Wheel improperly aligned and rubbing	Center wheel on inlet, see figure 2.
	Loose drive or motor pulleys	Align and tighten. See "Pre-Starting Checks", see page 3-4.
	Foreign objects in wheel or housing	Remove objects, check for damage or unbalance.
Reduced airflow	System resistance too high	Check system: Proper operation of backdraft or control dampers, obstruction in ductwork, etc.
	Unit running backwards	Correct as shown in figure 3.
	Excessive dirt buildup on wheels	Clean wheel.
	Improper wheel alignment	Center wheel on inlets, see Pre-Starting checks and figure 2.

Parts List

NOTE: Each fan bears a manufacturer's nameplate with model number and serial number embossed. This information will assist the local Greenheck representative and the factory in providing service and replacement parts. Before taking any corrective action, make certain unit is not capable of operation during repairs.

CAUTION: A fan manufactured with an explosion resistant motor does not certify the entire unit to be explosion proof.

NYB Belt Drive Centrifugal Roof Exhaust Fan

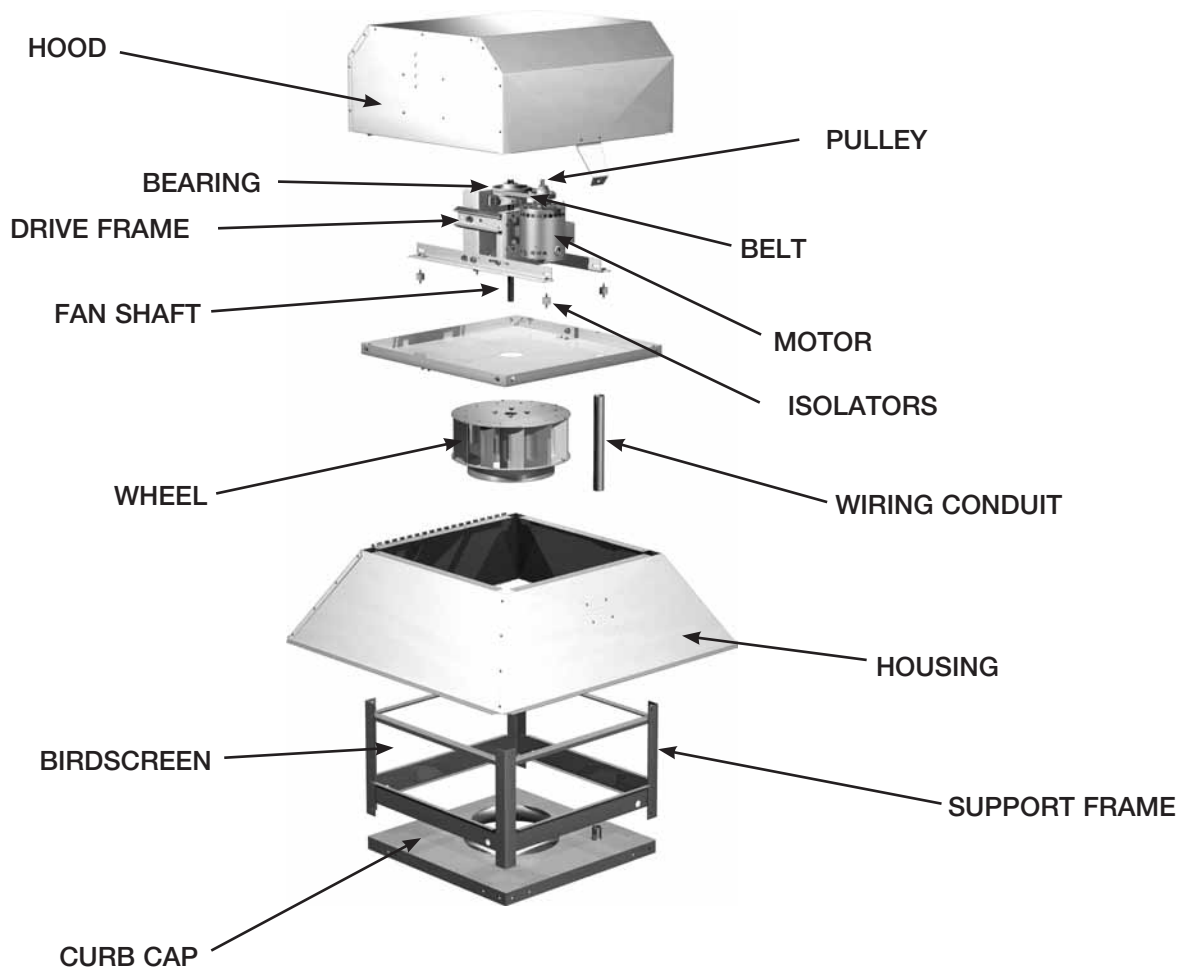

Parts List

NOTE: Each fan bears a manufacturer's nameplate with model number and serial number embossed. This information will assist the local Greenheck representative and the factory in providing service and replacement parts. Before taking any corrective action, make certain unit is not capable of operation during repairs.

CAUTION: A fan manufactured with an explosion resistant motor does not certify the entire unit to be explosion proof.

NYD Direct Drive Centrifugal Roof Exhaust Fan

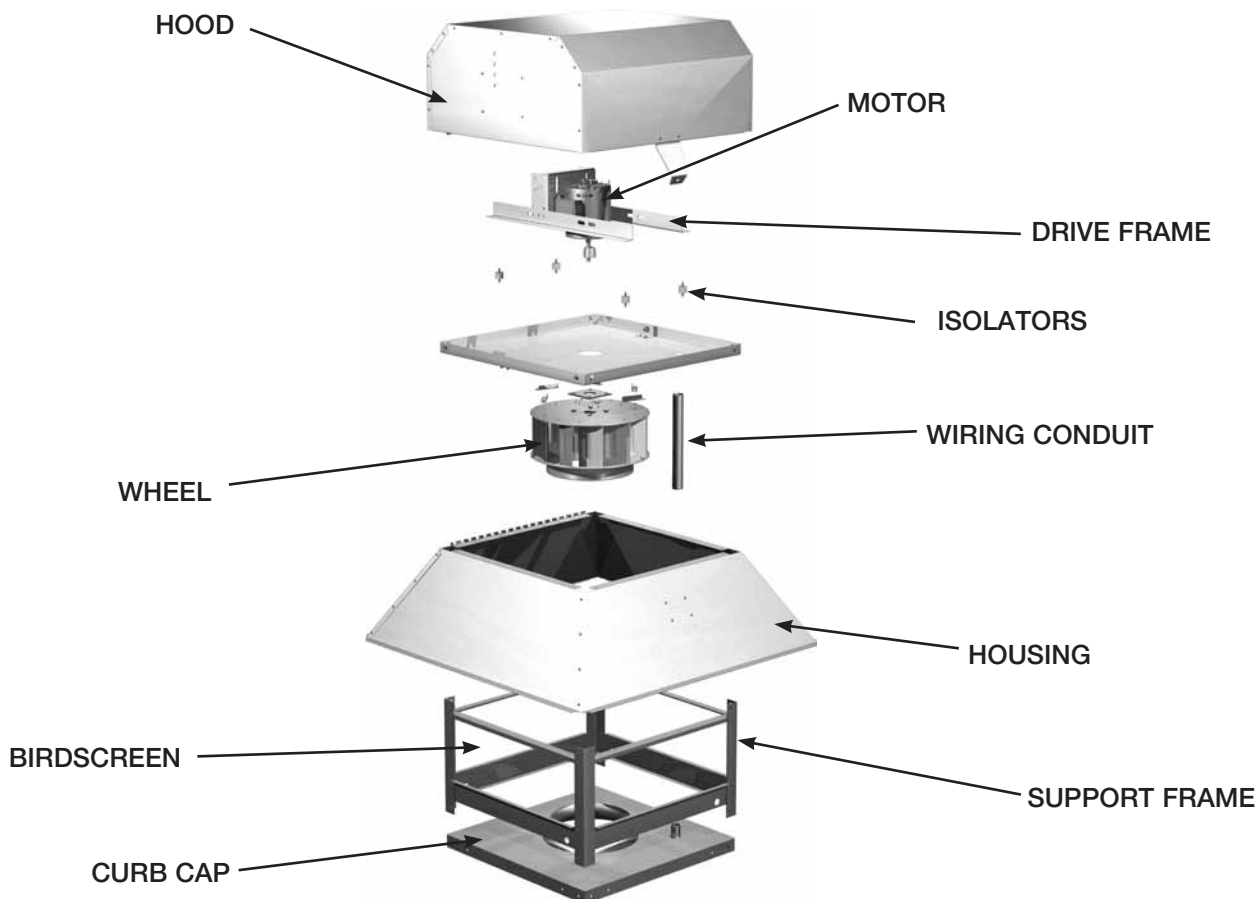

Warranty

Greenheck warrants this equipment to be free from defects in material and workmanship for a period of one year from the purchase date. Any units or parts which prove defective during the warranty period will be replaced at our option when returned to our factory, transportation prepaid. Motors are warranted by the motor manufacturer for a period of one year. Should motors furnished by Greenheck prove defective during this period, they should be returned to the nearest authorized motor service station. Greenheck will not be responsible for any removal or installation costs.

As a result of our commitment to continuous improvement, Greenheck reserves the right to change specifications without notice.

Greenheck Catalog NYD & NYB provides additional information describing the equipment, fan performance, available accessories, and specification data.

AMCA Publication 410-96, Safety Practices for Users and Installers of Industrial and Commercial Fans, provides additional safety information. This publication can be obtained from AMCA International, Inc. at: www.amca.org.



Phone: (715) 359-6171 • Fax: (715) 355-2399 • E-mail: gfcinfo@greenheck.com • Website: www.greenheck.com