

## ***Installation, Operation and Maintenance Instructions***

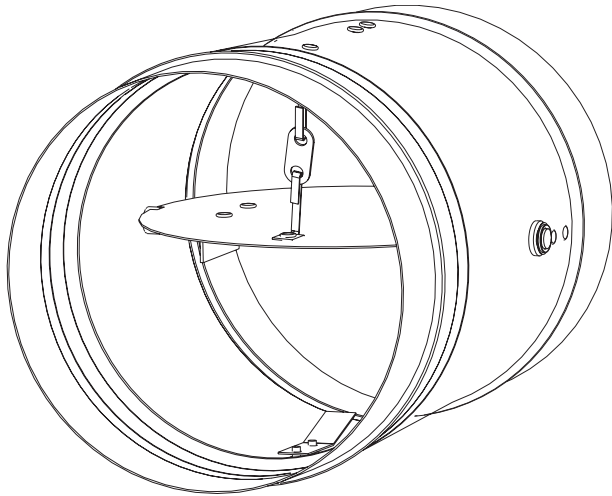

DFDR-XXX, SSDFDR-XXX, FDR-XXX, and SSFDR-XXX Model Dampers are intended for installation in accordance with fire damper requirements established by:

**National Fire Protection Association**  
NFPA Standards 80, 90A, 101 and 105  
**IBC International Building Codes**  
**New York City** (MEA listing #260-91-M)



**“UL CLASSIFIED (see complete marking on product)”**  
**“UL CLASSIFIED to Canadian safety standards (see complete marking on product)”**  
UL Standard 555 (Classification #R13317)

### **RECEIVING AND HANDLING**

Upon receiving dampers, check for both obvious and hidden damage. If damage is found, record all necessary information on the bill of lading and file a claim with the final carrier. Check to be sure that all parts of the shipment, including accessories, are accounted for.

Dampers must be kept dry and clean. Indoor storage and protection from dirt, dust and the weather is highly recommended. Do not store at temperatures in excess of 100°F (37°C).

### **SAFETY WARNING:**

**Improper installation, adjustment, alteration, service or maintenance can cause property damage, injury or death. Read the installation, operating, and maintenance instructions thoroughly before installing or servicing this equipment.**

### **INSTALLATION SUPPLEMENTS**

Refer to the appropriate Greenheck installation supplements for special requirements:

- Steel Deck Supplement

### **WARRANTY**

Greenheck warrants this equipment to be free from defects in material and workmanship for a period of one year from the shipment date. Any units or parts which prove to be defective during the warranty period will be repaired or replaced at our option. Greenheck shall not be liable for damages resulting from misapplication or misuse of its products. Greenheck will not be responsible for any installation or removal costs. Greenheck will not be responsible for any service work or backcharges without prior written authorization.

Due to continuing research, Greenheck reserves the right to change specifications without notice.

This manual is the property of the owner, and is required for future maintenance. Please leave it with the owner when the job is complete.

# Table of Contents

Pre-Installation Guidelines .....	2
Installation .....	2-4
Maintenance .....	4
Troubleshooting .....	4

## Pre-Installation Guidelines

The basic intent of a proper installation is to secure the fire damper in the opening in such a manner as to prevent distortion and disruption of damper operation. This is accomplished by allowing the fire damper in rated separation openings to expand and for the connecting duct to separate in the event of the collapse of the hanging system. The following items will aid in completing the damper installation in a timely and effective manner.

- 1) Check the schedules for proper damper locations within the building. Visually inspect the damper for damage and verify that the fusible link is in place or has not separated. Dampers will be supplied with a temperature responsive fusible link device. If fusible link is not present or has separated, replace link. Never install a fire damper without the proper UL approved fusible link in place.
- 2) Lift or handle damper using the frame. Do not lift damper using blades.
- 3) Do not install screws into the main body area of the damper frame as screws may interfere with and prevent damper blade from opening and/or closing.
- 4) Damper must be installed into duct or opening free of distortion or other misalignment. Damper must not be squeezed or stretched into duct or opening. Out of round, racked, twisted or misaligned installations can cause torque requirements to exceed damper design.
- 5) Damper must be kept clean and protected from dirt, dust and other foreign materials prior to and after installation. Examples of such foreign materials include but are not limited to: 1) Mortar dust 2) Drywall dust 3) Firesafing materials 4) Wall texture and 5) Paint overspray.
- 6) Damper should be sufficiently covered to prevent overspray if wall texturing or spray painting will be performed within 5 feet of the damper. Excessive dirt or foreign material deposits on damper can cause torque requirements to exceed damper design.
- 7) Caulking is not allowed between the damper sleeve and the wall or floor opening (annular space). However, caulking may be applied to the retaining plates and a field-applied sealant may be required for the damper sleeve and transitions to meet certain duct leakage standards.
- 8) ACCESS: Suitable access (such that fusible links can be maintained) must be provided for damper inspection and servicing. Where it is not possible to achieve sufficient size access, it will be necessary to install a removable section of duct. (Refer to NFPA 90A).
- 9) The Code Authority Having Jurisdiction (AHJ) must evaluate and provide approval of final installation where variations to these instructions are necessary.

## Installation - Failure to follow these instructions will void all warranties.

These instructions apply to 1½ hour rated fire dampers mounted (blades must be horizontal) in: 1) masonry, block or stud walls and 2) concrete floors or ceilings. Specific requirements in these instructions are mandatory. Dampers must be installed in accordance with these instructions to meet the requirements of UL 555. The installation of the damper and all duct connections to the damper sleeve shall conform to the latest editions of NFPA 90A, Standard for the Installation of Air Conditioning and Ventilating Systems, and the SMACNA Fire, Smoke and Radiation Damper Installation Guide, and UL Classifications R13317.

### 1. CLEARANCES REQUIRED BETWEEN FIRE DAMPER SLEEVES AND WALL/FLOOR OPENINGS

Fire damper assemblies expand during periods of intense heat. Therefore, it is essential that openings in walls or floors be larger than the fire damper assembly to allow for this expansion. The wall/floor opening must be a minimum of 7/8 in. (22mm) larger than the outside diameter of the damper. Refer to Section 4 for additional installation considerations.

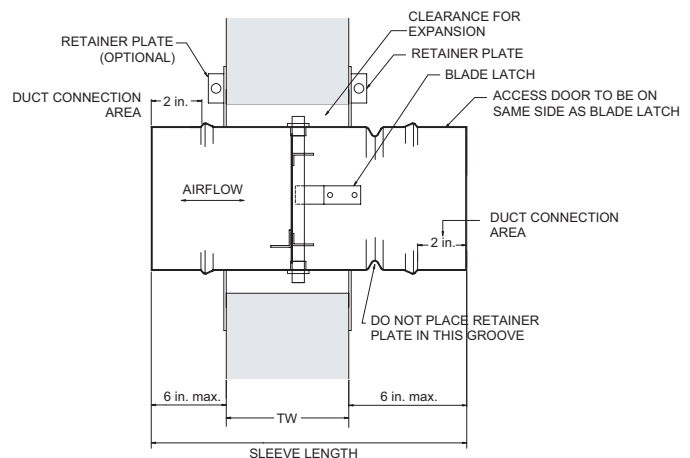

Fig. 1

# Installation - Continued

## 2. SLEEVE LENGTH AND WALL/FLOOR THICKNESS

Insert the damper assembly into the prepared opening, to appropriate depth (see page 2, Fig. 1).

Recommended maximum and minimum insertion depth can be exceeded as long as the  $\text{C}$  of the damper blade remains within the plane of the wall/floor.

**IMPORTANT SAFETY DANGER!** To avoid causing death or serious bodily harm to building occupants, do not insert screws into the damper frame unless used for duct connection within 2 in. (51mm) of the frame end.

The sleeve may extend a maximum of 6 in. (152mm) beyond both sides of the wall or floor. Recommended standard sleeve lengths for various wall/floor thicknesses are:

Wall/Floor Thickness Dimension ( $T_w$ ) Inches (mm)	Sleeve Length Dimension (L) Inches (mm)
Up to 6½ (165)	13 5/8 (346)
6½ - 8½ (165 - 216)	15 5/8 (397)
8½ - 10½ (216 - 267)	17 5/8 (448)

## 3. DUCT TO SLEEVE CONNECTIONS

Dampers are supplied with sleeves from the factory and can be installed without the need for additional field installed sleeves.

Gauge of factory furnished sleeve determines the type of duct to sleeve connections required (see table below). Any duct connection other than the breakaway connections are considered rigid.

Sleeve Gauge (mm)	Duct Dimension Maximum Inches (mm)	Type of Duct to Sleeve Connection Permitted
10 ga. (3.5)	24 (610)	Rigid or Breakaway
14 ga. (2)		
16 ga. (1.5)		
20 ga. (1mm)	24 (610)	Breakaway only
Sleeve thickness must not be less than the gauge of the connecting duct.		
UL Standard 555 requires all ducts to terminate at fire damper sleeves.		

## 4. SECURING THE DAMPER/SLEEVE ASSEMBLY TO WALL AND FLOOR OPENINGS

Damper assemblies must be installed in wall/floor openings using a single retaining plate on either side of the wall/floor or by using a retaining plate on both sides of the wall/floor. The use of a second retaining plate is allowed, but is not necessary. A single retaining plate is provided with the dampers. A second retaining plate can be ordered as an option.

- The retaining plate(s) will open up for easy installation when the clamping screw is loosened. If necessary, remove the clamping screw and nut (see Fig. 2).

*(IMPORTANT: The clamping mechanism should face away from the wall/floor).* Retainer plate(s) are designed to mount flush to the wall/floor and hold the damper in the wall/floor opening.

- Place the damper and attached retainer plate into the wall/floor opening.
- If a second retaining plate is being used, secure it on the opposite side of the wall/floor

## DO NOT POSITION RETAINER PLATE(S) IN FRAME GROOVE

- Verify position, blade orientation, and actuator clearance then tighten the retainer plate clamping screws. The retainer plate(s) must overlap the wall/floor opening a minimum of 1 inch (25mm). Secure the retainer plate(s) to the wall using appropriate fasteners (minimum #8 sheet metal screws) at the four corners of each retainer plate when two retainer plates are used and also within ¾ in. (19mm) of the center of each plate when one retainer plate is used.

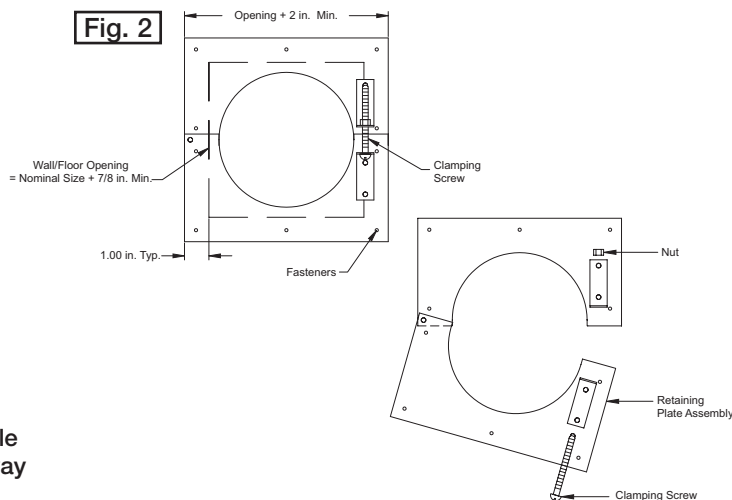

## 5. Recommended Preparation of Openings in Wood and Metal Stud Walls

- Frame wall openings as shown below. (see Fig. 3)
- Double vertical studs are not required for openings 36 in. x 36 in. (914mm x 914mm) or smaller.
- Gypsum wall board must be fastened 12 in. (305mm) on center to all stud and runner flanges surrounding opening. (see Fig. 4)
- All construction and fasteners must meet the requirements of the appropriate wall design (See UL Fire Resistance Directory) and/or local codes.

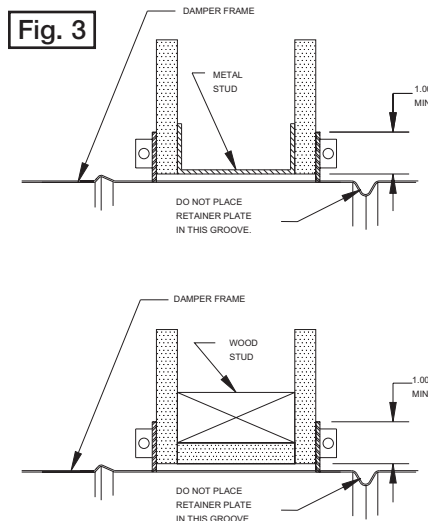

## 6. Round Duct Connections

Round duct connections shall be attached with #8 sheet metal screws as follows:

- Ducts 22 in. (559mm) dia. and smaller shall have three screws.
- Ducts larger than 22 in. (559mm) dia. and up to including 24 in. dia. shall have five screws.

**NOTE:** All breakaway connections described may have duct sealant, PA2084T Duct Sealant Adhesive manufactured by Precision or DP1010 Water Base Duct Sealant manufactured by Design Polymetrics, Grey Pookie or Ductmate PROseal® applied in accordance with SMACNA recommendations.

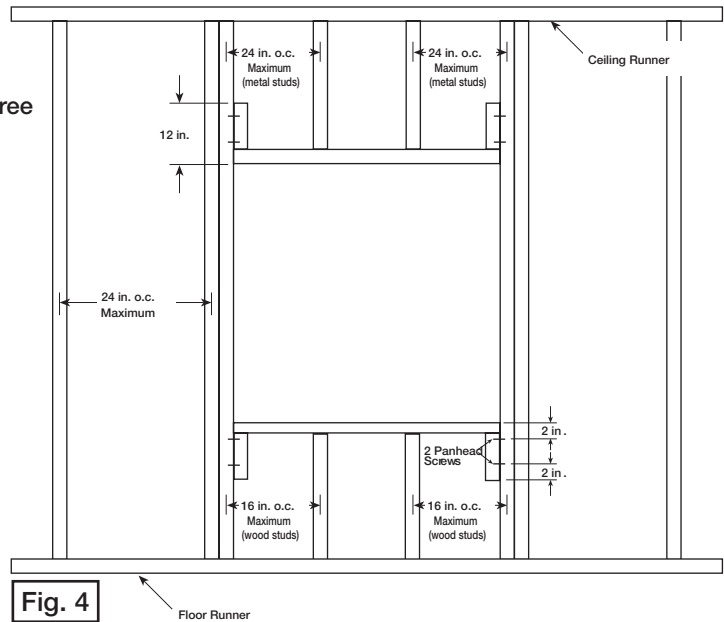
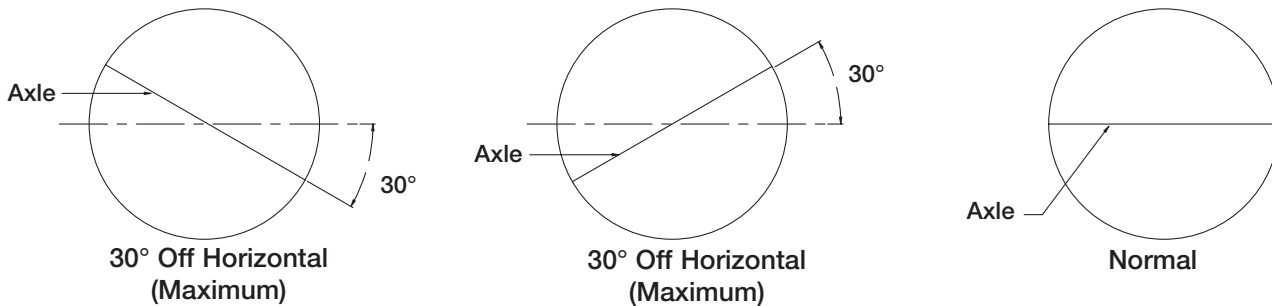

Fig. 4

## DFDR-XXX Blade Orientation



## Damper Maintenance

Dampers do not typically require maintenance as long as they are kept dry and clean. If cleaning is necessary, use mild detergents or solvents. If lubrication is desired for components such as axle bearings, do not use oil-based lubricants or any other lubricants that attract contaminants such as dust.

Dampers must be maintained, cycled, and tested at intervals not less than every six months and in accordance with the latest editions of NFPA 90A & 92A, UL864 and local codes.

## Damper Troubleshooting

The following is a possible cause and correction list for common concerns with the dampers.

Symptom	Possible Cause	Corrective Action
Damper does not fully open and/or fully close	Frame is out of round causing blades to interfere with frame	Adjust frame such that it is round
	Screws interfere with blade	Locate screws and remove
	Contaminants on damper	Clean with a non-oil based solvent (see Damper Maintenance)
Link separated	Heat	Replace link



Copyright © 2008 Greenheck Fan Corporation  
462721 DFDR-XXX FS Rev. 5 December 2008