



Part Number 461868

FSDR-XXX, SEFSDR-XXX, AND SSFSDR-XXX MODELS

1 1/2 Hour Fire & Combination Fire
Smoke Dampers

Vertical and Horizontal Mount

Installation, Operation and Maintenance Instructions

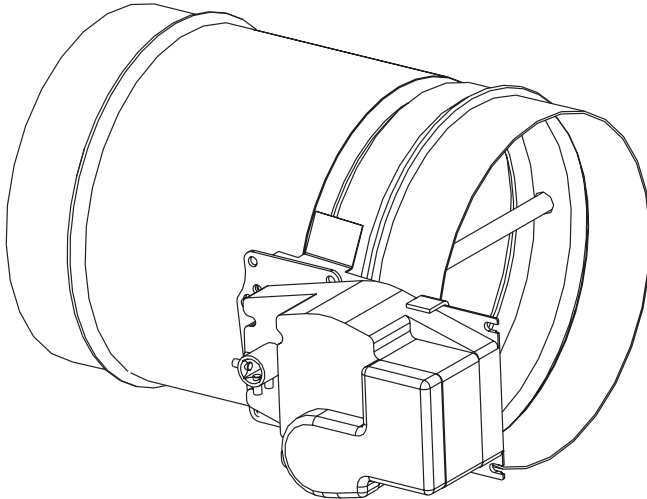

FSDR-XXX, SEFSDR-XXX, and SSFSDR-XXX Model Dampers are intended for installation in accordance with combination fire smoke damper requirements established by:

National Fire Protection Association

NFPA Standards 80, 90A, 92A, 92B, 101, & 105

IBC International Building Codes

New York City (MEA listing #260-91-M)

“UL CLASSIFIED (see complete marking on product)”
“UL CLASSIFIED to Canadian safety standards (see complete marking on product)”

UL Standard 555 & 555S (Classification #R13317)

INSTALLATION SUPPLEMENTS

Refer to the appropriate Greenheck installation supplements for special requirements:

- Steel Deck Supplement



RECEIVING AND HANDLING

Upon receiving dampers, check for both obvious and hidden damage. If damage is found, record all necessary information on the bill of lading and file a claim with the final carrier. Check to be sure that all parts of the shipment, including accessories, are accounted for.

Dampers must be kept dry and clean. Indoor storage and protection from dirt, dust and the weather is highly recommended. Do not store at temperatures in excess of 100°F (38°C).

WARRANTY

Greenheck warrants this equipment to be free from defects in material and workmanship for a period of one year from the shipment date. Any units or parts which prove to be defective during the warranty period will be repaired or replaced at our option. Greenheck shall not be liable for damages resulting from misapplication or misuse of its products. Greenheck will not be responsible for any installation or removal costs. Greenheck will not be responsible for any service work or backcharges without prior written authorization.

ELECTRICAL GUIDELINES

All wiring shall be done in accordance with the National Electrical Code ANSI/NFPA-70 latest edition, any local codes that may apply, and wiring diagrams developed in compliance with the job or project design and specifications.

SAFETY WARNING

Improper installation, adjustment, alteration, service or maintenance can cause property damage, injury or death. Read the installation, operating, and maintenance instructions thoroughly before installing or servicing this equipment. To avoid causing death or serious bodily harm to building occupants, follow all instructions carefully. Dampers must close completely to preserve the integrity of the fire smoke separation.

SAFETY CAUTION!

Electrical input may be needed for this equipment. This work should be performed by a qualified electrician. Verify power before wiring actuator. Greenheck is not responsible for any damage to, or failure of the unit caused by incorrect field wiring.

Due to continuing research, Greenheck reserves the right to change specifications without notice.

This manual is the property of the owner, and is required for future maintenance. Please leave it with the owner when the job is complete.

Table of Contents

Pre-Installation Guideline.....	2
Installation	3-6
• Clearances Required Between Fire Damper Sleeves and Wall/Floor Openings	3
• Sleeve Length and Wall Thickness.....	3
• Round Duct Connections.....	3
• Securing the Damper Assembly to Wall and Floor Openings	4
• Actuator Connections	4
• Connection and Operation of Temperature Control Devices.....	4-5
• FSDR-XXX and DFDR-XXX Blade Orientation.....	5
• Recommended Preparation of Openings in Wood and Metal Stud.....	6
Maintenance	6
Troubleshooting.....	6

Pre-Installation Guidelines

The basic intent of a proper installation is to secure the fire smoke or fire damper in the opening in such a manner as to prevent distortion and disruption of damper operation. This is accomplished by allowing the fire or fire smoke damper in rated separation openings to expand and for the connecting duct to separate in the event of the collapse of the hanging system. The following items will aid in completing the damper installation in a timely and effective manner.

- 1) Check the schedules for proper damper locations within the building. Visually inspect the damper for damage and verify that the fusible link is in place or has not separated. If fusible link is not present or has separated, replace link. Never install a fire damper without the proper UL approved fusible link in place. (Fusible link is standard control option. An electric link may have been provided. Electric links have a button for resetting.)
- 2) Lift or handle damper using the frame. Do not lift damper using blades or actuators.
- 3) Do not install screws into the main body area of the damper frame as screws may interfere with and prevent damper blade from opening and/or closing.
- 4) Damper has label indicating position of damper assembly in the wall. Install accordingly to comply with manufacturer's appropriate UL Classification file number.
- 5) Damper must be installed into duct or opening free of distortion or other misalignment. Damper must not be squeezed or stretched into duct or opening. Out of round, racked, twisted or misaligned installations can cause excessive leakage and/or torque requirements to exceed damper/actuator design.
- 6) Damper and actuator must be kept clean and protected from dirt, dust and other foreign materials prior to and after installation. Examples of such foreign materials include but are not limited to:
 - a) Mortar dust
 - b) Drywall dust
 - c) Firesafing materials
 - d) Wall texture
 - e) Paint overspray
- 7) Damper should be sufficiently covered as to prevent overspray if wall texturing or spray painting will be performed within 5 feet of the damper. Excessive dirt or foreign material deposits on damper can cause excessive leakage and/or torque requirements to exceed damper/actuator design.
- 8) Caulking is not necessary, nor is it allowed, between the damper sleeve and the wall or floor opening (annular space). However, caulking may be applied to the retaining plates.
- 9) ACCESS: Suitable access (such that fusible links, RRL's, actuators, and linkages can be maintained) must be provided for damper inspection and servicing. Where it is not possible to achieve sufficient size access, it will be necessary to install a removable section of duct. (Refer to NFPA 90A).
- 10) The Code Authority Having Jurisdiction (AHJ) must evaluate and provide approval of final installation where variations to these instructions are necessary.

Installation - Failure to follow these instructions will void all warranties.

These instructions apply to 1½ hour rated combination fire smoke and fire dampers mounted in: 1) masonry, block or stud walls and 2) concrete floors or ceilings. Specific requirements in these instructions are mandatory. Dampers must be installed in accordance with these instructions to meet the requirements of UL 555 and UL 555S. The installation of the damper and all duct connections to the damper sleeve shall conform to the latest editions of NFPA 90A, Standard for the Installation of Air Conditioning and Ventilating Systems, and the SMACNA Fire, Smoke and Radiation Damper Installation Guide, and UL Classifications R13317.

1. CLEARANCES REQUIRED BETWEEN FIRE DAMPER SLEEVES AND WALL/FLOOR OPENINGS

Fire damper assemblies expand during periods of intense heat. Therefore, it is essential that openings in walls or floors be larger than the fire damper assembly to allow for this expansion. The wall/floor opening must be a minimum of 7/8 in. (22mm) larger than the outside diameter of the damper. Refer to Section 4 for additional installation considerations.

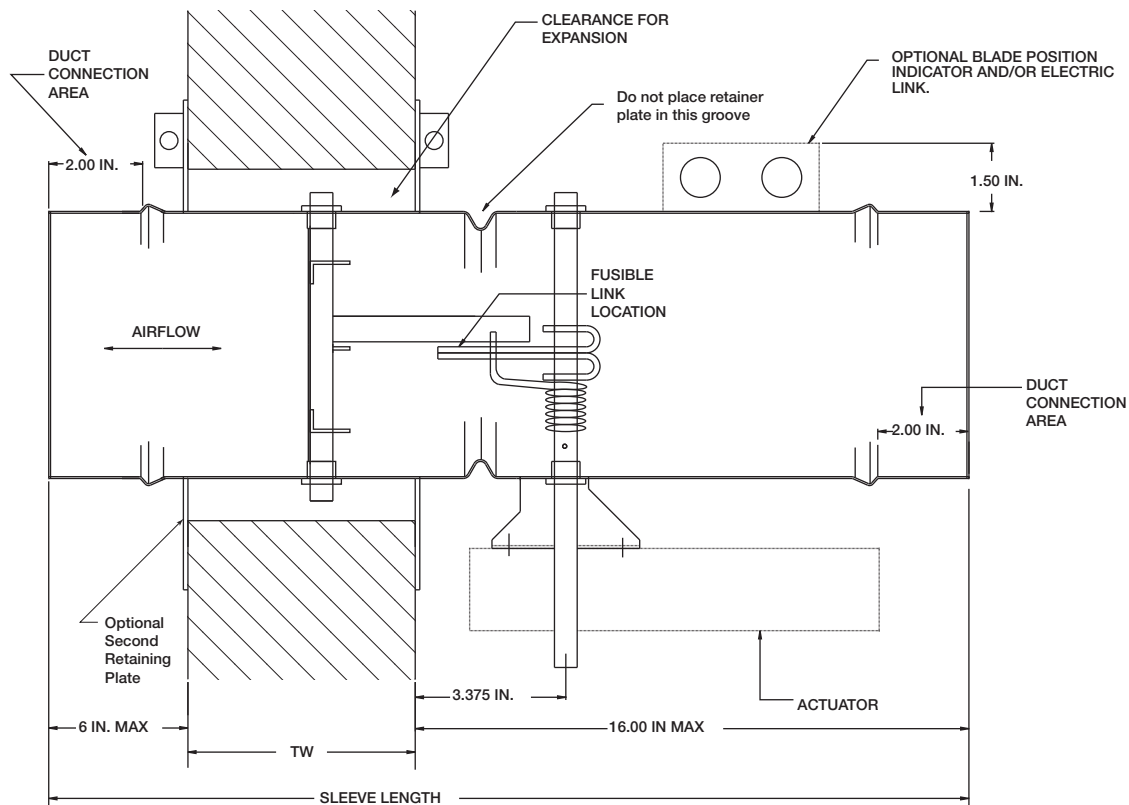

Fig. 1

2. SLEEVE LENGTH AND WALL/FLOOR THICKNESS

Insert the damper assembly into the prepared opening, to appropriate depth (see Fig. 1).

Recommended maximum and minimum insertion depth can be exceeded if:

- 1) the operation of the damper actuator is not impeded and
- 2) the Q_c of the damper blade remains within the plane of the wall/floor

IMPORTANT SAFETY DANGER! : To avoid causing death or serious bodily harm to building occupants, do not insert screws into the damper frame unless used for duct connection within 2 in. (51mm) of the frame end.

The sleeve may extend a maximum of 16 in. (406mm) beyond the wall or floor on the actuator side of the damper and a maximum of 6 in. (152mm) on the opposite side.

3. ROUND DUCT CONNECTIONS

Round duct connections to shall be attached with #8 or #10 sheet metal screws as follows:

- Ducts 22 in. (558mm) dia. and smaller shall have three screws.
- Ducts larger than 22 in. (558mm) dia. up to and including 24 in. (610mm) dia. shall have five screws.

NOTE: All connections described may have duct sealant, PA2084T duct sealant adhesive manufactured by Precision, DP1010 water base duct sealant manufactured by Design Polymetrics, Grey Pookie or Ductmate PROseal[®] applied in accordance with SMACNA recommendations

4. SECURING THE DAMPER/SLEEVE ASSEMBLY TO WALL AND FLOOR OPENINGS

Damper assemblies must be installed in wall/floor openings using a single retaining plate on either side of the wall/floor or by using a retaining plate on both sides of the wall/floor. The use of a second retaining plate is allowed, but is not necessary. A single retaining plate is provided with the dampers. A second retaining plate can be ordered as an option. The outside dimension of the supplied retainer plate is nominal dia. + 4½ inches (114mm).

- The retaining plate(s) will open up for easy installation when the clamping screw is loosened. If necessary, remove the clamping screw and nut (see **Fig. 2**).
- Position the retaining plate between the blade axle and the actuator shaft as shown in **Figure 1**. Do not place the retaining plate in the groove. **IMPORTANT:** The clamping mechanism should face away from the wall/floor.
- Place the damper and attached retainer plate into the wall/floor opening.
- If a second retaining plate is being used, secure it on the opposite side of the wall/floor.
- Verify position, blade orientation, and actuator clearance then tighten the retainer plate clamping screws.
- The retainer plate(s) must overlap the wall/floor opening a minimum of 1 inch (25mm).
- Secure the retainer plate(s) to the wall at the four corners of each plate when two retainer plates are used and also within ¼ in. (19mm) of the center of each side when one retainer plate is used. The following fasteners shall be used:
 - #8 or #10 screws of a length such that the screw engages the steel stud/track by ½ in. (13mm) (steel framing)
 - #8 or #10 screws of a length such that screw engages the wood stud by 1¾ in. (44mm) (wood framing)
 - Steel anchors or self tapping concrete screws penetrating masonry or block 1¼ in. (32mm).

5. ACTUATOR CONNECTIONS

Electrical and/or pneumatic connections to damper actuators should be made in accordance with wiring and piping diagrams developed in compliance with applicable codes, ordinances and regulations (see **Electrical Guidelines**).

6. CONNECTION AND OPERATION OF TEMPERATURE RESPONSE DEVICES (Fusible Link, RRL OPTION, OCI OPTION, TOR OPTION, and PRV OPTION)

RRL - Dampers will be supplied with a fusible link temperature response device, as a standard. An optional thermostat type temperature response device may have been installed. The device is a RRL (resettable link device), which only incorporates one thermostat and therefore the damper remains closed as soon as its sensor temperature is reached. The RRL does not contain blade indication switches. Refer to **Fig. 4**.

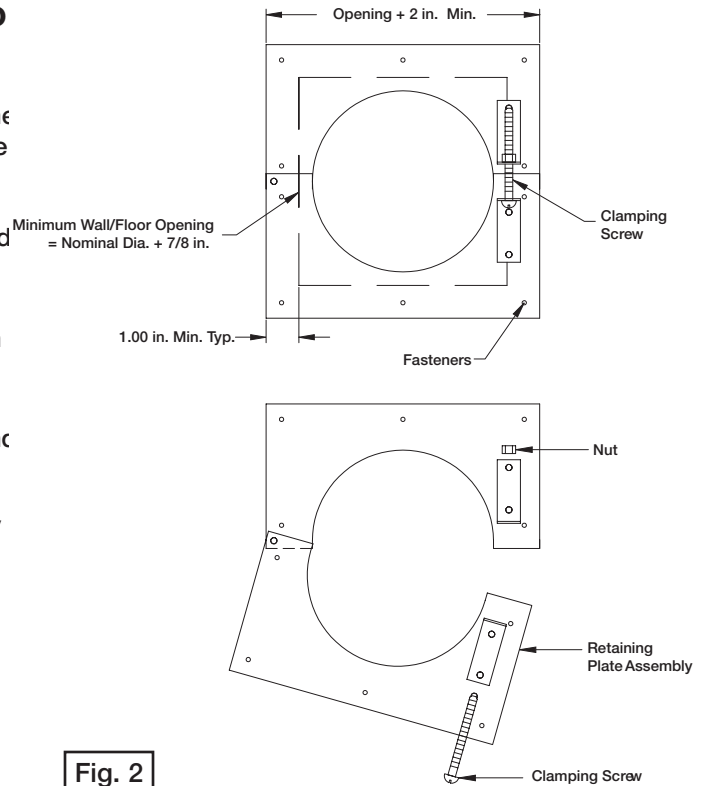

Fig. 2

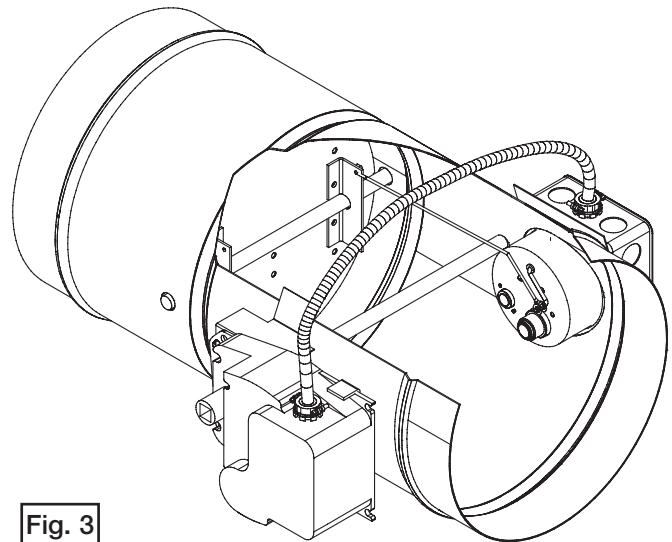

Fig. 3

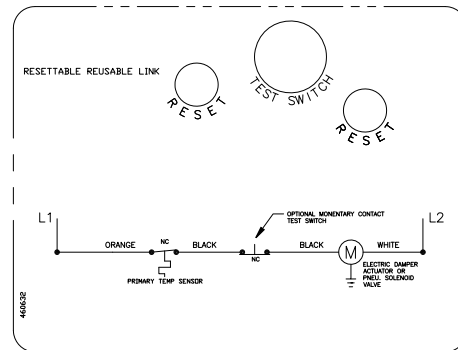

Fig. 4 RRL Wiring

6.CONNECTION AND OPERATION OF TEMPERATURE RESPONSE DEVICES (Fusible Link, RRL OPTION, OCI OPTION, TOR OPTION, and PRV OPTION) continued....

OCI - The OCI (open or closed indicator) option contains a single pole, double throw switch used to indicate the damper blade position. The switch provides a positive open or closed signal when used in conjunction with remote indicator lights. Refer to **Fig. 5 & 6**

TOR - The TOR (temperature override device) option incorporates two thermostats with fixed settings (usually 165°F [74°C] and 350°F [177°C]). The primary sensor (the sensor with the lower temperature setting) can be bypassed by an external electrical signal allowing the damper to reopen until the temperature reaches the setting of the secondary sensor (the sensor with the higher temperature setting). When the temperature of the secondary sensor is exceeded the damper closes and remains closed thereafter (**Fig. 7**)

The TOR assembly also contains a single pole, double throw switch used to indicate damper blade position. The switch provides a positive open or closed signal when used in conjunction with remote indicator lights. See **Fig. 6** for wiring of the TOR thermostats and indicator switches.

If either the TOR or the RRL is ordered with a pneumatic actuator, an EP switch is required with an appropriate electric power circuit to allow the electric thermostat to control the pneumatic actuator.

PRV - The PRV (pneumatic relief valve) option is heat responsive device used with pneumatic actuators. This can be used in place of EP switch where a RRL is used. The PRV activates when temperature in excess of the temperature of the fusible link are detected. When the fusible link melts, air from the actuator is exhausted to close the dampers. Pneumatic actuators are to be piped per local code.

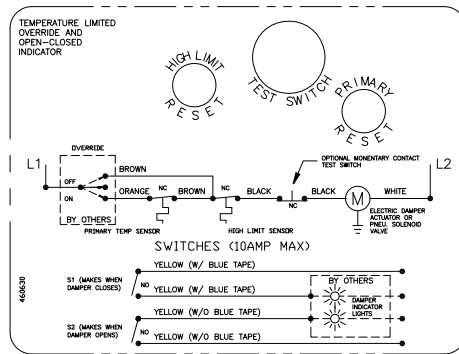

Fig. 7 TOR Wiring

RATINGS (Fig. 4, 5, 6 & 7)

- Integral Switch Type:** Single Pole, double throw
- Electrical Capacity:** 10 Amps, 1/3 hp, 120 or 240 Vac
- 1/2 Amp, 125 Vdc;
- 1/4 Amp 250 Vdc
- 5 Amps, 120 Vac "L" (lamp load)
- 1.0 Amps, 24 Vac
- 1.5 Amps, 24 Vdc
- Temperature Limit:** 165° F (standard primary sensor)
- 212° F (optional primary sensor)
- 250° F (secondary sensor)*
- 350° F (secondary sensor)*
- * based on actuator temperature rating

FSDR-XXX and DFDR-XXX Blade Orientation

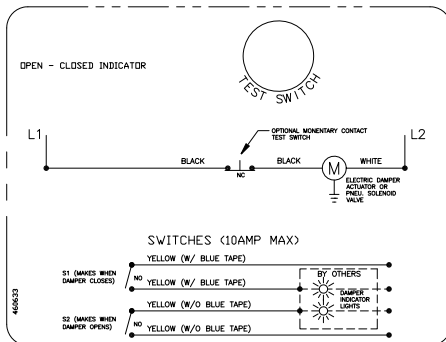
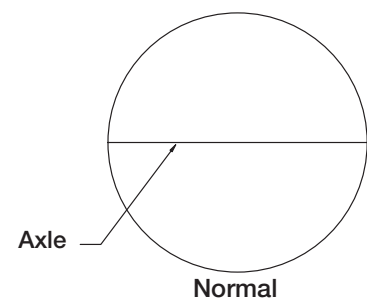
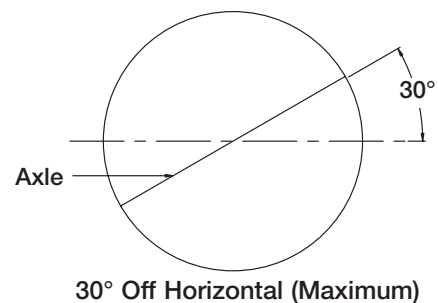
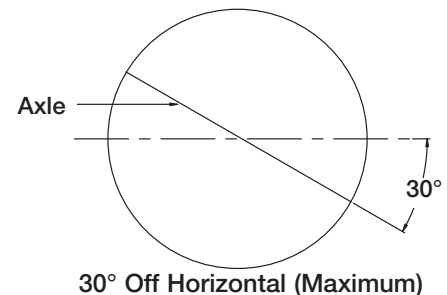

Fig. 5 OCI Wiring

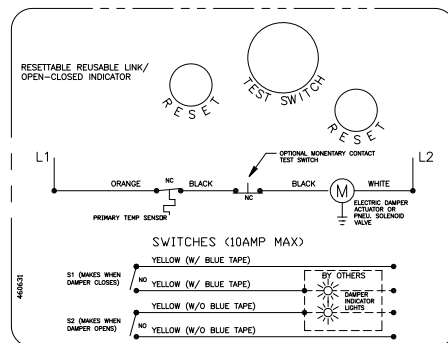
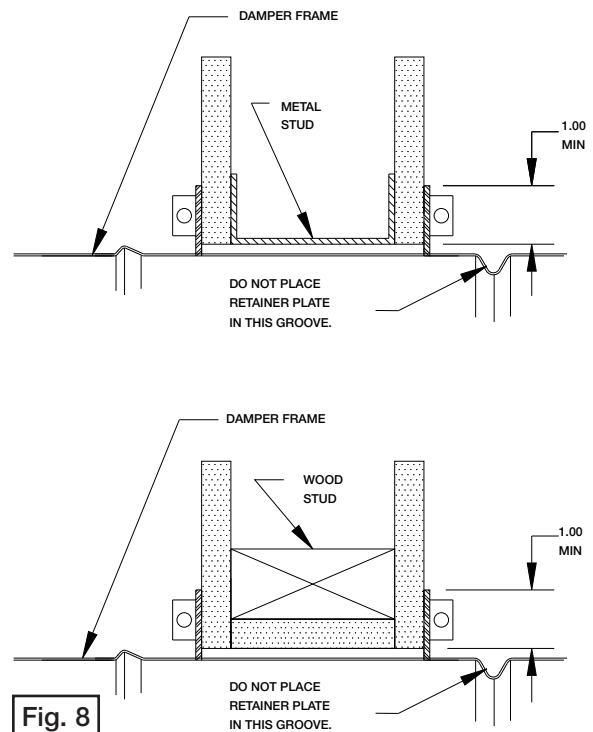
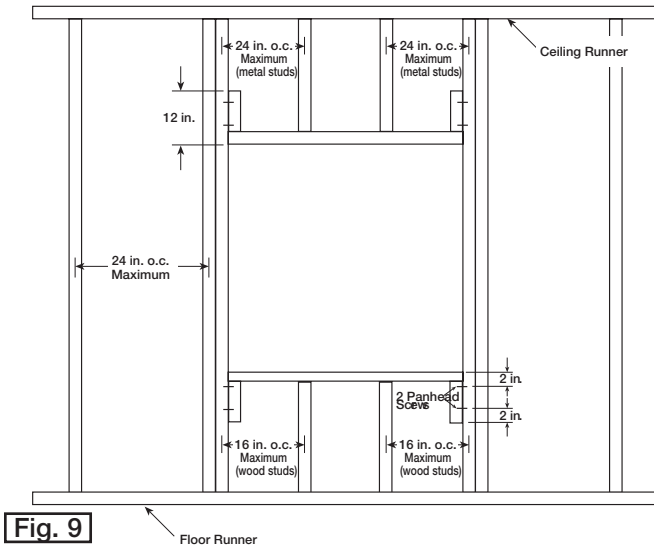

Fig. 6 RRL/OCI Wiring

8. Recommended Preparation of Openings in Wood and Metal Stud Walls

- Frame wall openings as shown. (see Fig. 8)
- Double vertical studs are not required for openings 36 in. x 36 in. (914mm x 914mm) or smaller.
- Gypsum wall board must be fastened 12 in. (305mm) on center to all stud and runner flanges surrounding opening. (see Fig. 9)
- All construction and fasteners must meet the requirements of the appropriate wall design (See UL Fire Resistance Directory) and/or local codes.



Damper Maintenance

Dampers do not typically require maintenance as long as they are kept dry and clean. If cleaning is necessary, use mild detergents or solvents. If lubrication is desired for components such as axle bearings, jackshaft bearings and jamb seals, do not use oil-based lubricants or any other lubricants that attract contaminants such as dust.

Dampers and their actuator(s) must be maintained, cycled, and tested a minimum in accordance with:

- The latest editions of NFPA 80, 90A, 92A, 92B, 101, 105, UL864, AMCA 503-03 and local codes.
- Actuator manufacturer recommendations.

Damper Troubleshooting

The following is a possible cause and correction list for common concerns with the dampers.

Symptom	Possible Cause	Corrective Action
Damper does not fully open and/or close	Frame is 'racked' causing blades to bind on jamb seals	Adjust frame such that it is square and plumb
	Actuator linkage loose	Close damper, disconnect power, adjust and tighten linkage
	Defective motor	Replace
	Screws in damper linkage	Damper installed too far into wall. Move out to line as designated on damper label
	Contaminants on damper	Clean with a non-oil based solvent (see Damper Maintenance)
RRL or TOR sensor tripped	Heat	Push reset button located on backside of RRL or TOR
Damper does not operate	No power supplied to the actuator	Add power supply



Copyright © 2010 Greenheck Fan Corporation
461868 FSDR-XXX Rev. 11 March 2010