

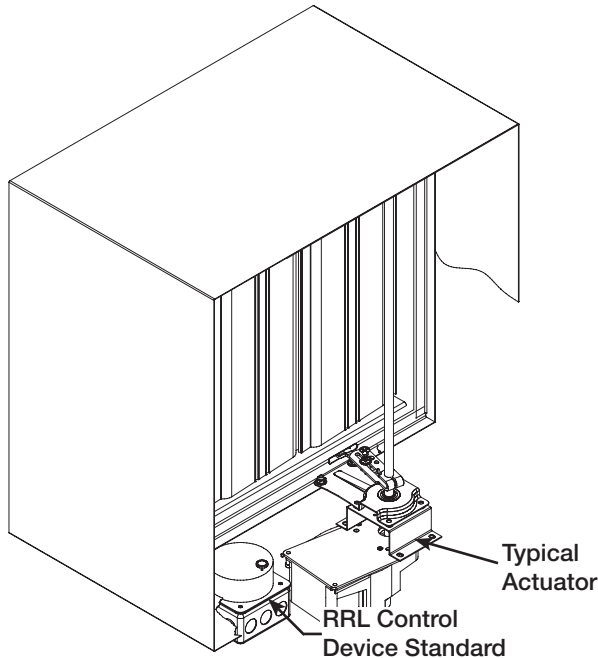

## Combination Fire Smoke Dampers (with factory installed sleeve and actuator) Vertical Blade

### Installation, Operation and Maintenance Instructions



FSD-3XXV Series Dampers are intended for installation in accordance with combination fire smoke damper requirements established by:

**National Fire Protection Association**

NFPA Standards 80, 90A, 92A, 92B, 101, & 105

**IBC International Building Codes**

**New York City** (MEA listing #260-91-M)

**California State Fire Marshal**

Listing #3225-0981:103 and 3230-0981:104

**“UL CLASSIFIED (see complete marking on product)”**

**“UL CLASSIFIED to Canadian safety standards (see complete marking on product)”**

UL Standard 555 & 555S (Classification R13317)

#### Installation Supplements

Refer to the appropriate Greenheck installation supplements for special requirements:

- Concrete Floor with Steel Deck
- Drive Slip Breakaway Connection
- Field Installed Sleeve
- Fire Resistant Ventilated Duct Assembly
- Firestop Material
- Greenheck Test Switch
- Grille Installation
- Metal Stud in Shaftwall
- No Flow Smoke Detector
- Open or Close Indicator
- Quick Connect Breakaway Connections
- Resettable Link
- Sealant Supplement
- Single Side Retaining Angle
- Single 3-Sided Retaining Angle
- Sleeve Extension
- Smoke Detector
- Tunnel Corridor

#### Safety Warning:

Improper installation, adjustment, alteration, service or maintenance can cause property damage, injury or death. Read the installation, operating, and maintenance instructions thoroughly before installing or servicing this equipment.

#### Receiving and Handling

Upon receiving dampers, check for both obvious and hidden damage. If damage is found, record all necessary information on the bill of lading and file a claim with the final carrier. Check to be sure that all parts of the shipment, including accessories, are accounted for.

Dampers must be kept dry and clean. Indoor storage and protection from dirt, dust and the weather is highly recommended. Do not store at temperatures in excess of 100°F (38°C).

#### Warranty

Greenheck warrants this equipment to be free from defects in material and workmanship for a period of one year from the purchase date. Any units or parts which prove to be defective during the warranty period will be repaired or replaced at our option. Greenheck shall not be liable for damages resulting from misapplication or misuse of its products. Greenheck will not be responsible for any installation or removal costs. Greenheck will not be responsible for any service work or backcharges without prior written authorization.

Due to continuing research, Greenheck reserves the right to change specifications without notice.

This manual is the property of the owner, and is required for future maintenance. Please leave it with the owner when the job is complete.

## Table of Contents

Pre-Installation Guidelines.....	2
Electrical Guidelines.....	2
Installation .....	3-7
• Clearances Required Between Fire Damper Sleeves and Wall/Floor Openings .....	3
• Sleeve Length and Wall Thickness .....	3
• Duct to Sleeve Connections.....	4
• Securing the Damper/Sleeve Assembly to Wall and Floor Openings .....	4
• Actuator Connections.....	5
• Connection and Operation of Temperature Control Devices .....	5
• Recommended Preparation of Openings in Wood and Metal Stud Walls .....	6
• Breakaway Connections .....	7-8
Maintenance .....	7
Troubleshooting.....	7

## Pre-Installation Guidelines

The basic intent of a proper installation is to secure the fire or fire smoke damper in, not to, the opening in such a manner as to prevent distortion and disruption of damper operation. This is accomplished by allowing the fire or fire smoke damper in rated separation openings to expand and for the connecting duct to separate in the event of the collapse of the hanging system. The following items will aid in completing the damper installation in a timely and effective manner.

- 1) Check the schedules for proper damper locations within the building. Visually inspect the damper for damage and verify that the Reusable Resettable Link (RRL) is in place or has not activated. Never install a fire damper without the proper UL approved RRL in place. (RRL is standard control option. These electric links have a button for resetting.) If damper is furnished with fusible link, visually inspect the link to verify its not missing or broken. Replace link as necessary.
- 2) Lift or handle damper using sleeve or frame. Do not lift damper using blades or actuators.
- 3) Damper has label on outside of sleeve indicating a 'No Screw' area. Do not install screws into this area as screws may interfere with unexposed blade linkage and prevent damper blades from opening and/or closing.
- 4) Damper has label indicating position of damper and sleeve assembly in the wall. Install accordingly to comply with manufacturer's appropriate UL Classification file number.
- 5) Damper must be installed into duct or opening square and free of twist or other misalignment. Damper must not be squeezed or stretched into duct or

opening. Out of square, racked, twisted or misaligned installations can cause excessive leakage and/or torque requirements to exceed damper/actuator design.

- 6) Damper and actuator must be kept clean and protected from dirt, dust and other foreign materials prior to and after installation. Examples of such foreign materials include but are not limited to:
  - a) Mortar dust
  - b) Drywall dust
  - c) Firesafing materials
  - d) Wall texture
  - e) Paint overspray
- 7) Damper should be sufficiently covered as to prevent overspray if wall texturing or spray painting will be performed within 5 feet of the damper. Excessive dirt or foreign material deposits on damper can cause excessive leakage and/or torque requirements to exceed damper/actuator design.
- 8) Caulking is not necessary, nor is it allowed, between the damper sleeve and the wall or floor opening (annular space). However, caulking may be applied to the retaining angles.
- 9) ACCESS: Suitable access (such that RRL's and actuators can be maintained, etc.) must be provided for damper inspection and servicing. Where it is not possible to achieve sufficient size access, it will be necessary to install a removable section of duct. (Refer to NFPA 90A).
- 10) The Code Authority Having Jurisdiction (AHJ) must evaluate and provide approval of final installation where variations to these instructions are necessary.

## Electrical Guidelines

### Electrical Guidelines

All wiring shall be done in accordance with the National Electrical Code ANSI/NFPA-70 latest edition, any local codes that may apply, and wiring diagrams developed in compliance with the job or project design and specifications.

### Safety Caution!

Electrical input may be needed for this equipment. This work should be performed by a qualified electrician. Verify power before wiring actuator. Greenheck is not responsible for any damage to, or failure of the unit caused by incorrect field wiring. To avoid causing death or serious bodily harm to building occupants, follow all instructions carefully. Dampers must close completely to preserve the integrity of the fire smoke separation.

# Installation - Failure to follow these instructions will void all warranties.

These instructions apply to 1½ hour rated combination fire smoke dampers mounted (blades must be vertical) in: masonry, block, or stud walls. Specific requirements in these instructions are mandatory. Dampers must be installed in accordance with these instructions to meet the requirements of UL555 and UL555S. The installation of the damper and all duct connections to the damper sleeve shall conform to the latest editions of NFPA90A, Standard for the Installation of Air Conditioning and Ventilating Systems, and the SMACNA Fire, Smoke and Radiation Damper Installation Guide, and UL Classifications R13317.

## 1. CLEARANCES REQUIRED BETWEEN FIRE DAMPER SLEEVES AND WALL/FLOOR OPENINGS

Fire damper and sleeve assemblies expand during periods of intense heat. Therefore, it is essential that openings in walls or floors be larger than the fire damper and sleeve assembly to allow for this expansion. Minimum clearances required between the outside of fire damper sleeve assemblies and wall/floor openings are:

- Galvanized steel fire dampers and sleeves: ⅛ in. (3mm) per foot of damper width and height with a minimum clearance of ¼ in. (6mm), maximum of ½ in. (38mm).

Recommended clearances, for width and/or height dimensions of:

- 36 in. (914mm) or less: ½ in. (13mm) clearance

These are total clearances (ignoring fastener heads) and do not need to be equally spaced around the damper.

## 2. SLEEVE LENGTH AND WALL THICKNESS

Insert the sleeved damper assembly into the prepared opening, to appropriate depth (refer to label on outside of sleeve for location of damper in wall; see Dimension A and Detail 1, Fig. 1).

Recommended maximum and minimum insertion depth can be exceeded if:

- The operation of the damper is not impeded and
- The  $Q_c$  of the damper frame remains within the plane of the wall and
- Attachments made through the retaining angle do not penetrate the 'No Screw' area designated on the damper sleeve.

**IMPORTANT SAFETY DANGER!** : To avoid causing death or serious bodily harm to building occupants, do not penetrate the 'No Screw' area designated on the damper sleeve or the damper may not close properly.

The sleeve may extend a maximum of 16 in. beyond the wall on the actuator side of the damper and a maximum of 6 in. on the opposite side. Recommended standard sleeve lengths for various wall thicknesses are:

Wall Thickness Dimension ( $T_w$ )	Sleeve Length Dimension (L)
4 - 6 in. (102mm - 152mm)	16 in. (406mm)
7 - 10 in. (178mm - 254mm)	21 in. (533mm)
11 - 13 in. (279mm - 330mm)	24 in. (610mm)

Fig. 1

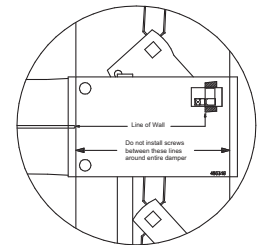
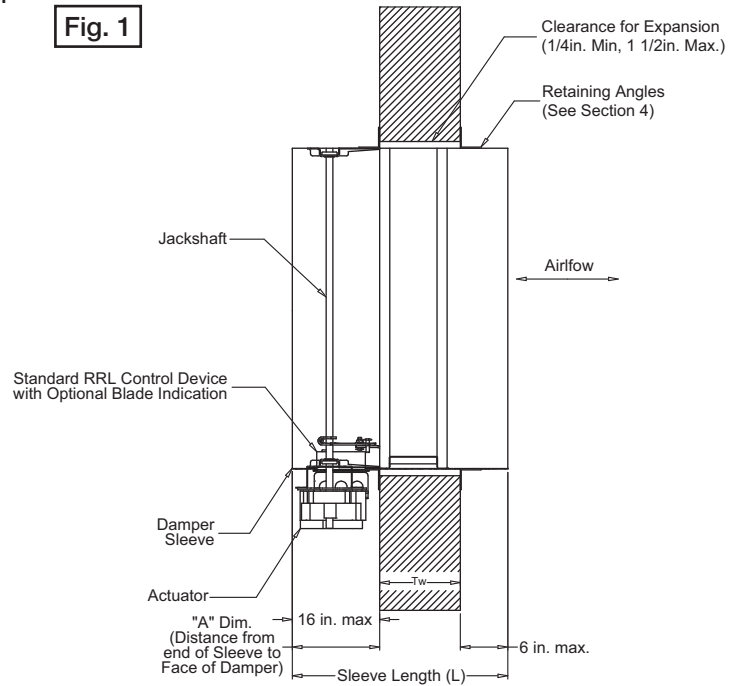

Detail 1  
(Located on Bottom of Damper)

Example: A 12 in. x 12 in. (305mm x 305mm) damper would require a minimum clearance of ¼ in. (6mm.)  
A 36 in. x 12 in. (914mm x 350mm) damper would require a minimum clearance of ½ in. (13mm) on width and ¼ in. (6mm) on height.

### 3. DUCT TO SLEEVE CONNECTIONS

Dampers are supplied with sleeves and actuators from the factory and can be installed without the need for additional field installed sleeves.

Gauge of factory furnished sleeve determines the type of duct to sleeve connections required (see table below). Any duct connection other than those breakaway connections described on page 6 are considered rigid. Factory furnished duct collars, type R and O, are also considered breakaway (see Fig. 2).

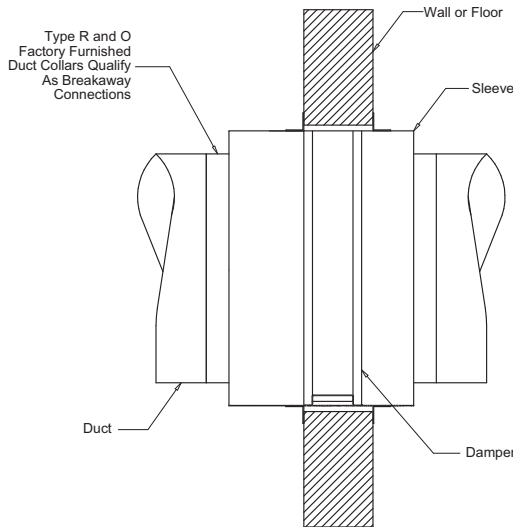

**Fig. 2** Damper with type R or O transition factory furnished.

Sleeve Gauge	Duct Dimension	Type of Duct to Sleeve Connection Permitted
14 ga. (0.075 in.) - 10 ga. (0.138 in.) [2mm - 3.5mm]	All duct sizes	Rigid or Breakaway
16 ga. (0.060 in.) [1.5mm]	36 in. (914mm) max. width 24 in. (610mm) max. width 24 in. (610mm) diameter	Rigid only
16 ga. (0.060 in.) [1.5mm]	All duct sizes	Breakaway only
18 ga. (0.048 in.) [1.2mm]	85 in. (2159mm) wide and over	
20 ga. (0.036 in.) [0.9mm]	55 in. - 84 in. wide (1397mm - 2134mm)	
22 ga. (.030 in.) [0.76mm]	31 in. - 54 in. wide (787mm - 1372mm)	
24 ga. (0.024) [0.6mm]	13 in. - 30 in. wide (330mm - 762mm)	
26 ga. (0.018 in.) [0.46mm]	12 in. wide and under (305mm)	

See page 6 for additional information on breakaway sleeve connections. Sleeve thickness must not be less than the gauge of the connecting duct. UL Standard 555 requires all ducts to terminate at fire damper sleeves.

### 4. SECURING THE DAMPER/SLEEVE ASSEMBLY TO WALL OPENINGS

Damper/sleeve assemblies must be installed in wall openings using retaining angles on at least one side of the wall as described below:

- Retaining angles for 1½ hour rated dampers with a width and height 48 in. (1219mm) or less must be a minimum of 20 ga. (1mm). Retaining angles for all 3 hour rated dampers and all dampers with a width or height greater than 48 in. (1219mm) must be a minimum of 16 gauge (1.5mm). The leg of the retaining angle on the damper sleeve shall be a minimum of 1¼ in. (32mm). The leg of the retaining angle on the wall/floor shall be long enough to cover the annular space and overlap the wall/floor by a minimum of 1 in. (25mm).

- Retaining angle must be attached to the damper using one or more of the following methods of attachment (refer to label on outside of sleeve for 'No Screw' area):

- Tack or spot welds
- #10 (¾ in. max. [19mm]) sheet metal screws
- ¼ in. (6mm) bolts and nuts
- ⅜ in. (5mm) steel pop rivets

A minimum of two connections per side, top, and bottom, 12 in. (305mm) O.C. (on center) maximum for openings of 48 in. W x 32 in. H (1219mm x 812mm) and less, and 6 in. (152mm) O.C. for openings 100 in. W x 32 in. H (2540mm x 32mm) or less. The angles must be attached to all 4 sides of the sleeve with butt joints at each corner. A minimum of two attachments are required on each side, top and bottom. Ensure that attachment device does not interfere with the operation of the damper and the free movement of the damper blades. The angles need not be attached to each other at the corners. Do not secure the retaining angle to the fire separation (see Fig. 3).

- Retaining angles should not be fastened to the wall material. The angles should only sandwich the wall and allow for damper expansion during periods of intense heat.

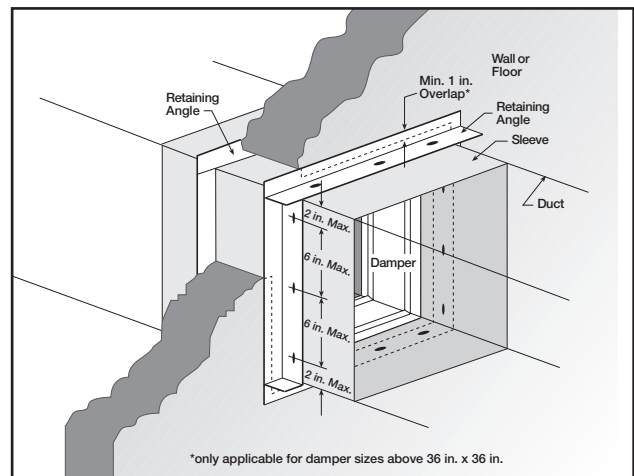

**Fig. 3** Both vertical and horizontal damper installations are typified by these drawings.

Damper Model	Maximum Single Section Size	Maximum Multiple Section Size
FSD-311V	50 x 32	100 x 32

## 5. ACTUATOR CONNECTIONS

Electrical and/or pneumatic connections to damper actuators should be made in accordance with wiring and piping diagrams developed in compliance with applicable codes, ordinances and regulations (see **Electrical Guidelines**).

## 6. CONNECTION AND OPERATION OF TEMPERATURE RESPONSE DEVICES (RRL STANDARD, OCI OPTION, AND TOR OPTION)

**RRL** - Dampers will be supplied with a thermostat-type temperature response device, as a standard. The device is a RRL (resettable link device), which only incorporates one thermostat and therefore the damper remains closed as soon as its sensor temperature is reached. The RRL does not contain blade indication switches. Refer to **Fig. 4** for wiring of the RRL thermostat.

**OCI** - The OCI (open or closed indicator) option contains a single pole, double throw switch used to indicate the damper blade position. The switch provides a positive open or closed signal when used in conjunction with remote indicator lights. Refer to **Fig. 5 & 6** for wiring of the OCI option.

**TOR** - The TOR (temperature override device) option incorporates two thermostats with fixed settings (usually 165°F [74°C] and 350°F [177°]). The primary sensor (the sensor with the lower temperature setting) can be bypassed by an external electrical signal allowing the damper to reopen until the temperature reaches the setting of the secondary sensor (the sensor with the higher temperature setting). When the temperature of the secondary sensor is exceeded the damper closes and remains closed thereafter (**Figure 7**).

The TOR assembly also contains a single pole, double throw switch used to indicate damper blade position. The switch provides a positive open or closed signal when used in conjunction with remote indicator lights. See **Fig. 7** for wiring of the TOR thermostats and indicator switches.

If either the TOR or the RRL is ordered with a pneumatic actuator, an EP switch is required with an appropriate electric power circuit to allow the electric thermostat to control the pneumatic actuator.

**PRV** - The PRV (pneumatic relief valve) option is heat responsive device used with pneumatic actuators. This can be used in place of EP switch where a RRL is used. The PRV activates when temperature in excess of the temperature of the fusible link are detected. When the fusible link melts, air from the actuator is exhausted to close the dampers. Pneumatic actuators are to be piped per local code.

## 7. RECOMMENDED PREPARATION OF OPENINGS IN WOOD AND METAL STUD WALLS

- Frame wall openings as shown. (see **Fig. 8 & 9**)
- Double vertical studs are not required for openings 36 in. x 36 in. (914mm x 914mm) or smaller.
- Gypsum wall board must be fastened 12 in. (350mm) on center to all stud and runner flanges surrounding opening. (see **Fig. 10**)
- All construction and fasteners must meet the requirements of the appropriate wall design (See UL Fire Resistance Directory) and/or local codes.

## RATINGS (Fig. 4, 5, 6 & 7)

**Integral Switch Type:** Single Pole, double throw

**Electrical Capacity:** 10 Amps, 1/3 hp, 120 or 240 Vac

1/2 Amp, 125 Vdc;

1/4 Amp 250 Vdc

5 Amps, 120 Vac "L" (lamp load)

1.0 Amps, 24 Vac

1.5 Amps, 24 Vdc

**Temperature Limit:** 165° F (standard primary sensor)

212° F (optional primary sensor)

250° F (secondary sensor)\*

350° F (secondary sensor)\*

\* based on actuator temperature rating

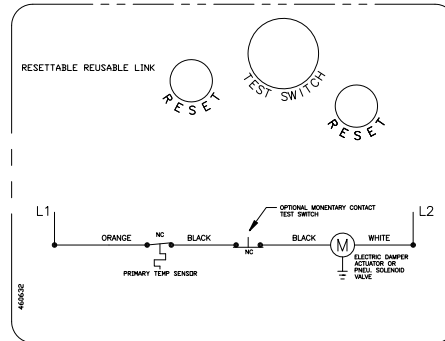

**Fig. 4 RRL Wiring**

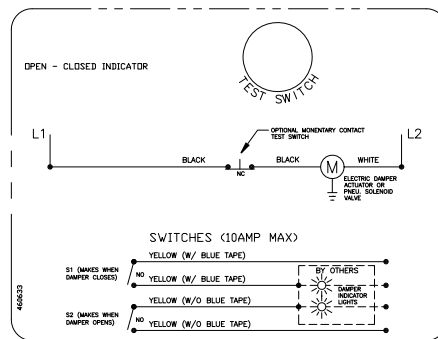

**Fig. 5 OCI Wiring**

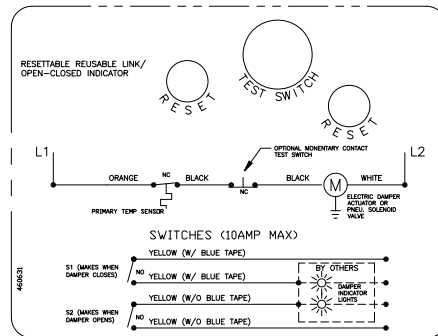

**Fig. 6 RRL/OCI Wiring**

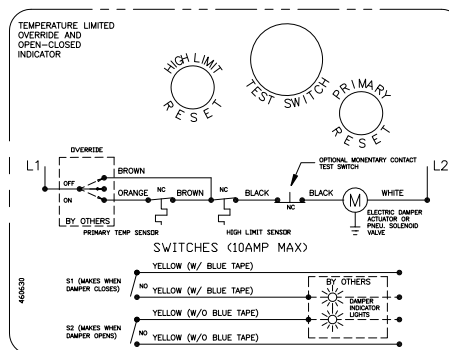

**Fig. 7 TOR Wiring**

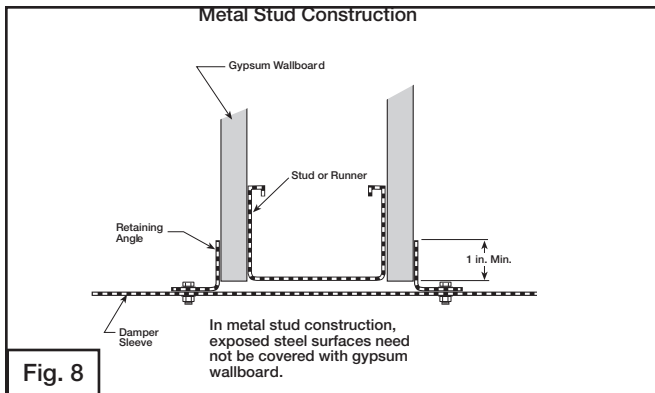

Fig. 8

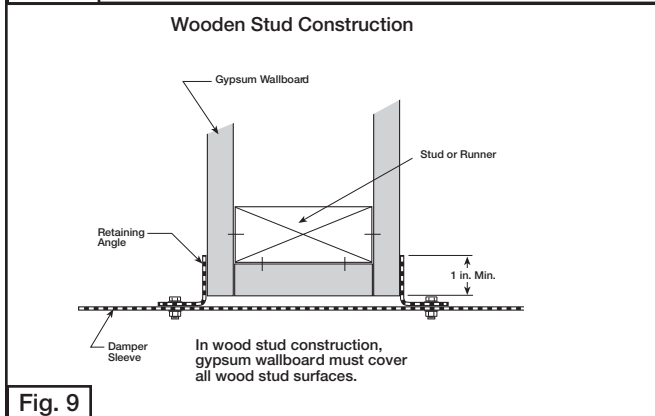

Fig. 9

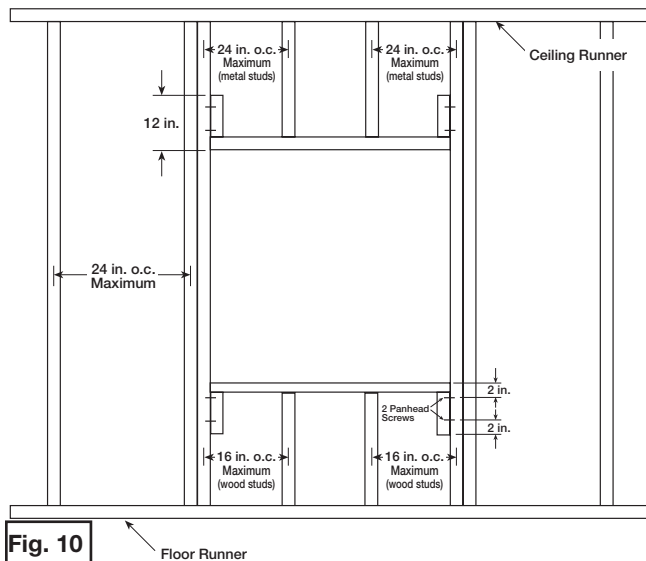

Fig. 10

**8. DUCT-SLEEVE CONNECTIONS**

**Traditional Breakaway Style Transverse Joints**

Transverse joints illustrated at right have always been approved as breakaway connections. SMACNA testing has also approved the following variations as breakaway connections.

- The breakaway connections shown to the right (Fig. 12) can be applied with maximum of two #10 (19mm) sheet metal screws on each side and on the bottom located in the center of the slip pocket and penetrating both sides of the slip pocket.
- Transverse joints illustrated can be applied as top and bottom joints with Drive Slip - side joints in duct heights up to 20 inches (508mm) see Fig. 11.



Fig. 11

**Round and Oval Duct Breakaway Connections**

Round or flat oval ducts connected to Type R or O damper collars shall be attached with #10 (19mm) sheet metal screws as follows:

- Ducts to 22 in. (558mm) wide or diameter and smaller shall have three screws.
- Ducts larger than 22 in. wide (558mm) or diameter up to and including 36 in. (914mm) wide or diameter shall have five screws.

**NOTE:** All breakaway connections described may have duct sealant applied, PA2084T duct sealant adhesive manufactured by Precision, DP1010 water base duct sealant manufactured by Design Polymetrics, Grey Pookie or Ductmate PROseal® in accordance with SMACNA recommendations.

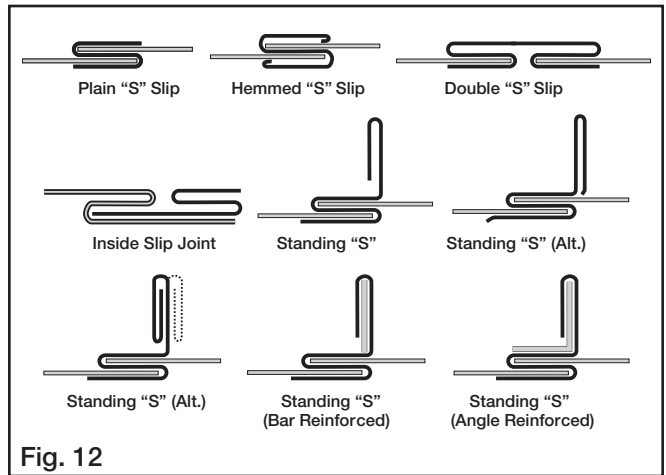

Fig. 12

**Manufactured Flanged System Breakaway Connections (Fig. 13)**

Flanged connection systems manufactured by Ductmate, Ward, and Nexus are approved as breakaway connections when installed as illustrated (Fig. 13).

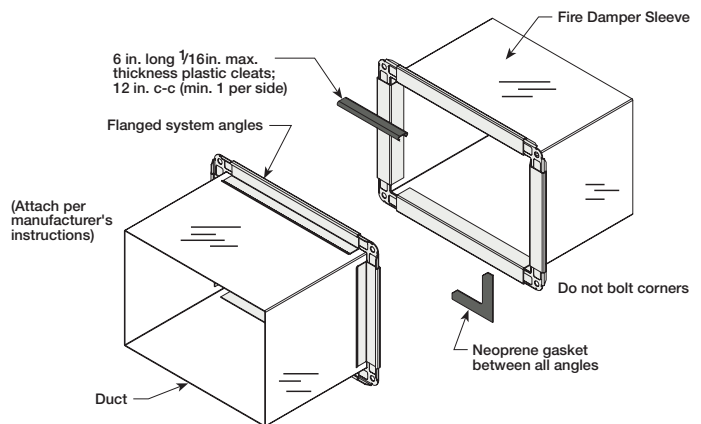

Fig. 13

## Proprietary Flange System Breakaway Connections

(TDC by Lockformer, TDF by Engle)

TDC and TDF systems are approved as breakaway connections when installed as described in the TDC or TDF addendum to the SMACNA Duct Construction. Standard 6 in. (152mm) metal clip may be used with spacing as shown in diagram (Fig. 14 & 15). 3/8 in. (9.5mm) metal bolts and nuts may be used to fasten together corner pieces. (see Fig. 16)

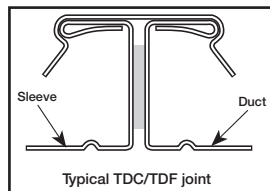

Fig. 14

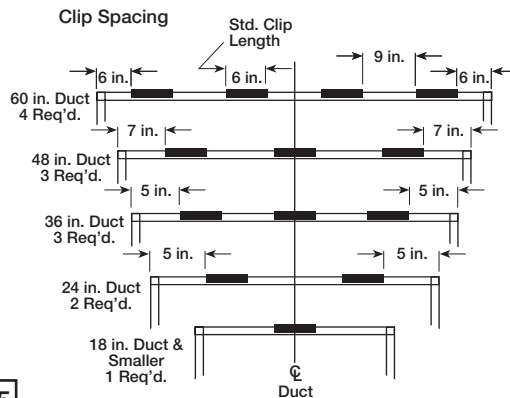

Fig. 15

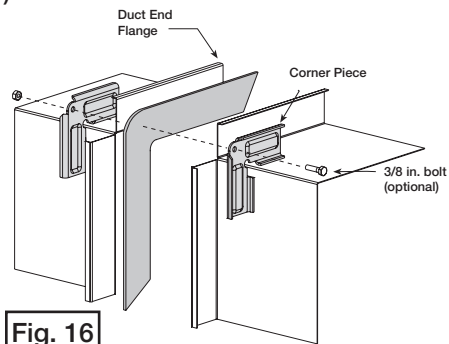

Fig. 16

## Damper Maintenance

Dampers do not typically require maintenance as long as they are kept dry and clean. If cleaning is necessary, use mild detergents or solvents. If lubrication is desired for components such as axle bearings, jackshaft bearings and jamb seals, do not use oil-based lubricants or any other lubricants that attract contaminants such as dust.

Dampers and their actuator(s) must be maintained, cycled, and tested a minimum in accordance with:

- The latest editions of NFPA 80, 90A, 92A, 92B, 101, 105, UL864, AMCA 503-03 and local codes.
- Actuator manufacturer recommendations.

## Damper Troubleshooting

The following is a possible cause and correction list for common concerns with the dampers.

Symptom	Possible Cause	Corrective Action
Damper does not fully open and/or close	Frame is 'racked' causing blades to bind on jamb seals	Adjust frame such that it is square and plumb
	Actuator linkage loose	Close damper, disconnect power, adjust and tighten linkage
	Defective motor	Replace
	Screws in damper linkage	Damper installed too far into wall. Move out to line as designated on damper label
	Contaminants on damper	Clean with a non-oil based solvent (see Damper Maintenance)
RRL or TOR sensor tripped	Heat	Push reset button located on backside of RRL or TOR
Damper does not operate	No power supplied to the actuator	Add power supply



Copyright © 2010 Greenheck Fan Corporation  
461666 FSD-3XXV Rev. 10 oct 2010