

Refer to Greenheck Installation Instructions: Part #453343

Dampers Installed In Gypboard Ceiling Wood Truss With Gypboard Ceiling

- Maximum size of permitted opening equals maximum size of available listed ceiling radiation dampers.
- Opening in ceiling membrane may be up to one inch larger than the nominal size of the ceiling radiation damper (i.e. a 12 in. x 12 in. (nominal) ceiling radiation damper could have a maximum ceiling membrane opening of 13 in. x 13 in.).
- Connection of ceiling radiation damper:
 1. Measure the actual spacing between the wood framing members and cut the vertical leg of the mounting angle to length plus six inches. Two mounting angles are required. Fold up three inches at 90° at both ends of the mounting angle and attach it to the wood frame with minimum of two each #6 penny nails or #8 screws.
 2. The damper is attached to the mounting angle by sheet metal screws (minimum of two screws per angle for rectangular dampers and minimum of one screw per angle for round dampers).
 3. On the sides opposite the retaining angles, a three inch long (minimum) mounting angle is required. Make attachments as shown in **Figure 1**; make two attachments minimum per mounting angle for rectangular dampers and one attachment minimum per mounting angle for round dampers. Bottom leg of mounting angle rests on the ceiling material.
 4. See **Figure 1** for further details.
- **Figure 2** and **Figure 3** show top views of a rectangular and round damper installation, respectively.
- **Figure 4** shows the installation of a damper, with top and bottom extensions which extends three inches above and below the rated ceiling.
- Fiberglass or metal duct may be attached to either the top or bottom of the damper or both.
- If flexible duct is used, it shall be fastened to the diffuser neck with a steel clamp or #16 SWG minimum wire or cable ties.

Models CRD-1, CRD-1LP, and CRD-2 may be installed as shown in **Figure 1** and **Figure 4**.

Figure 1

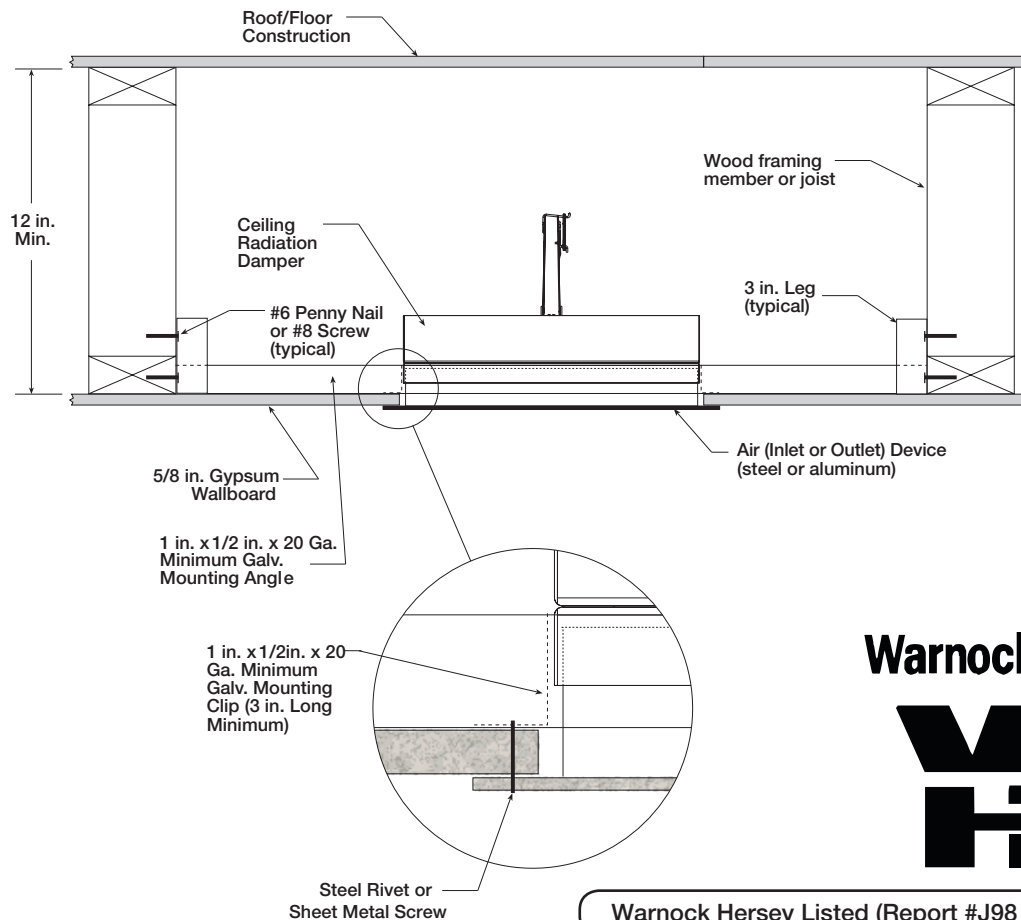

Warnock Hersey

Warnock Hersey Listed (Report #J98 18453, #J99 13961)

Dampers Installed In Gypboard Ceiling (cont.)

Figure 2

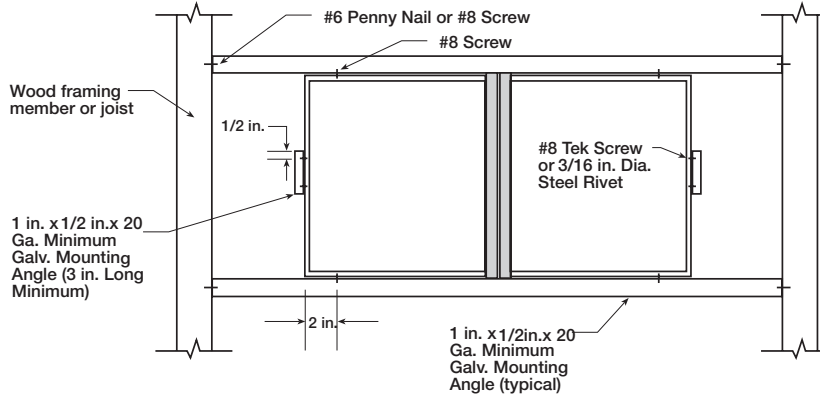

Figure 3

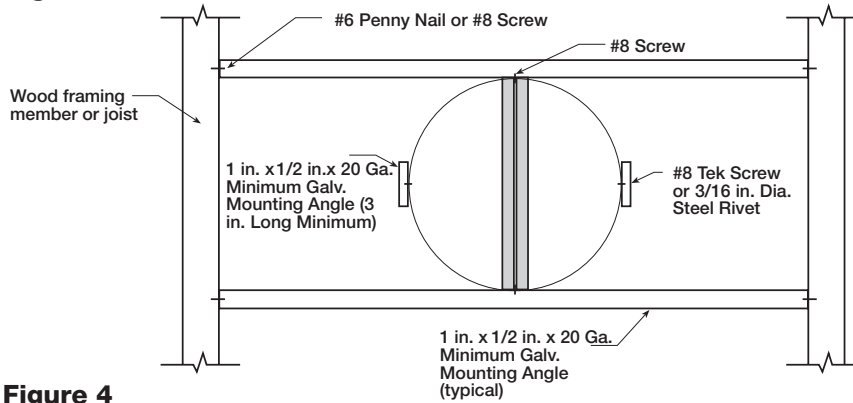
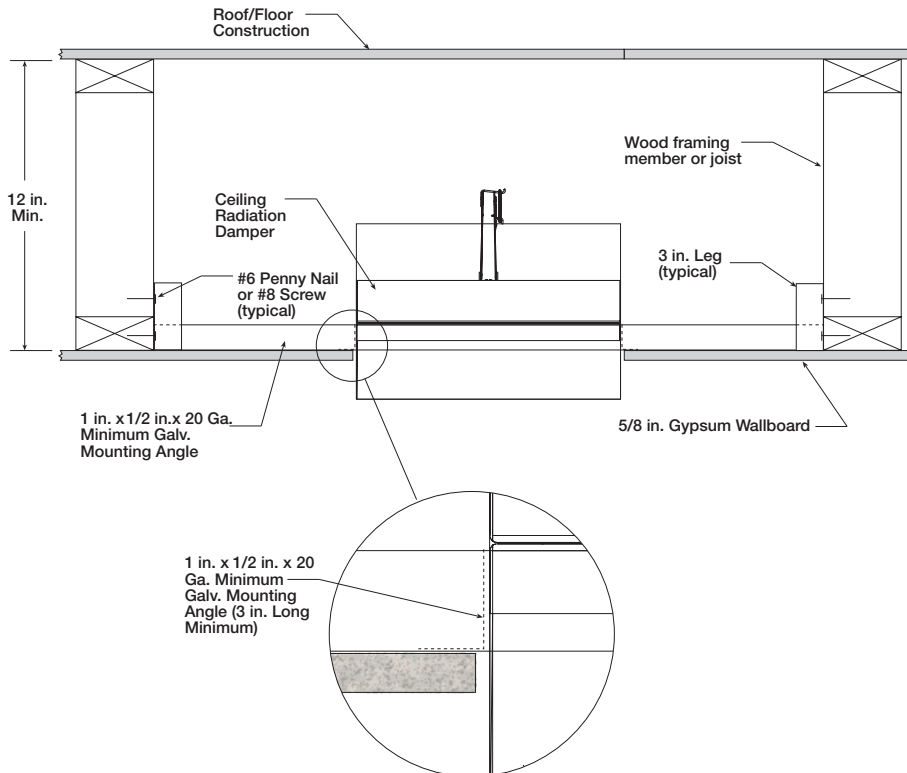

Figure 4



GREENHECK

Copyright © 2010 Greenheck Fan Corporation
460637 CRD Supplement Rev 6 Feb 2010