

Installation, Operation and Maintenance Manual

Please read and save these instructions for future reference. Read carefully before attempting to assemble, install, operate or maintain the product described. Protect yourself and others by observing all safety information. Failure to comply with instructions could result in personal injury and/or property damage!

Model ERM



General Safety Information

Only qualified personnel should install this system. Personnel should have a clear understanding of these instructions and should be aware of general safety precautions. Improper installation can result in electric shock, possible injury due to coming in contact with moving parts, as well as other potential hazards. Other considerations may be required if high winds or seismic activity are present. If more information is needed, contact a licensed professional engineer before moving forward.

DANGER

Always disconnect power before working on or near this equipment. Lock and tag the disconnect switch or breaker to prevent accidental power up.

CAUTION

When servicing the unit, the internal components may be hot enough to cause pain or injury. Allow time for cooling before servicing.

CAUTION

Precaution should be taken in explosive atmospheres.

1. Follow all local electrical and safety codes, as well as the National Electrical Code (NEC), the National Fire Protection Agency (NFPA), where applicable. Follow the Canadian Electric Code (CEC) in Canada.
2. All moving parts must be free to rotate without striking or rubbing any stationary objects.
3. Unit must be securely and adequately grounded.
4. Do not spin fan wheel faster than maximum cataloged fan RPM. Adjustments to fan speed significantly affects motor load. If the fan RPM is changed, the motor current should be checked to make sure it is not exceeding the motor nameplate amps.
5. Do not allow the power cable to kink or come in contact with oil, grease, hot surfaces or chemicals. Replace cord immediately if damaged.
6. Verify that the power source is compatible with the equipment.
7. Never open access doors to the unit while it is running.

Receiving

Upon receiving the product, check to make sure all items are accounted for by referencing the bill of lading to ensure all items were received. Inspect each crate for shipping damage before accepting delivery. Notify the carrier if any damage is noticed. The carrier will make notification on the delivery receipt acknowledging any damage to the product. All damage should be noted on all the copies of the bill of lading which is countersigned by the delivering carrier. A Carrier Inspection Report should be filled out by the carrier upon arrival and the Traffic Department. If damaged upon arrival, file claim with carrier. Any physical damage to the unit after acceptance is not the responsibility of Greenheck Fan Corporation.

Unpacking

Verify that all required parts and the correct quantity of each item have been received. If any items are missing, report shortages to your local representative to arrange for obtaining missing parts. Sometimes it is not possible that all items for the unit be shipped together due to availability of transportation and truck space. Confirmation of shipment(s) must be limited to only items on the bill of lading.

Handling

Units are to be rigged and moved by the provided lifting points or fork lifting points (see page 4). Handle each piece in such a way as to keep from scratching or chipping the coating. Damaged finish may reduce ability of the unit to resist corrosion.

Storage

Units are protected against damage during shipment. If the unit cannot be installed and operated immediately, precautions need to be taken to prevent deterioration of the unit during storage. The user assumes responsibility of the unit and accessories while in storage. The manufacturer will not be responsible for damage during storage. These suggestions are provided solely as a convenience to the user.

Inspection and Maintenance during Storage

While in storage, inspect units once per month. Keep a record of inspection and maintenance performed. If moisture or dirt accumulations are found on parts, the source should be located and eliminated. At each inspection, rotate all moving components by hand ten to fifteen revolutions to distribute lubricant on motor and bearings. If paint deterioration begins, consideration should be given to touch-up or repainting. Units with special coatings may require special techniques for touch-up or repair.

Machined parts coated with rust preventive should be restored to good condition promptly if signs of rust occur. Immediately remove the original rust preventive coating with petroleum solvent and clean with lint-free cloths. Polish any remaining rust from surface with crocus cloth or fine emery paper and oil. Do not destroy the continuity of the surfaces. Wipe clean thoroughly with Tectyl® 506 (Ashland Inc.) or the equivalent. For hard to reach internal surfaces or for occasional use, consider using Tectyl® 511M Rust Preventive or WD-40® or the equivalent.

Table of Contents

Storage	2
Electrical Connection	2
Mounting	2
Start-Up	3
Drive Belt	4
Air Seals	4
Dimensional Data & Specifications	5
Installation Clearances	5
Routine Maintenance	
Energy Recovery Wheel	6
Energy Recovery Wheel Maintenance	6
Energy Recovery Wheel Access	6
Removal of Segments	6
Cleaning the Energy Recovery Wheel	6
Energy Recovery Wheel Belt	6
Energy Recovery Wheel Bearings	6
Parts List	7
Troubleshooting	7
Maintenance Log	Backcover
Warranty	Backcover

Electrical Connections

The electrical supply must be compatible with that shown on the wheel drive motor nameplate: voltage, phase, and amperage capacity (see page 5 for specific requirements). Units are supplied with a receptacle for the cassette plug and service box for wiring. Connect the ERM wiring directly to blower wiring or to blower fan relay to power the ERM whenever the fan is in operation. All wiring must be properly fused and conform to local and national electrical codes.

Do not operate the ERM for any extended period without airflow across the energy wheel as the drive motor is cooled by the airflow.

Mounting

IMPORTANT

ERM must be installed such that the energy wheel cassette slides in and out of the cabinet parallel to the floor.

NOTE

To reduce unit weight for handling purposes, the cassette may be removed from the cabinet.

The ERM is shipped with a mounting kit containing hanging brackets. These brackets will support the ERM in either a vertical or horizontal position for design flexibility.

To hang the ERM:

1. To remove the cassette from the cabinet, remove the access panel and unplug the wheel drive motor at the electrical receptacle in the cabinet.
2. Replace the access panel before mounting to ensure squareness.
3. Use the brackets shown in Figure 1 to secure the ERM. These brackets are designed for 3/8 in. threaded hanging rods.
4. To reinstall the cassette in the mounted ERM cabinet, align the cassette sliders with the channels in the cabinet and slide the cassette in place. Replace access panel when finished.

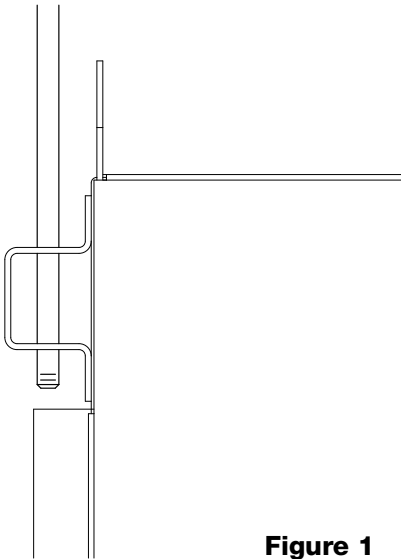

Figure 1

Start-Up

DANGER

Electric shock hazard. Can cause injury or death. Before attempting to perform any service or maintenance, turn the electrical power to unit to OFF.

CAUTION

Use caution when removing access panels or other unit components, especially while standing on a ladder or other potentially unsteady base. Access panels and unit components can be heavy and serious injury may occur.

Every installation requires a comprehensive start-up to ensure proper operation of the unit. As part of that process, the following information must be recorded. Should an issue arise which requires factory assistance, this important information will allow unit experts to provide quicker resolve. Qualified personnel should perform start-up to ensure safe and proper practices are followed.

Unit Model Number _____
(e.g. ERM-58H-15)

Unit Serial Number _____
(e.g. 04C99999 or 10111000)

Energy Wheel Date Code _____
(e.g. 0450)

Start-up date _____
(MM/DD/YYYY)

Start-up Personnel Name _____

Start-up Company _____

Phone Number _____

The ERM models contain a total energy recovery wheel. The wheels are inspected for proper mechanical operation at the factory. However, during shipping and handling, shifting can occur that may affect wheel operation. The wheel is accessible through the cassette access panel.

Turn the energy recovery wheel by hand to verify free operation. The wheel should rotate smoothly at approximately 50-60 rpm and should not wobble. If the wheel does not rotate when power is applied, it may be necessary to adjust excessively tight diameter air seals.

WARNING

Do not operate Energy Recovery Module without duct filters or screens installed. The filters and screens prevent the entry of foreign objects such as leaves, birds, etc.

Drive Belt

Inspect the drive belt. Make sure the belt rides smoothly through the pulley and over the rim.

Air Seals

Check that the air seals located around the outside of the wheel and across the center (both sides of wheel) are secure and in good condition. Air seal clearance is determined by placing a sheet of paper, to act as a feeler gauge, against the wheel face. To access seals, remove cassette access panel. To adjust their seals, loosen all eight seal retaining screws. These screws are located on the bearing support that spans the length of the cassette through the wheel center. Tighten the screws so the air seals tug slightly on the sheet of paper.

Replace cassette into ERM cabinet, plug in wheel drive, replace access door and apply power. Confirm that the wheel rotates freely at about 50-60 rpm.

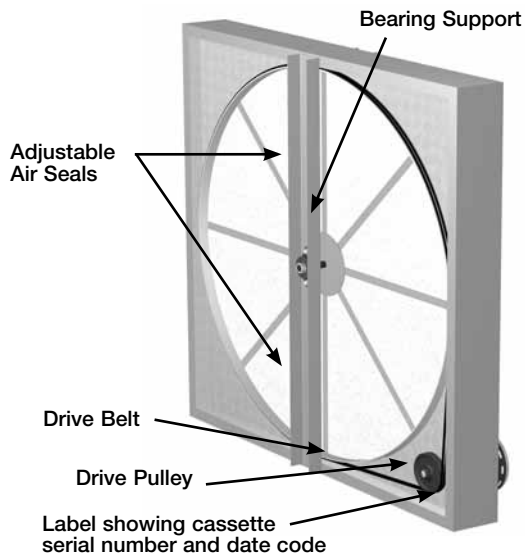

Dimensional Data and Specifications

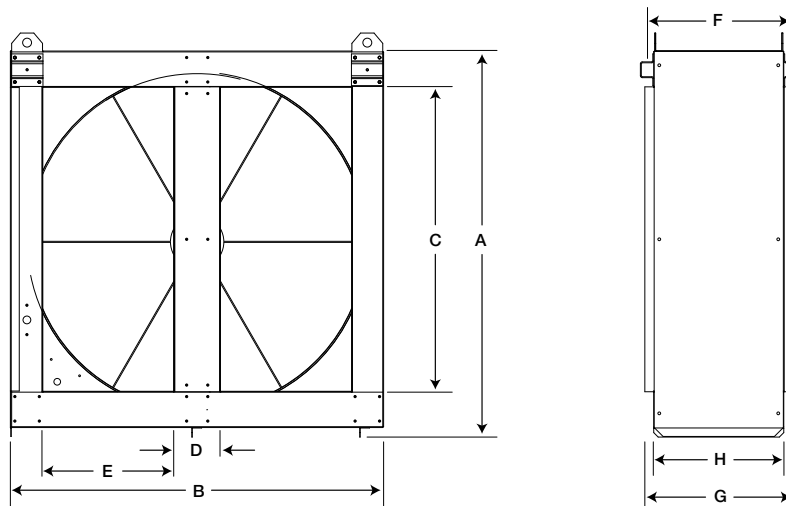

Model	A	B	C	D	E	F	G	H	Voltage	Hertz	Phase	Amps	Motor HP	Weight (lbs.)	
														Cabinet	Cassette
ERM-58H-15	62½	62½	54¼	7½	24¼	21¾	18½	16½	200-230/460	60	3	1.3-1.2/0.6	1/4	150	290
ERM-58H-30	62½	62½	54¼	7½	24¼	21¾	18½	16½	200-230/460	60	3	1.3-1.2/0.6	1/4	150	290
ERM-64H-30	68¼	68¼	60¼	7½	27	25¼	22	20	200-230/460	60	3	1.3-1.2/0.6	1/4	170	363
ERM-74H-30	78¼	78¼	70¼	8½	30½	25¼	22	20	200-230/460	60	3	1.3-1.2/0.6	1/4	205	454

All dimensions shown are in inches.

Installation Clearances

Provide proper clearance for cassette inspection, service or removal. Do not install ducting, piping or wiring where it will interfere with cassette removal. Wheel cassette does not slide out. Access to wheel for service must be provided through ductwork.

Routine Maintenance

Once the unit has been put into operation, a routine maintenance program should be set up to preserve reliability and performance. Items to be included in this program are:

Energy Recovery Wheel

- Check for cleanliness - clean if required
- Check belt for wear
- Check pulley, bearings, and motor

Energy Recovery Wheel Maintenance

Annual inspection of the energy recovery wheel is recommended. Units ventilating smoking lounges and other non-clean air spaces should have energy recovery wheel inspections more often based upon need. Inspections for smoke ventilation applications are recommended bimonthly to quarterly until a regular schedule can be established.

Accessing the Energy Recovery Wheel

Disconnect power to the ERM unit. Remove access panel and UNPLUG the wheel drive motor. Pull the cassette halfway out.

Removing the Energy Recovery Wheel Segments

Rotate the wheel by hand clockwise (as viewed from the pulley side of cassette) to check each segment. Steel retainers are located on the inside of the wheel rim (see diagram). Push the retainer toward center of wheel, then lift up and away to release segments.

Reverse the above instructions to reinstall the energy recovery wheel segments.

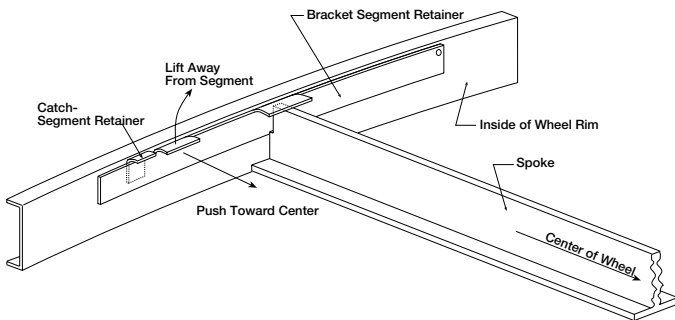

IMPORTANT

Place retainers back in the original position before rotating the energy recovery wheel. Otherwise, damage to the retainer will occur.

Cleaning the Energy Recovery Wheel

If the wheel appears excessively dirty, it should be cleaned to ensure maximum operating efficiency. Only excessive buildup of foreign material needs to be removed. Discoloration and staining of energy recovery wheel does not affect its performance.

Thoroughly spray wheel matrix with household cleaner such as Fantastik® or equivalent. Gently rinse with warm water and using a soft brush remove any heavier accumulation. A detergent/water solution can also be used. Avoid aggressive organic solvents, such as acetone. The energy recovery wheel segments can be soaked in the above solution overnight for stubborn dirt or accumulation.

After cleaning is complete, shake the excess water from the wheel or segments. Dry wheel or segments before placing them back into the cassette. Place wheel or segments back into cassette by reversing removal procedures.

CAUTION

Do not clean energy recovery wheel segments with water in excess of 140°F (60°C).

Do not dry energy recovery wheel segments in air in excess of 140°F (60°C).

The use of a pressure washer to clean segments is not recommended. Damage could result.

Energy Recovery Wheel Belt

Inspect belts each time filters are replaced. Belts that look chewed up or are leaving belt dust near the motor pulley may indicate a problem with the wheel. Be sure to inspect wheel for smooth and unrestricted rotation. If a belt requires replacement, contact the local Greenheck representative. Instructions for replacement will ship with the new belt.



Wheel Belt & Pulley

Energy Recovery Wheel Bearing

In the unlikely event that a wheel bearing fails, the bearing is behind a removable plate on the wheel support beam (slide cassette halfway out of cabinet for access). Contact the local Greenheck representative for detailed instructions on how to replace the bearing.



Wheel Bearing

Parts List

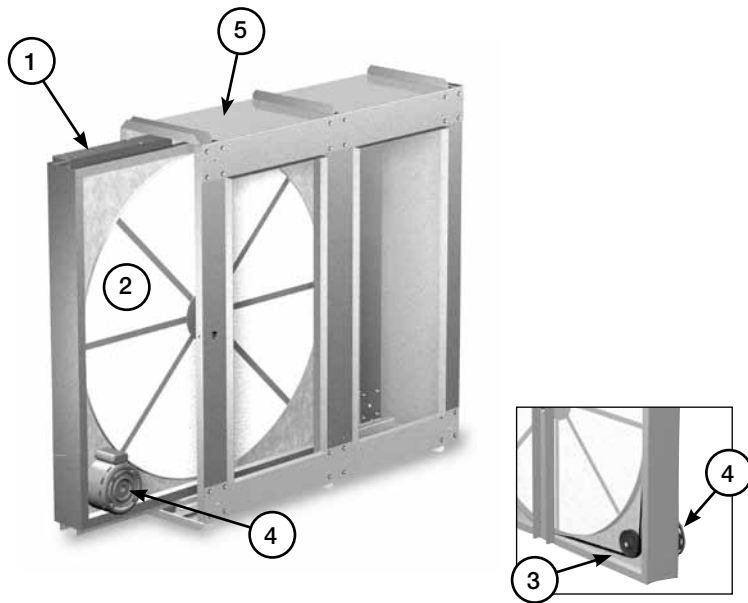

1. Cassette
2. Energy Wheel Segments
3. Energy Wheel Drive Belt and Pulley
4. Energy Wheel Motor
5. Cabinet

The ERM mounting bracket kit has a separate parts list.

Troubleshooting

Symptom	Possible Cause	Corrective Action
Energy Wheel does NOT turn	Air seals are too tight.	See air seals under Start-Up section.
	Broken belt.	Replace.
	No power to wheel motor.	Make sure wheel drive is plugged in. Verify power is available.
Energy Wheel runs intermittently	Wheel motor overloads are tripping due to rubbing between wheel and air seals.	Recheck air seals, make sure they are not too tight. See Air Seals under Start-Up section.

Maintenance Log

Date _____ Time _____ AM/PM

Notes: _____

Date _____ Time _____ AM/PM

Notes: _____

Date _____ Time _____ AM/PM

Notes: _____

Date _____ Time _____ AM/PM

Notes: _____

Date _____ Time _____ AM/PM

Notes: _____

Date _____ Time _____ AM/PM

Notes: _____

Warranty

Greenheck warrants this equipment to be free from defects in material and workmanship for a period of five year from the shipment date. This warranty limits our responsibility to repairing or replacing—to the original purchaser—any part or parts of said equipment which prove to be defective upon examination by representatives of Greenheck. Additionally, said part(s) will be returned to and received by the factory only after prior authorization, with transportation charges prepaid.

Greenheck shall not be obligated under this warranty for payment of any delivery, removal or installation charges with regard to repair or replacement of any defective part(s).

Motors are warranted by the motor manufacturer for a period of one year. Should motors furnished by Greenheck prove defective during this period, they should be returned to the nearest authorized motor service station. Greenheck will not be responsible for any removal or installation costs.

As a result of our commitment to continuous improvement, Greenheck reserves the right to change specifications without notice.

Greenheck Model ERM catalog provides additional information describing the equipment, fan performance, available accessories, and specification data.

AMCA Publication 410-96, Safety Practices for Users and Installers of Industrial and Commercial Fans, provides additional safety information. This publication can be obtained from AMCA International, Inc. at www.amca.org.

