



## Models RBU/RBUMO/RDU Upblast Propeller Roof Fans Belt Drive and Direct Drive

### Installation, Operation and Maintenance Manual



Greenheck Model RBU, RBUMO and RDU fans are thoroughly inspected and test run at the factor. However, damage may occur during handling and shipping. Consequently, it is important that the unit be carefully inspected for visible and concealed damage before beginning installation. Report any damage to the shipper immediately. In addition, assure all accessory items are accounted for.

#### INSTALLATION

##### LIFTING

Attach a suitable chain or strap to the four windband mounting brackets, which are designed to be used as lifting lugs (Fig. 1). **Do not lift the fan by the motor, belt tube, damper frame, windband or accessories.**

Carefully lift the fan to the roof curb and install fasteners in all holes provided in the unit base. The windband does not need to be removed for the lifting operation.

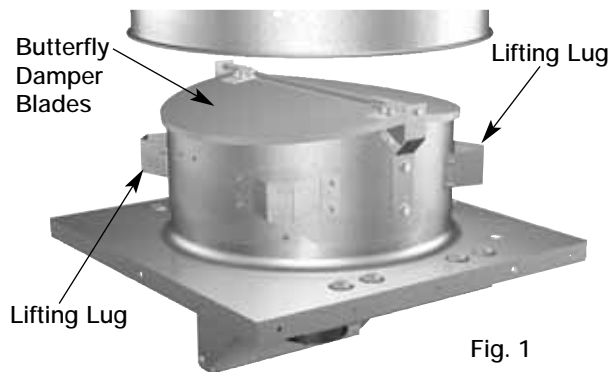

#### SERVICE ACCESS

##### MOTOR OUT OF AIRSTREAM

Model RBUMO simplifies inspection and servicing with the "motor out of the airstream" design. A removable motor cover enables quick and easy access to the motor, belt, and drives from the roof deck (Fig. 2).

Servicing of propeller and bearings can easily be accomplished by removing the fan panel/windband assembly from the fan base.

##### REMOVABLE WINDBAND

The windband can be removed by removing the bolts from the four windband mounting brackets. With the windband removed, access to the fan can be gained through the butterfly dampers. This service feature applies to models RBU, RBUMO and RDU (Fig. 1).



## ELECTRICAL CONNECTIONS

Before electrical connections are made, the supply voltage, phase and ampere capacity must be checked for compatibility with the fan motor. In addition, the supply wiring must be properly fused and conform to local and national electrical codes.

The supply wires are then connected to an optional safety disconnect switch (if ordered) or wired directly to the motor.

For belt drive units in Emergency Smoke Removal installations, the electrical supply must be kept out of the airstream. They may also require an isolated power supply so that if power is cut to the building in the event of a fire, the fan will continue to operate. Check the local and national electrical codes for emergency smoke removal fans.

### WARNING!

Disconnect and secure to the "off" position all electrical power to the fan prior to inspection or service.

Caution must be used when working around the fusible link damper lifters. They may release the dampers unexpectedly.

Models RBU, RBUMO and RDU may have fusible link damper lifters and all RBUMO models with high temperature options have fusible link damper lifters under spring tension. RBUMO fans UL listed as "Power Ventilators For Smoke Control Systems" in sizes 42, 48, 54 and 60 have extra heavy duty fusible link damper lifters under high spring tension that, for safety reasons, must be pinned to prevent accidental release. See Fig. 3 below for details on how to secure the lifter arms.

**FAILURE TO COMPLY WITH THESE SAFETY PRECAUTIONS MAY RESULT IN SERIOUS INJURY OR DEATH!**

## For Models RBUMO with high temperature option - UL Listed

### WARNING!

These fans have extra heavy duty fusible link damper lifters under very high spring tension that must be pinned so they can not be accidentally tripped when servicing the fan. The fusible link damper lifters are located under the butterfly damper blades, refer back to Fig. 1. Fig. A shows where the two safety pins will be located when shipped from the factory. When maintenance is being performed on the fan, the pins MUST be moved from Fig. A position to Fig. B position. Fig. A shows where the two safety pins are placed when the fan is in service. Fan sizes 20, 24, 30 and 36 do not have the ability to be pinned when servicing due to differences in lifter designs. In either case, extreme care must be taken when working around the damper lifter assemblies or serious bodily injury or death may result.

	- IMPORTANT -
	<p><b>ELECTRICAL</b> - If fan motor is NOT thermally protected, remote overload protection must be installed having adequate rating as to voltage, frequency, horsepower, and full load current per phase. Where connected to a circuit protected by fuses, use time delay fuses. For supply connection use wires rated for at least 90°C (194°F).</p> <p><b>INSTALLATION</b> - When connecting electrical power to this fan, do not restrict motor movement. Motor must have sufficient movement for possible future belt or wheel adjustment. 454975</p>

Listed Power Ventilator For Smoke Control Systems 76Y9

Models RBUMO with High Temperature Option - UL Listed will bear the label shown above. For fan sizes 42, 48, 54 and 60 Figs. A and B apply.

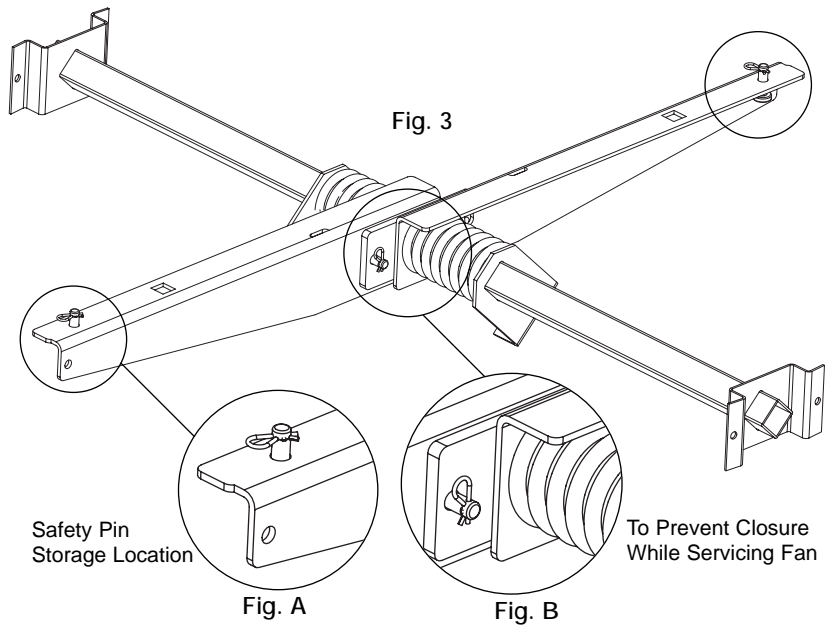

## PRESTARTING CHECKS

Check all fasteners and set screws for tightness. This is especially important for bearing set screws.

The propeller should rotate freely and not rub on the fan panel venturi. Rotation direction of the propeller should be checked by momentarily turning the unit on. Rotation should be in the same direction as the rotation decal affixed to the unit or as shown in Fig. 4. For 3-phase installations, fan rotation can be reversed by simply interchanging any two of the three electrical leads. For single phase installations, follow the wiring diagram located on the motor.

### FOR BELT DRIVE FANS

The adjustable motor pulley is preset at the factory for the specified fan RPM. Fan speed can be increased by closing or decreased by opening the adjustable pulley. Two or three groove variable pitch pulleys must be adjusted an equal number of turns open. Any increase in fan speed represents a substantial increase in horsepower required from the motor. Always check motor load amperage and compare to name plate rating when changing fan speed.

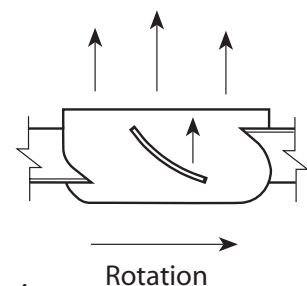

## ROUTINE MAINTENANCE

### WARNING!

DISCONNECT AND SECURE TO THE "OFF" POSITION ALL ELECTRICAL POWER TO THE FAN PRIOR TO INSPECTION OR SERVICING. FAILURE TO COMPLY WITH THIS SAFETY PRECAUTION COULD RESULT IN SERIOUS INJURY OR DEATH.

Once the fan has been put into operation, a periodic maintenance program should be set up to preserve the reliability and performance of the fan. Items to be included in this program are:

- BELTS
- BEARINGS
- FASTENERS
- SET SCREWS
- LUBRICATION
- REMOVAL OF DUST/DIRT

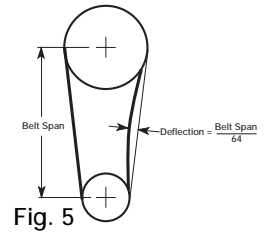

Fig. 5

### BELTS

Premature belt failures are frequently caused by improper belt tension (either too tight or too loose) or misaligned pulleys. The proper tension for operating a V-belt is the lowest tension at which the belts will not slip at peak load conditions. For initial tensioning, the proper belt deflection half way between pulley centers is 1/64 inch for each inch of belt span. For example, if the belt span is 64 inches, the belt deflection should be one inch using moderate thumb pressure at midpoint of the drive (Fig. 5).

Check belt tension two times during the first 24 hours of operation and periodically thereafter. To adjust belt tension, simply loosen four fasteners (two on each side of the motor plate) and slide the motor plate away from the fan shaft until proper belt tension is attained. On some fans, fasteners attaching the motor to the motor plate must be loosened in order to adjust the belt.

It is very important that the drive pulleys remain in proper alignment after adjustments are made. Misalignment of pulleys will result in premature belt wear, noise, vibration and power loss. See Fig. 6.

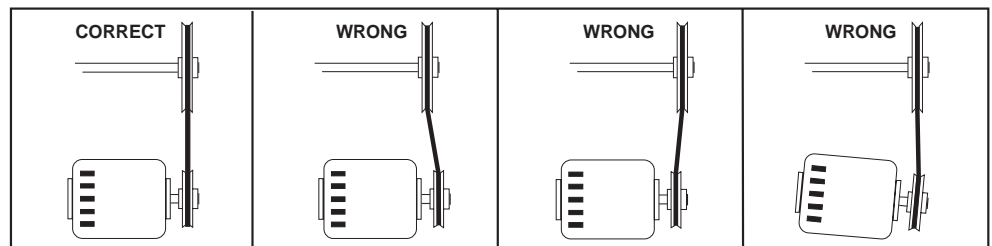

Fig. 6

### BEARINGS (For belt drive fans only)

Bearings are the most critical moving part of the fan and should be inspected at periodic intervals. Locking collars, set screws and fasteners attaching the bearings to the bearing plate, must be checked for tightness. In a clean environment and temperatures above 32°F/below 200°F, fan shaft bearings with grease fittings should be lubricated semi-annually using a high quality lithium based grease. If unusual environmental conditions exist, temperatures below 32°F/above 200°F, moisture or contaminants, more frequent lubrication is required.

With the unit running, add grease very slowly with a manual grease gun until a slight bead of grease forms at the seal. Be careful not to unseat the seal by over lubricating or using excessive pressure. Bearings without grease fittings are lubricated for life.

### FASTENERS AND SET SCREWS

Any fan vibration has a tendency to loosen mechanical fasteners. A periodic inspection should include checking all fasteners and set screws for tightness. Particular attention should be paid to set screws attaching the propeller to the shaft and the shaft to the bearings. Loose bearing set screws will lead to premature failure of the fan shaft.

### LUBRICATION

Refer to the paragraph on bearings for bearing lubrication. Many fractional horsepower motors installed on the smaller fans are lubricated for life and require no further attention. Motors equipped with oil holes should be oiled in accordance with the manufacturer's instructions printed on the motor. Use a high grade SAE 20 machine oil and use caution not to over lubricate. Motors supplied with grease fittings should be greased according to directions printed on the motor.

### REMOVAL OF DUST AND DIRT

Dirt clogs cooling openings on the motor housing, contaminates bearing lubricant, and collects on propeller blades causing severe imbalance if left unchecked. The exterior surface of the motor, fan panel and entire propeller should be thoroughly cleaned periodically. Use caution and do not allow water or solvents to enter the motor or bearings. Under no circumstances should motors or bearings be sprayed with steam or water.

### DAMPER INSPECTION AND SERVICE

**CAUTION: Butterfly dampers on units supplied with optional spring lifter bars are under spring tension and will open forcefully if the fusible link is released.** Butterfly dampers should be inspected for proper operation at each service interval. Check for freedom of movement and general condition of the damper blades and hinge rods.

# Parts List

## RBU Parts List

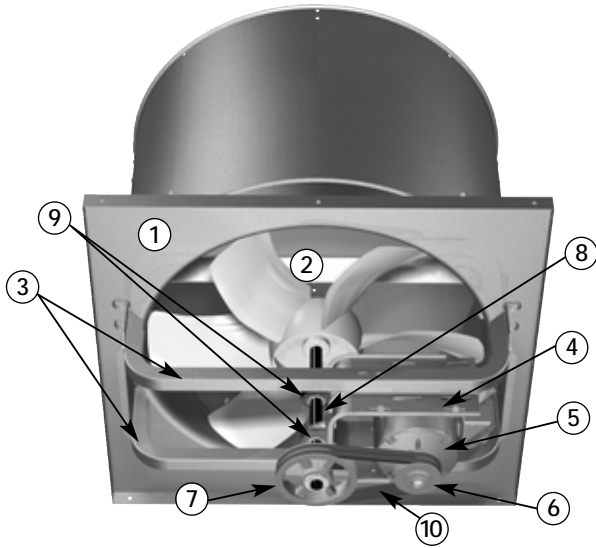

## RDU Parts List

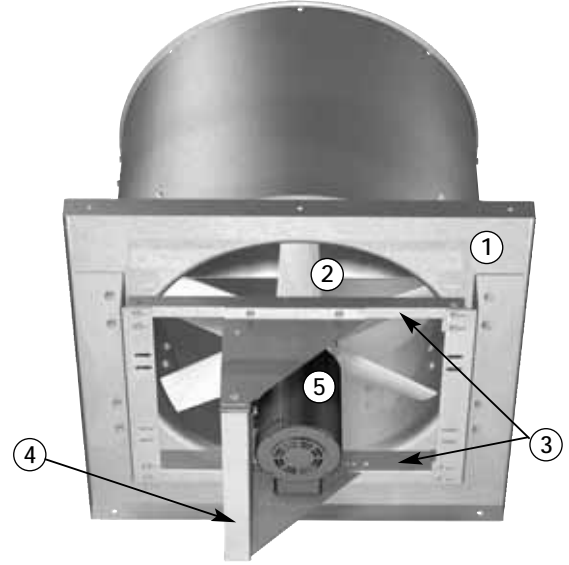

## RBUMO Parts List

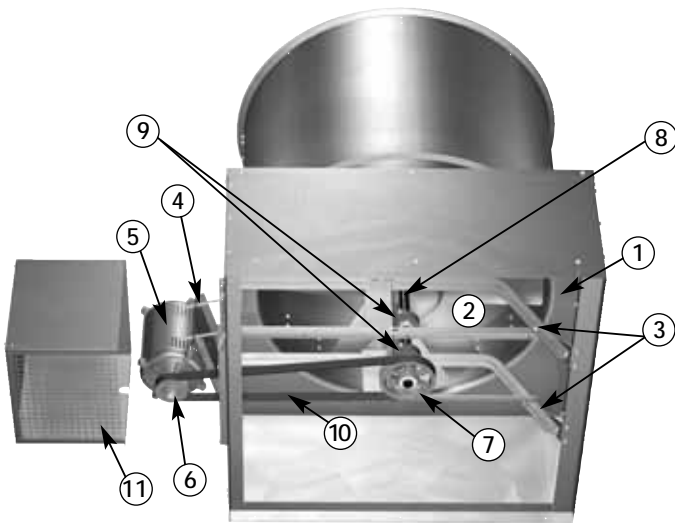

1. Fan Panel
2. Propeller
3. Drive Frame Channel (2)
4. Motor Plate
5. Motor
6. Motor Pulley
7. Shaft Pulley
8. Fan Shaft
9. Bearings (2)
10. Belt
11. Motor Cover (RBUMO only)

### Warranty

Greenheck warrants this equipment to be free from defects in material and workmanship for a period of one year from the purchase date. Any units or parts which prove to be defective during the warranty period will be replaced at our option when returned to our factory, transportation prepaid.

Motors are warranted by the motor manufacturer for a period of one year. Should motors furnished by Greenheck prove defective during this period, they should be returned to the nearest authorized motor service station. Greenheck will not be responsible for any installation or removal costs.

*As a result of our commitment to continuous research, Greenheck reserves the right to change specifications without notice.*

