



**GREENHECK**



# Part Number 455050

1 1/2" Stand Off Brackets and  
Manual Quadrants on  
(MBD-10) Manual Balancing Dampers

## FIELD INSTALLATION INSTRUCTIONS

| No. | Qty. | Description              | Part Number |
|-----|------|--------------------------|-------------|
| 1   | 1    | 5.5" Blade Axle Pin      | 452899      |
| 2   | 1    | Blade Axle Ring          | 451890      |
| 3   | 1    | Manual Quadrant          | 452842      |
| 4   | 1    | 1 1/2" Stand Off Bracket | 649607      |
| 5   | 2    | #10 x 1/2 HWH TEK ZP     | 415555      |

**TOOLS REQUIRED:**  
Hammer  
5/16" Driver  
Electric Drill

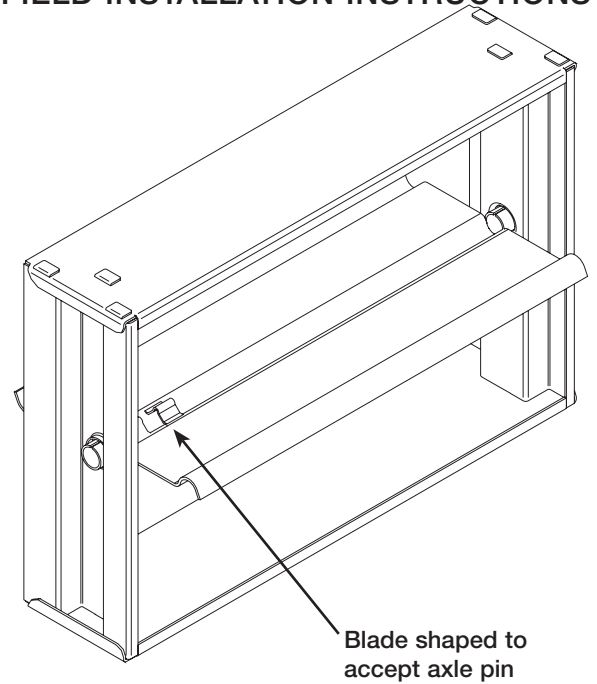
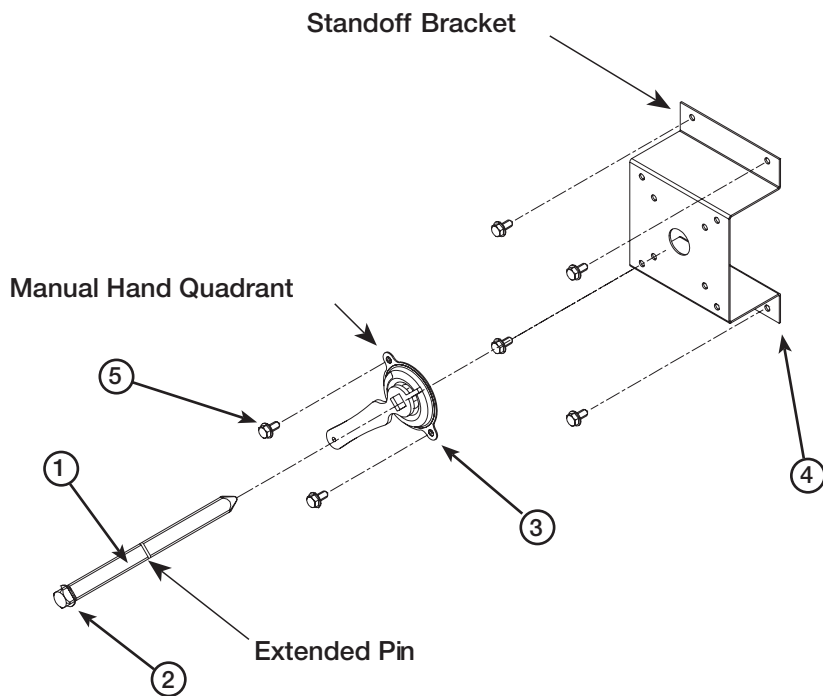

Before mounting the damper in the duct, note which axle bearing will accept a square axle.  
The manual quadrant is to be mounted on that side of the damper.

1. Mount the damper in the duct making sure to place the square axle bearing on the side the manual quadrant is to be mounted.
2. Cut a hole in the duct over the square axle bearing large enough for the axle pin to slide into place.
3. Slide the axle pin (2) through the manual quadrant (3) and then through the stand off bracket (4).
4. With the axle pin (2), manual quadrant (3), and stand off bracket (4) assembled, pound the axle pin into the damper until the clip (2) on the axle pin (1) presses firmly against the manual quadrant. Make sure the blade of the damper is closed and the lever on the manual quadrant is in the closed position before attaching the assembly to the damper.
5. Screw the manual quadrant (3) through the holes in the stand off bracket (4) with two self drilling screws (5) (Provided).
6. Screw the stand off bracket (4) to the duct with four self drilling screws (5) (provided by others).

