

These installation instructions apply to 3 hour rated ceiling radiation dampers mounted in a ceiling with supports from 1) a ceiling grid system, 2) ductwork above, or 3) structure above. Each type of damper support system is described with damper being mounted in conjunction with various air devices.

“UL CLASSIFIED (see complete marking on product)”
 “UL CLASSIFIED to Canadian safety standards (see complete marking on product)”
 Standard 555, 555S (Listing #R15439)
CSFM California State Fire Marshal
 CRD-1/CRD-2 3226-0987:101
 CRD-60 3226-0981:111

	Page
Damper Supported by a Ceiling Grid System	2
Lay-in Diffuser	2
Lay in Diffuser with Steel Drop	3
Unducted Ceiling Plenum	4
Dampers Supported from Ductwork Above	4
Surface Mounted Air Devices	4-5
Recess Mounted Air Devices	5



	Page
Damper Supported Directly From Structure	5
Ducted Surface Mounted Air Devices	6
Ducted Recess Mounted Air Devices	7
Unducted Surface Mounted Air Devices	7-8
Unducted Recess Mounted Air Devices	8

Ceiling Radiation Damper Application

- Application:** Model CRD-1, CRD-1LP, CRD-2, CRD-3, CRD-60 and CRD-60B are UL labeled ceiling radiation dampers. When installed as shown, they provide appropriate protection for air inlet or outlet penetrations in the ceiling membrane of floor/ceiling and roof/ceiling assemblies with fire resistance ratings of up to 3 hours. Use of these UL and Warnock Hersey labeled ceiling dampers eliminates the need to use “hinged door” type dampers or other alternate protection methods for specific floor/ceiling and roof/ceiling designs shown in the UL FIRE RESISTANCE DIRECTORY (FRD).
- System Components:** All system components (ducts, duct drops, hanger wires, sleeves, and diffuser pan) must be constructed of steel. The diffuser core may be non-ferrous. Grilles may be non-metallic. Flexible duct (if used) must be Class 1 or Class 0 type, bearing the UL listing mark. Maximum length of flex duct shall not exceed 14 feet. The installations and air devices shown in these instructions illustrate general arrangement only. Installations must also incorporate any specific requirements in the FRD. Note that both “Design information - General” and individual ceiling/floor or ceiling/roof design listings apply.
- Ceiling Penetrations:** Ceiling penetration should be located within ceiling tiles or panels without necessitating cuts in the ceiling suspension main runners or cross tees. If required, a maximum of one runner or cross tee may be cut to enable proper damper location and installation. Each cut end shall be supported by a minimum 12 SWG vertical hanger wire. A ½ in. clearance must be maintained between the air inlet/outlet and the cut end of the runner or cross tee.
- Connections:** Connections must be made using #8 sheet metal screws, 3/16 in. tubular steel rivets, tack or spot welds. Use a minimum of one connection per side for rectangular or square dampers and three equally spaced connections for round dampers. Space fasteners a maximum of 6 in. apart. Any W or H dimension larger than 12 in. requires a minimum of two connections per side. All screws or rivet attachments shall be placed a minimum of 3/16 in. from the edge of the damper frame, duct drop, diffuser, or grille frame. When making connections, the ceiling radiation damper may slide over the neck or inside the neck of the diffuser, grille, or inlet/outlet device. **Important: Connections to damper frame must not interfere with damper blade operation.**
- Thermal Blanket:** In those installations where the opening in the ceiling membrane is larger than the ceiling damper (more than 1 in. in any dimension), a Thermal Insulating Blanket (Model TB or QB) must be installed by laying over the exposed surface of the air inlet or outlet device. The Thermal Blanket rests upon and protects exposed portions of the air device and may fit inside adjacent Tee Bars (if any).
- Fusible Link:** All CRD models are shipped from the factory with the blades closed. The fusible link must be installed at time of installation such that the blades are held open as shown at the right.

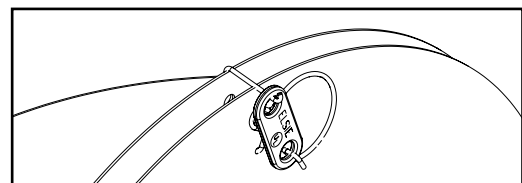

Dampers Supported By A Ceiling Grid System

Exposed Tee Bar ceiling grid systems often use “Lay In” style air inlets and outlets. With attention to the following requirements, the ceiling grid system provides all required support for installation of “Lay In” style ceiling dampers and air inlets and/or outlets.

Ceiling openings up to a 24 in. x 24 in. (576 in.²) maximum are allowable. Maximum size limits of each individual ceiling damper model must be observed.

The four corners of the grid module containing the air device (or the midpoint of the adjacent cross-

tees) shall be directly supported from the structural members of the floor or roof by 12 SWG minimum vertical hanger wires. When the duct extends over the intersections of the grid members, 16 ga. x 1½ in. steel channels with 9/16 in. minimum flanges shall be used to ensure that the grid is supported from structural members by 12 SWG minimum hanger wires. All UL Classified ceiling assemblies require lay-in ceiling panels be cut to fill the remainder of hole openings larger than 24 in. x 24 in. and shall provide a minimum of 3/8 in. bearing on the ceiling grid members.

Lay-In Diffuser Applications

Lay-In Diffuser

- Lay-in diffuser installs directly into exposed Tee bar grid system.
- Ceiling damper attaches to diffuser neck (See Page 1, Paragraph 4).
- Thermal Blanket required (See Page 1, Paragraph 5).
- If flexible duct is used (See Page 1, Paragraph 2), it shall be fastened to the diffuser neck with a steel clamp or #16 SWG minimum wire.

NOTE: (1) The flexible air duct shall not rest on the back surface of the ceiling grid or panels (provide a minimum of 4 in. clearance). (2) The flexible air duct shall not interfere with the closing of the ceiling damper.

Models CRD-1, CRD-1LP, CRD-2, and CRD-60 may be installed as shown in **Figure 1** (Model CRD-2 Illustrated).

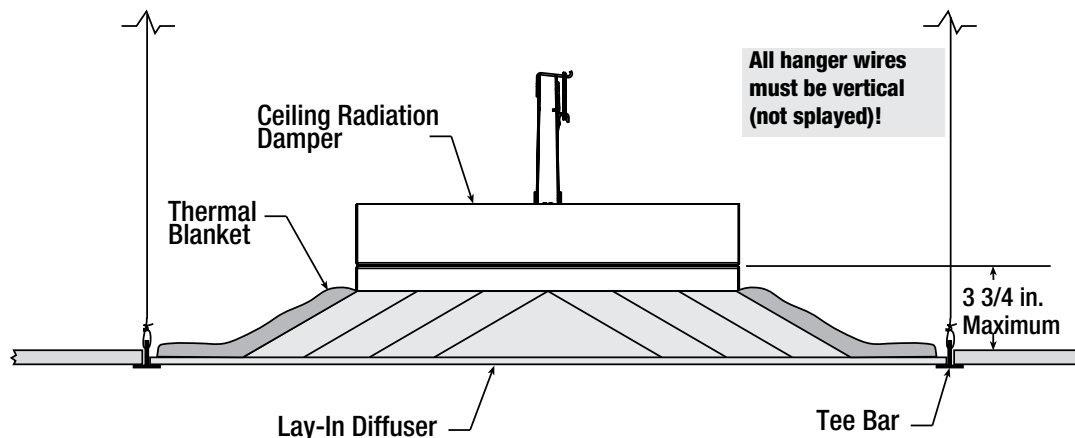

Figure 1

Lay-In Diffuser With Steel Duct Drop

- Lay-in diffuser with steel duct drop installs directly into exposed Tee bar grid system.
- Thermal Blanket required (See Page 1, Paragraph 5)
- Connection of ceiling radiation damper, diffuser neck, and steel duct drop (See Page 1, Paragraph 4) may be satisfied in two ways:
 1. Ceiling radiation damper and diffuser neck may be connected directly to the duct drop (see Detail A, Figure 2).
 2. Ceiling radiation damper may be connected directly to the diffuser neck and then the duct drop connected to the damper (see Detail B, Figure 2).

Models CRD-1, CRD-1LP, CRD-2, and CRD-60 may be installed as shown in **Figure 2** (Model CRD-1 & CRD-1LP Illustrated).

Dampers Supported By A Ceiling Grid System (cont.)

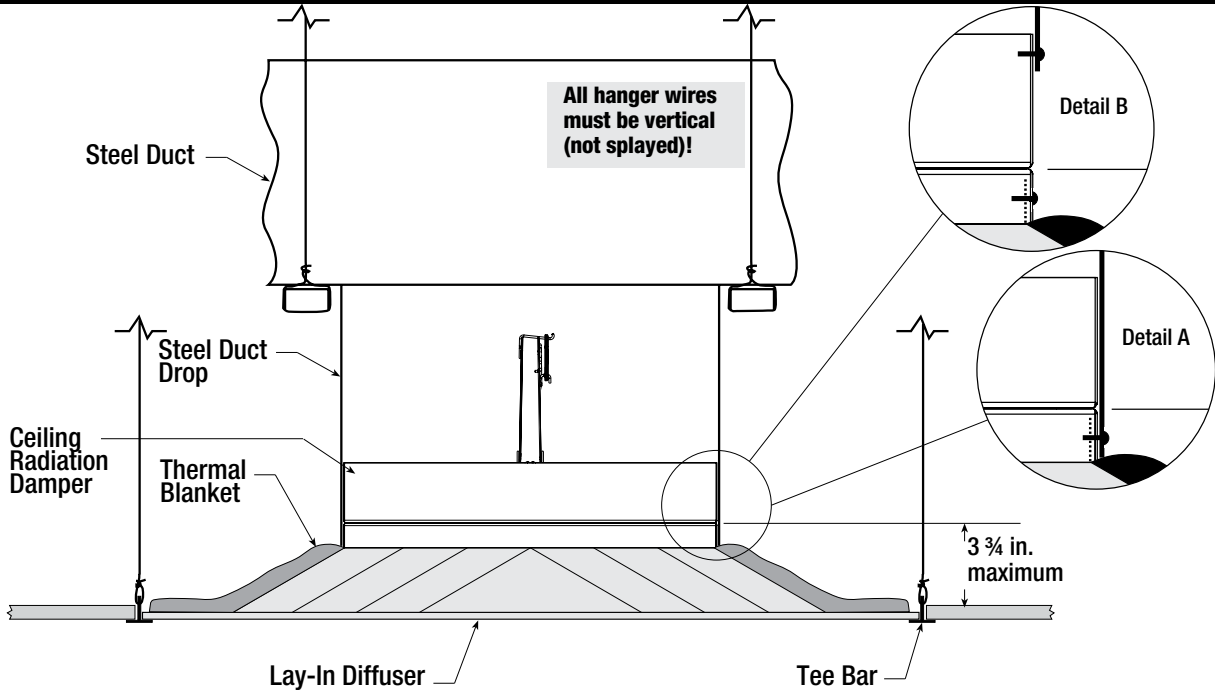

Figure 2

Unducted Ceiling Plenum Return Air Applications

For Models CRD-1, CRD-1LP, CRD-3, & CRD-60

- Ceiling radiation damper is the same size as the ceiling opening and installs directly into the exposed Tee bar grid system opening.
- Damper is supported directly by the grid system and may lay on top of perforated metal (or similar) grille core material.

Models CRD-1, CRD-1LP, CRD-3, and CRD-60 may be installed as shown in **Figure 3** (Model CRD-3 Illustrated).

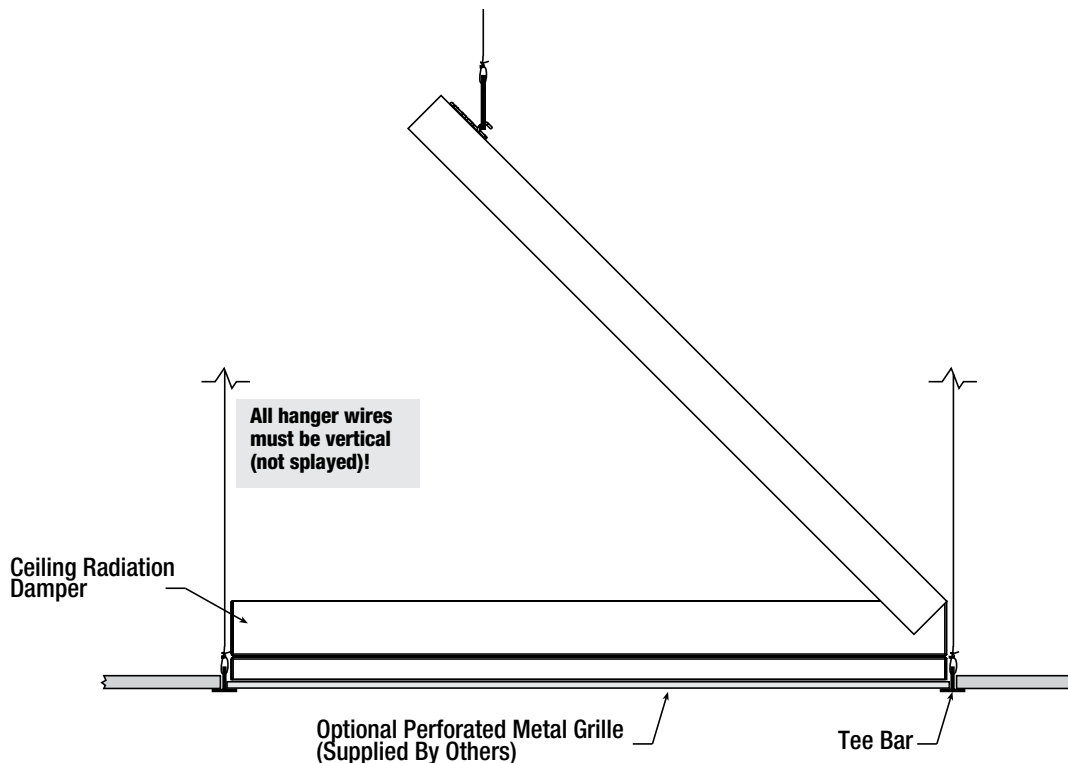

Figure 3

Dampers Supported By A Ceiling Grid System (cont.)

For Model CRD-60X

- Ceiling radiation damper is the same size as the ceiling opening and installs directly into the exposed Tee bar grid system opening.
- Damper is supported directly by the grid system and may lay on top of perforated metal (or similar) grille core material.
- Skirt material must overhang the Tee bars around perimeter of the damper.

Models CRD-60X may be installed as shown in **Figure 4**.

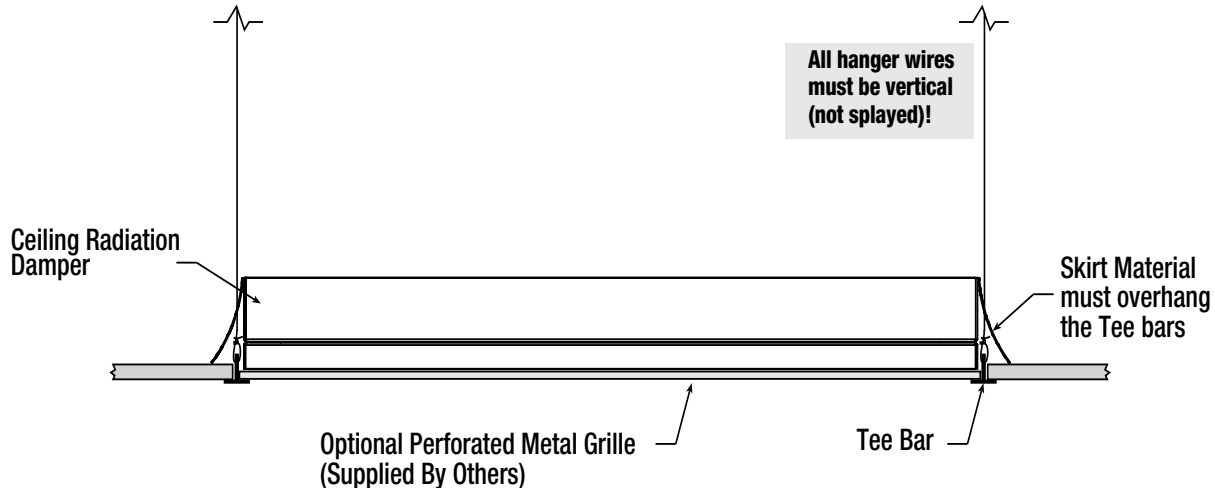

Figure 4

Dampers Supported From Ductwork Above

A Note About Support

When main ducts are supported by 16 ga. x 1½ in. steel channels (with 9/16 in. minimum flanges) located 1 in. to 3 in. from and on both sides of a steel duct drop and these channels are suspended by #12 SWG wire from structure above, the steel duct drop provides all required support for ceiling damper and

air inlet or outlet devices. Air device flange must overlap the ceiling membrane by a minimum of one inch.

Follow guidelines in *Paragraphs 3 & 4, Page 1* when preparing opening in the ceiling membrane and making connections.

Surface Mounted Air Inlet Or Outlet Devices

- Maximum size of permitted opening equals maximum size of available listed ceiling radiation dampers.
- Opening in ceiling membrane (See *Page 1, Paragraph 3*) may be up to one inch larger than the nominal size of the ceiling radiation damper (i.e. a 12 in. x 12 in. (nominal) ceiling radiation damper could have a maximum ceiling membrane opening of 13 in. x 13 in.).
- Connection of ceiling radiation damper, air device neck, and steel duct drop (see *page 1, paragraph 4*) may be satisfied in two ways:
 1. Ceiling radiation damper and air device neck may be connected directly to the duct drop (see *Detail A, Figure 5*).
 2. Ceiling radiation damper may be connected directly to the air device neck and then the duct drop connected to the damper (see *Detail B, Figure 5*).

Non-Ferrous Air Devices - Air devices that have non-ferrous frames.

Ceiling membrane openings that utilize non-ferrous devices require one of the following:

1. The steel duct drop should extend to the bottom surface of the ceiling membrane and the opening in the ceiling membrane (see *page 1, paragraph 3*) should be equal to the outside of the duct drop (see *Detail C, Figure 5*).
2. A steel angle should be attached to the bottom of the ceiling radiation damper and span the gap from the ceiling radiation damper to the bottom of the ceiling membrane. The steel angle should overlap the ceiling membrane (see *Detail D, Figure 5*).

Models CRD-1, CRD-1LP, CRD-2, and CRD-60 may be installed as shown in **Figure 5** (Model CRD-1 & CRD-1LP Illustrated).

Dampers Supported From Ductwork Above (cont.)

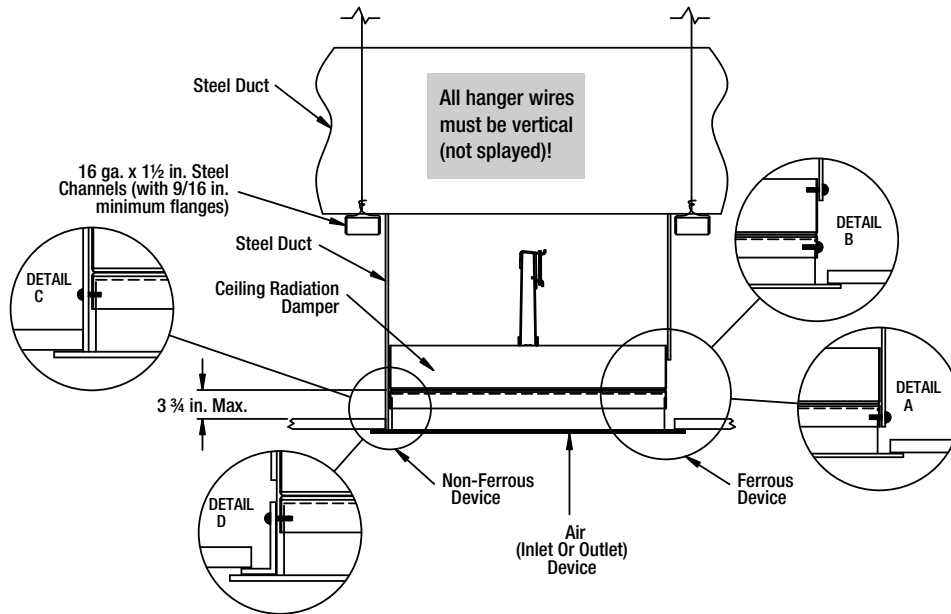

Figure 5

Recess Mounted Air Inlet Or Outlet Devices

- Opening in ceiling membrane (see page 1, paragraph 3) is more than one inch larger than nominal size of ceiling damper (i.e. if the radiation damper is 12 in. x 12 in. (nominal), the ceiling membrane opening is larger than 13 in. x 13 in.).
- Thermal blanket is required (see page 1, paragraph 5).
- Connection of ceiling radiation damper, air device neck, and steel duct drop (see page 1, paragraph 4) may be satisfied in two ways:
 1. Ceiling radiation damper and air device neck may be connected directly to the duct drop (see Detail A, Figure 6).
 2. Ceiling radiation damper may be connected directly to the air device neck and then the duct drop connected to the damper (see Detail B, Figure 6).

Models CRD-1, CRD-1LP, CRD-2, and CRD-60 may be installed as shown in **Figure 6** (Model CRD-1 & CRD-1LP illustrated).

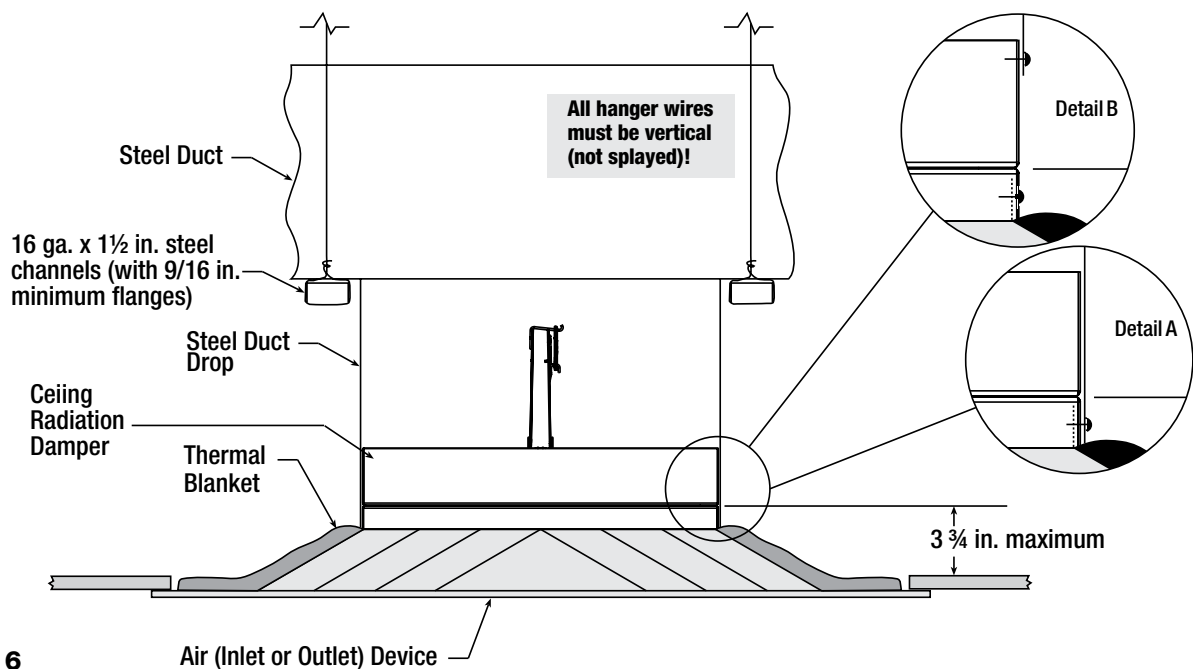

Figure 6

Dampers Supported Directly From Structure

A Note About Support

Ceiling radiation dampers and air inlet or outlet devices may also be supported directly from the structure above using one or more of the methods described in Figures 7, 8, 9, or 10. When channels are to be used as support, they must be 16 ga. x 1½ in. steel channels with 9/16 in. minimum flanges

(2 required per damper on opposite sides). Air device flange must overlap the ceiling membrane by a minimum of one inch.

Follow guidelines in *Paragraphs 3 & 4, Page 1* when preparing opening in the ceiling membrane and making connections.

Ducted Surface Mounted Air Inlet Or Outlet Devices

- Maximum size of permitted opening equals maximum size of available listed ceiling radiation dampers.
- Opening in ceiling membrane (See *Page 1, Paragraph 3*) may be up to one inch larger than the nominal size of the ceiling radiation damper (i.e. a 12 in. x 12 in. (nominal) ceiling radiation damper could have a maximum ceiling membrane opening of 13 in. x 13 in.).
- Steel channel is connected directly to ceiling radiation damper (See *Page 1, Paragraph 4*).
- Connection of ceiling radiation damper, air device neck, and steel duct drop (See *Page 1, Paragraph 4*) may be satisfied in two ways:
 1. Ceiling radiation damper and air device neck may be connected directly to the duct drop (See *Detail A, Figure 7*).
 2. Ceiling radiation damper may be connected directly to the air device neck and then the duct drop connected to the damper (See *Detail B, Figure 7*).

Non-Ferrous Air Devices - Air devices that have non-ferrous frames.

Ceiling membrane openings that utilize non-ferrous devices require one of the following:

1. The steel duct drop should extend to the bottom surface of the ceiling membrane and the opening in the ceiling membrane (see page 1, paragraph 3) should be equal to the outside of the duct drop (See *Detail C, Figure 7*). Models CRD-1, CRD-1LP, CRD-2, and CRD-60 may be installed as shown in **Figure 7** (Model CRD-1 & CRD-1LP Illustrated).
2. A steel angle should be attached to the bottom of the of the ceiling radiation damper and span the gap from the ceiling radiation damper to the bottom of the ceiling membrane. The steel angle should overlap the ceiling membrane (See *Detail D, Figure 7*).

Models CRD-1, CRD-1LP, CRD-2, and CRD-60 may be installed as shown in **Figure 7** (Model CRD-1 & CRD-1LP Illustrated).

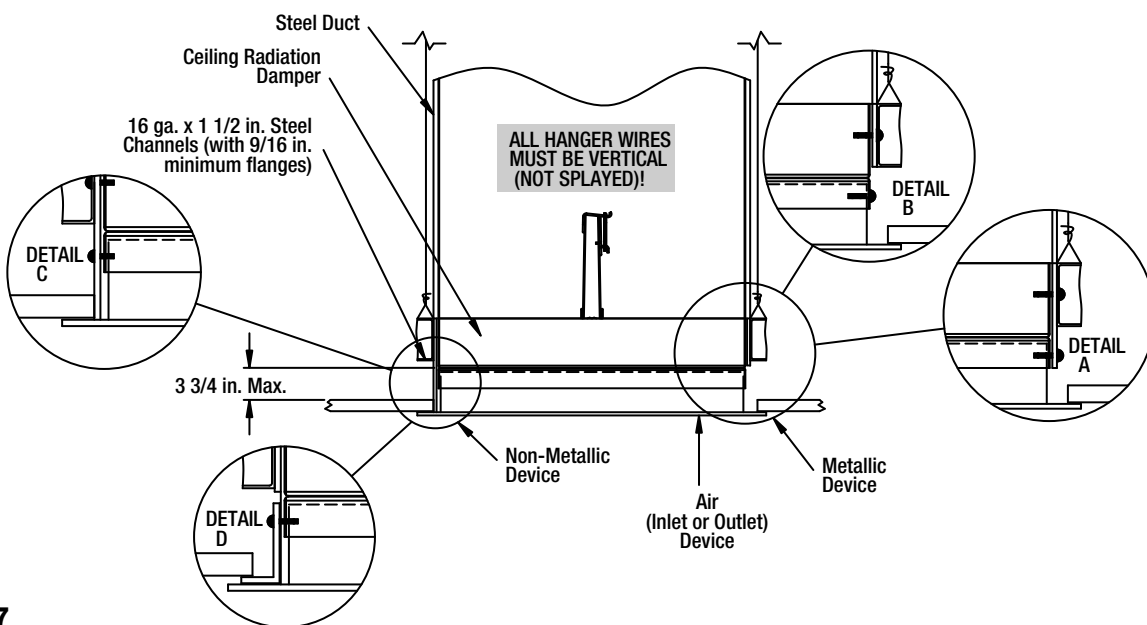

Figure 7

Dampers Supported Directly From Structure (cont.)

Ducted Recess Mounted Air Inlet Or Outlet Devices

- Opening in ceiling membrane is more than one inch larger than nominal size of ceiling damper (i.e. if the ceiling radiation damper is 12 in. x 12 in. (nominal), the ceiling membrane opening is larger than 13 in. x 13 in.).
- Maximum size of opening is 24 in. x 24 in. (576 sq. in.).
- Thermal blanket is required. (See Page 1, Paragraph 5).
- Connection of ceiling radiation damper, air device neck, and steel duct drop (See Page 1, Paragraph 4) may be satisfied in two ways:
 1. Ceiling radiation damper and air device neck may be connected directly to the duct drop (See Detail A, Figure 8).
 2. Ceiling radiation damper may be connected directly to the air device neck and then the duct drop connected to the damper (See Detail B, Figure 8).

Models CRD-1, CRD-1LP, CRD-2, and CRD-60 may be installed as shown in **Figure 8** (Model CRD-1 & CRD-1LP Illustrated).

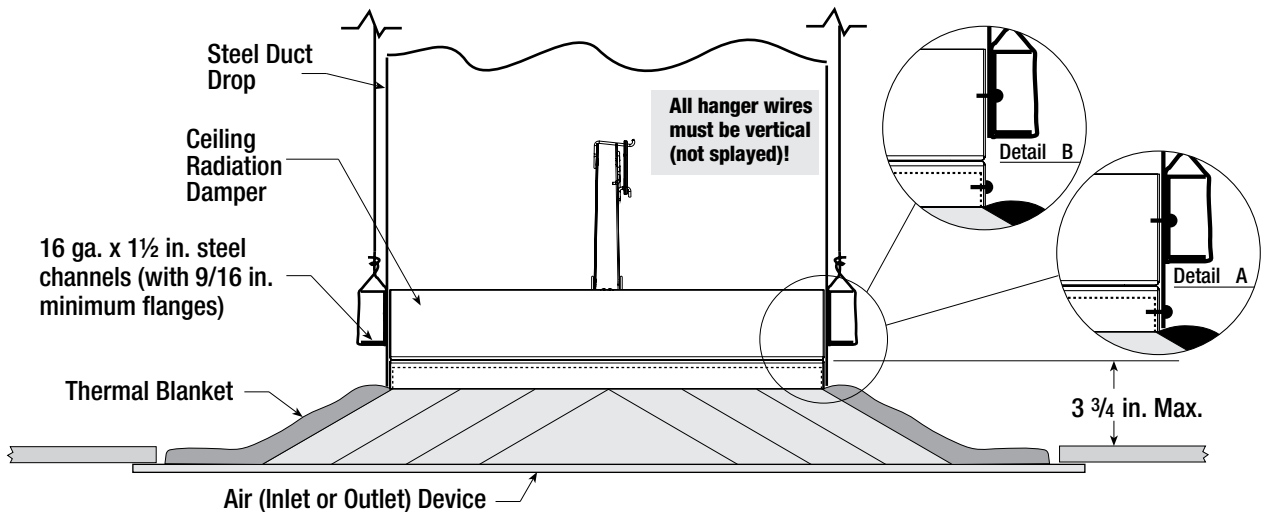

Figure 8

Unducted Surface Mounted Air Inlet Or Outlet Devices

- Maximum size of permitted opening equals maximum size of available listed ceiling radiation dampers.
- Opening in ceiling membrane may be up to one inch larger than the nominal size of the ceiling radiation damper (i.e. a 12 in. x 12 in. (nominal) ceiling radiation damper could have a maximum ceiling membrane opening of 13 in. x 13 in.).
- Connection of ceiling radiation damper and air device neck (See Page 1, Paragraph 4) may be satisfied in three ways:
 1. Ceiling radiation damper may be connected directly to the air device neck and supported by steel channel (See Detail A, Figure 9).
 2. Ceiling radiation damper may be connected directly to the air device neck and supported by hanger straps (See Detail B, Figure 9).
 3. Ceiling radiation damper may be connected directly to the air device neck and supported by direct suspension with wires looped through holes in the damper frame before tying (See Detail C, Figure 9).

Non-Ferrous Air Devices - Air devices that have non-ferrous frames.

Ceiling membrane openings that utilize non-ferrous devices require one of the following:

1. A steel extension should extend from the ceiling radiation damper to the bottom surface of the ceiling membrane and the opening in the ceiling membrane (see page 1, paragraph 3) should be equal to the outside of the steel extension (see Detail D, Figure 9).
2. A steel angle should be attached to the bottom of the ceiling radiation damper and span the gap from the ceiling radiation damper to the bottom of the ceiling membrane. The steel angle should overlap the ceiling membrane (see Detail E, Figure 9).

Models CRD-1, CRD-1LP, CRD-2, and CRD-60 may be installed as shown in **Figure 9** (Model CRD-1 CRD-1LP Illustrated).

Dampers Supported Directly From Structure (cont.)

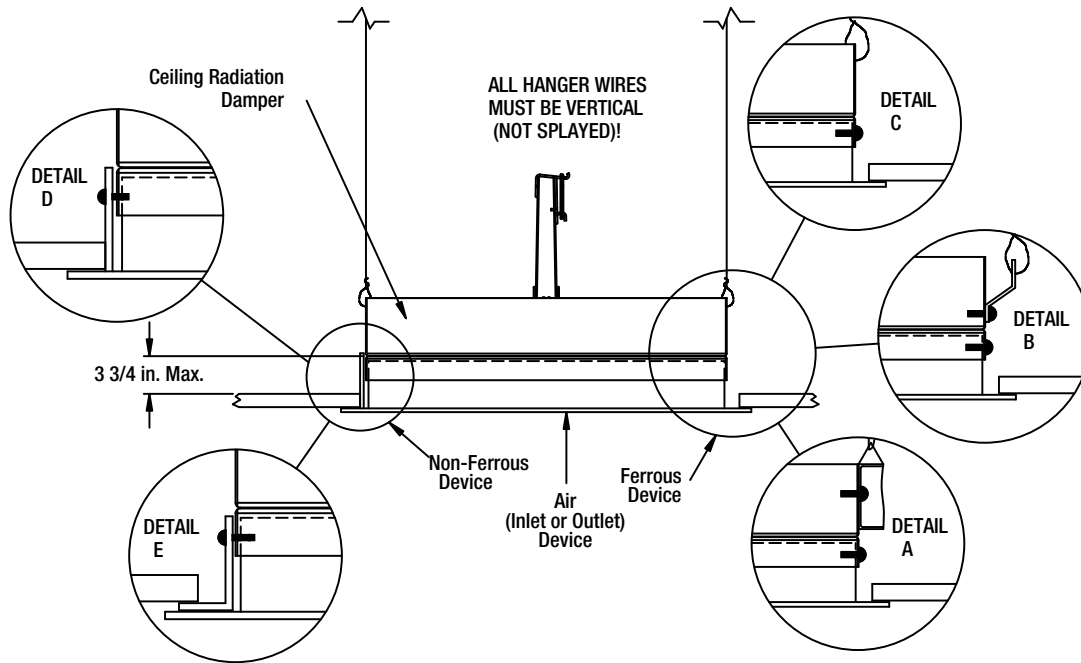

Figure 9

Unducted Recess Mounted Air Inlet Or Outlet Devices

- Opening in ceiling membrane is more than one inch larger than nominal size of ceiling damper (i.e. if the ceiling radiation damper is 12 in. x 12 in. (nominal), the ceiling membrane opening is larger than 13 in. x 13 in.).
- Maximum size of opening is 24 in. x 24 in. (576 sq. in.).
- Thermal blanket is required. (See Page 1, Paragraph 5).
- Connection of ceiling radiation damper and air device neck may be satisfied in three ways:
 1. Ceiling radiation damper may be connected directly to the air device neck and supported by steel channel (See Detail A, Figure 10).
 2. Ceiling radiation damper may be connected directly to the air device neck and supported by hanger straps (See Detail B, Figure 10).
 3. Ceiling radiation damper may be connected directly to the air device neck and supported by direct suspension with wires looped through holes in the damper frame before tying (See Detail C, Figure 10).

Models CRD-1, CRD-1LP, CRD-2, and CRD-60 may be installed as shown in **Figure 10** (Model CRD-1 & CRD-1LP Illustrated).

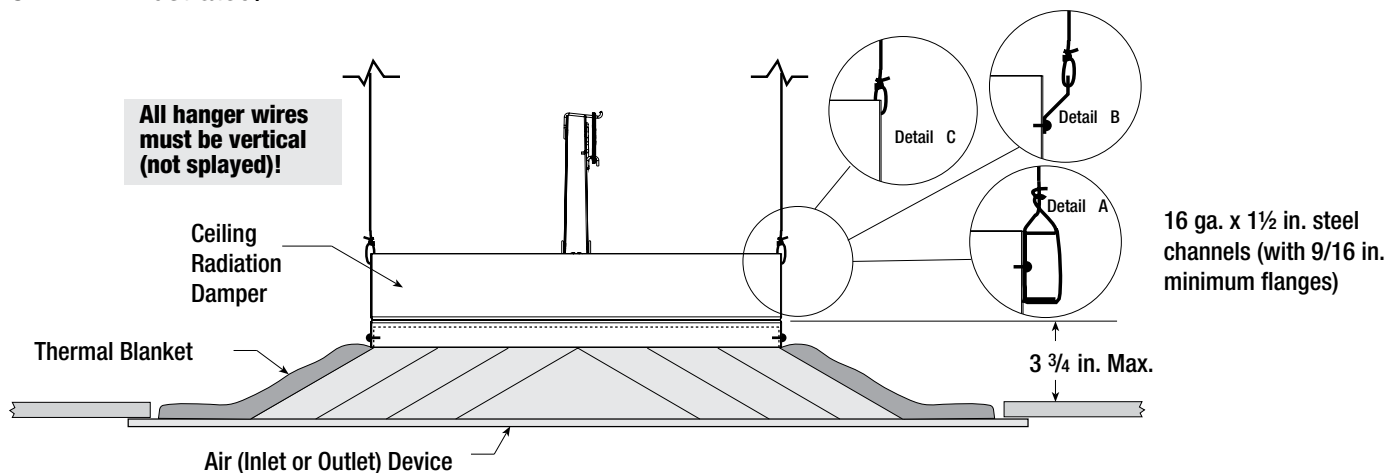

Figure 10

