

Installation, Operation and Maintenance Instructions

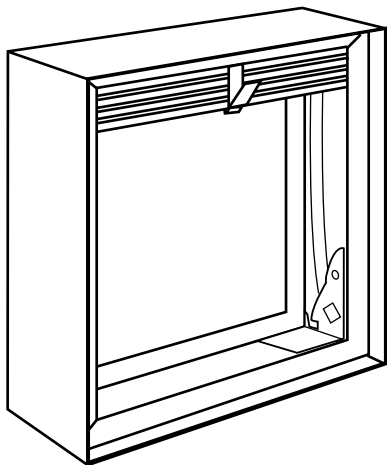

FD, DFD, SSFD, & KFD models are intended for installation in accordance with fire damper requirements established by:

National Fire Protection Association

NFPA Standard 80, 90A, & 101

IBC International Building Code

CSFM California State Fire Marshal

Fire Damper Listing (#3225-0981:102)

New York City (BSA/MEA listing #260-91-M)

“UL CLASSIFIED (see complete marking on product)”
“UL CLASSIFIED to Canadian safety standards (see complete marking on product)”

UL Standard 555 (Listing #R13317)

SAFETY WARNING:

Improper installation, adjustment, alteration, service or maintenance can cause property damage, injury or death. Read the installation, operating, and maintenance instructions thoroughly before installing or servicing this equipment.

WARRANTY

Greenheck warrants this equipment to be free from defects in material and workmanship for a period of one year from the shipment date. Any units or parts which prove to be defective during the warranty period will be repaired or replaced at our option. Greenheck shall not be liable for damages resulting from misapplication or misuse of its products. Greenheck will not be responsible for any installation or removal costs. Greenheck will not be responsible for any service work or backcharges without prior written authorization.

RECEIVING AND HANDLING

Upon receiving dampers, check for both obvious and hidden damage. If damage is found, record all necessary information on the bill of lading and file a claim with the final carrier. Check to be sure that all parts of the shipment, including accessories, are accounted for.

Dampers must be kept dry and clean. Indoor storage and protection from dirt, dust and the weather is highly recommended. Do not store at temperatures in excess of 100°F (38°C).

Installation Supplements

Refer to the appropriate Greenheck installation supplements for special requirements:

- Close Indicator Switch
- Concrete Floor with Steel Deck
- Drive Slip Breakaway Connection
- Fire Resistant Ventilated Duct Assembly
- Firestop Material
- Greenheck Test Switch
- Grille Installation
- Metal Stud in Shaftwall
- Quick Connect Breakaway Connections
- Sealant Supplement
- Single Side Retaining Angle
- Single 3-Sided Retaining Angle - Vertical Mount
- Sleeve Extension
- Support Mullions

Note: Refer to Greenheck IOM, Part #461335, for CFSD models to be installed in corridor ceiling applications.

These instructions apply to 1½ and 3 hour rated fire dampers mounted (blades must be horizontal) in masonry, block or stud walls and concrete floors. Specific requirements in these instructions are mandatory. These instructions meet the requirements of UL 555. Installation shall comply with the requirements of NFPA 90A Standard for the Installation of Air Conditioning and Ventilating Systems. UL listing R13317, California State Fire Marshal listings 3225-0981:102, and New York City BSA/MEA listing 260-91-M apply to these dampers. Note: Fire dampers are manufactured and labelled for either vertical or horizontal installation. The dampers must be installed in accordance with the labelling.

Due to continuing research, Greenheck reserves the right to change specifications without notice.

This manual is the property of the owner, and is required for future maintenance. Please leave it with the owner when the job is complete.

Table of Contents

Pre-Installation Guidelines.....	2
Installation.....	2-8
• Clearances Required Between Fire Damper Sleeves and Wall/Floor Openings.....	2
• Sleeve Length and Wall Thickness	4
• Duct to Sleeve Connections.....	3-4
• Securing the Damper/Sleeve Assembly to Wall and Floor Openings.....	4
• Installing Multiple Damper Section Assemblies	5
• Recommended Preparation of Openings in Wood and Metal Stud Walls.....	6-7
• Breakaway Connections	7

Pre-Installation Guidelines

The basic intent of a proper installation is to secure the fire damper in, not to, the opening in such a manner as to prevent distortion and disruption of damper operation. This is accomplished by allowing the fire damper in rated separation openings to expand and for the connecting duct to separate in the event of the collapse of the hanging system. The following items will aid in completing the damper installation in a timely and effective manner.

- 1) Check the schedules for proper damper locations within the building. Visually inspect the damper for damage and verify that the fusible link is in place or has not activated. Never install a fire damper without the proper UL approved fusible link in place. If damper is furnished with fusible link, visually inspect the link to verify its not missing or broken. Replace link as necessary.
- 2) Lift or handle damper using sleeve or frame. Do not lift damper using blades.
- 3) Damper has label on outside of sleeve indicating a 'No Screw' area. Do not install screws into this area as screws may interfere with unexposed blade linkage and prevent damper blades from opening and/or closing.
- 4) Damper has label indicating position of damper and sleeve assembly in the wall. Install accordingly to comply with manufacturer's appropriate UL Classification file number.
- 5) Damper must be installed into duct or opening square and free of twist or other misalignment. Damper must not be squeezed or stretched into duct or opening. Out of square, racked, twisted or misaligned installations can cause excessive leakage and/or torque requirements to exceed damper/actuator design.
- 6) Damper must be kept clean and protected from dirt, dust and other foreign materials prior to and after installation. Examples of such foreign materials include but are not limited to:
 - a) Mortar dust
 - b) Drywall dust
 - c) Firesafing materials
 - d) Wall texture
 - e) Paint overspray
- 7) Damper should be sufficiently covered as to prevent overspray if wall texturing or spray painting will be performed within 5 feet of the damper. Excessive dirt or foreign material deposits on damper can cause excessive leakage and/or torque requirements to exceed damper/actuator design.
- 8) Caulking is not necessary, nor is it allowed, between the damper sleeve and the wall or floor opening (annular space). However, caulking may be applied to the retaining angles.
- 9) ACCESS: Suitable access (such that fusible links can be maintained, etc.) must be provided for damper inspection and servicing. Where it is not possible to achieve sufficient size access, it will be necessary to install a removable section of duct. (Refer to NFPA 90A).
- 10) The Code Authority Having Jurisdiction (AHJ) must evaluate and provide approval of final installation where variations to these instructions are necessary.

1. CLEARANCES REQUIRED BETWEEN FIRE DAMPER SLEEVES AND WALL/FLOOR OPENINGS

Fire damper and sleeve assemblies expand during periods of intense heat. Therefore it is essential that openings in walls or floors be larger than the fire damper and sleeve assembly to allow for this expansion. Minimum clearances required between the outside of fire damper sleeve assemblies and wall/floor openings are:

- Galvanized steel fire dampers and sleeves: 1/8 in. (3mm) per foot of damper width and 1/8 in. (3mm) per foot height with a minimum clearance of 1/4 in. (6mm) *Recommended clearances, for width and/or height dimensions of:*
 - 1) 48 in. (1219mm) or less: 1/2 in. (13mm) clearance
 - 2) More than 48 in. (1219mm) and 96 in. (2438mm) or less: 1 in. (25mm) clearance
 - 3) More than 96 in. (2438mm): 1 1/2 in. (38mm) clearance
 - Stainless steel fire dampers and stainless steel or galvanized sleeves: 3/16 in. (4.8mm) per foot of damper width and height with a minimum clearance of 1/4 in. (6mm), maximum of 2 in. (51mm). *Recommended clearances, for width and/or height dimensions of:*
 - 1) 48 in. (1219mm) or less: 3/4 in. (19mm) clearance
 - 2) More than 48 in. (1219mm) and 96 in. (2438mm) or less: 1 1/2 in. (38mm) clearance
 - 3) More than 96 in. (2438mm): 2 in. (51mm) clearance
- These are total clearances (ignoring fastener heads) and do not need to be equally spaced around the damper. Refer to Section 4 and Figure 6 for additional installation considerations.

Example: A 12 in. x 12 in. (305mm x 305mm) damper would require a minimum clearance of 1/4 in. (6mm) on width and 1/4 in. (6mm) on height

A 48 in. x 12 in. (1219mm x 305mm) damper would require a minimum clearance of 1/2 in. (13mm) on width and 1/4 in. (6mm) on height.

2. GAUGES AND LENGTHS OF FIRE DAMPER SLEEVES

All fire dampers must be installed in a steel sleeve of the required gauge and length. See **Table 1** for required minimum sleeve gauges. Maximum sleeve thickness is 10 gauge (3.5mm). Sleeve inside dimensions must equal damper outside dimensions.

Sleeves shall extend a maximum of 6 in. (152mm) beyond the wall or floor opening on each side (see **Figure 1**). When an access door is incorporated as a part of sleeve, the sleeve may extend a maximum of 16 in. (406mm) beyond the wall or floor opening on the access door side.

Sleeve Gauge	Duct Dimension	Type of Duct to Sleeve Connection Permitted
14 ga. (0.075 in.) - 10 ga. (0.138 in.) [2mm - 3.5mm]	All duct sizes	Rigid or Breakaway
16 ga. (0.060 in.) [1.5mm]	36 in. (914mm) max. width 24 in. (610mm) max. width 24 in. (610mm) diameter	Rigid or Breakaway
16 ga. (0.060 in.) [1.5mm]	All duct sizes	Breakaway only
18 ga. (0.048 in.) [1.2mm]	85 in. (2159mm) wide and over	
20 ga. (0.036 in.) [0.9mm]	55 in. - 84 in. wide (1397mm - 2134mm)	
22 ga. (.030 in.) [0.76mm]	31 in. - 54 in. wide (787mm - 1372mm)	
24 ga. (0.024) [0.6mm]	13 in. - 30 in. wide (330mm - 762mm)	
26 ga. (0.018 in.) [0.46mm]	12 in. wide and under (305mm)	
Sleeve thickness must not be less than the gauge of the connecting duct. UL Standard 555 requires all ducts to terminate at fire damper sleeves.		

Table 1: Minimum sleeve thickness for fire dampers.

Vertical mount without factory mounted sleeve

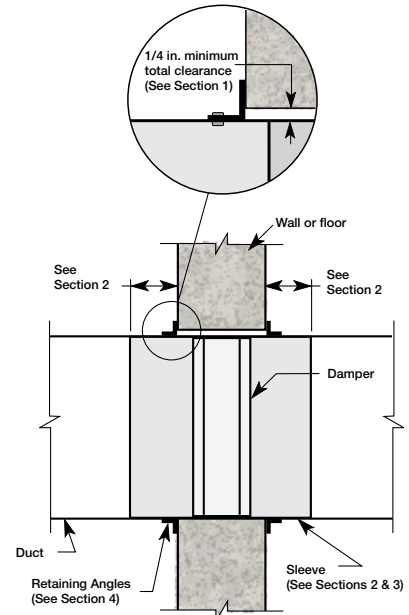

Type A

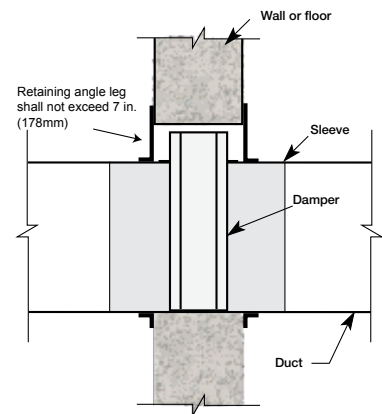

Type B

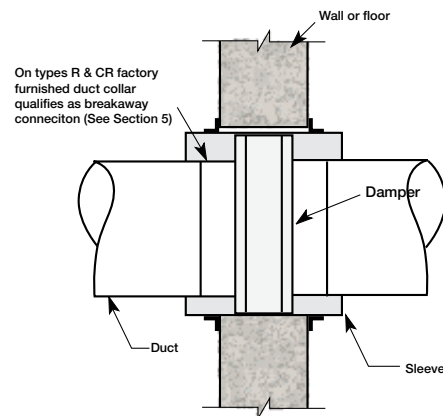

Type C, CO, CR & R

When dampers installed vertically, the blade stack must be on the top..

Figure 1

Horizontal mount without factory mounted sleeve

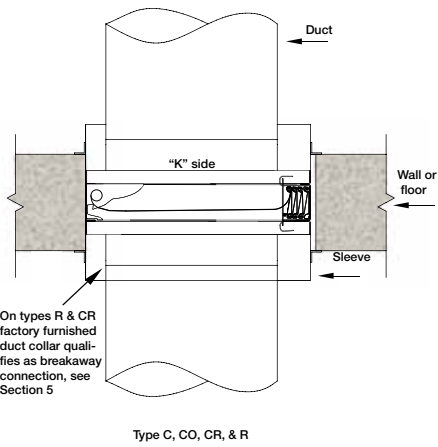
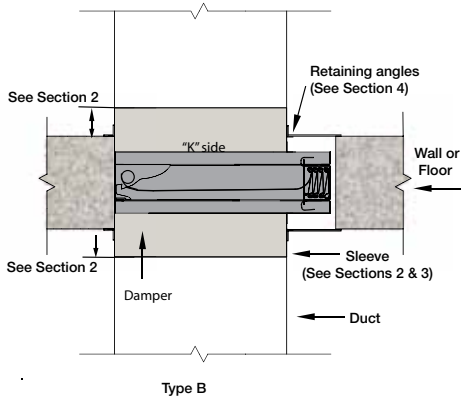
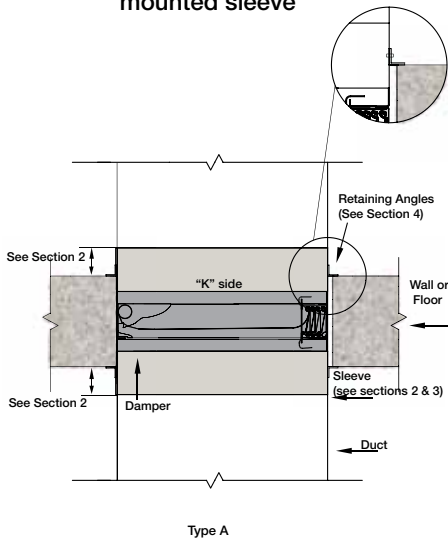

When dampers installed horizontally, the ramp must be positioned up as shown in above drawings.

Vertical mount with factory mounted sleeve

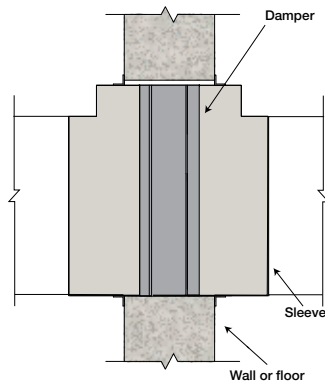
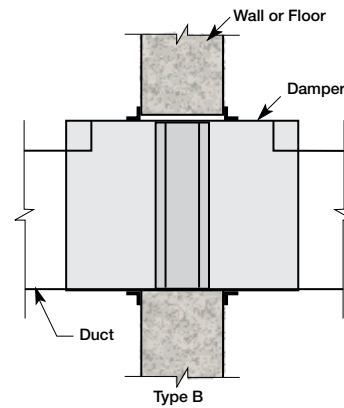
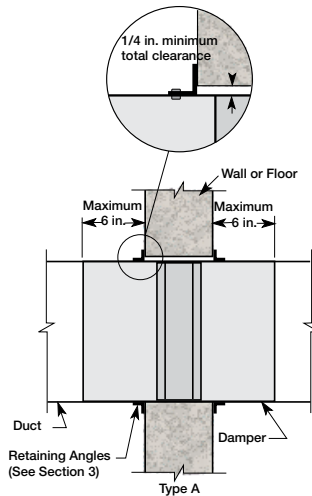

On types R, CO & CR factory furnished duct collar qualifies as breakaway connection.

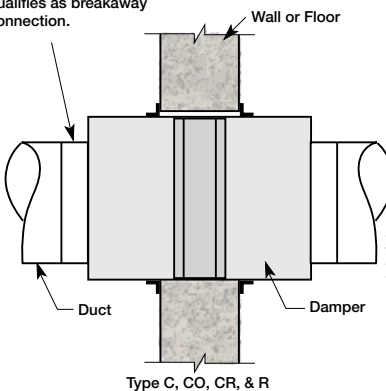

When dampers installed vertically, the blade stack must be on the top.

Horizontal mount with factory mounted sleeve

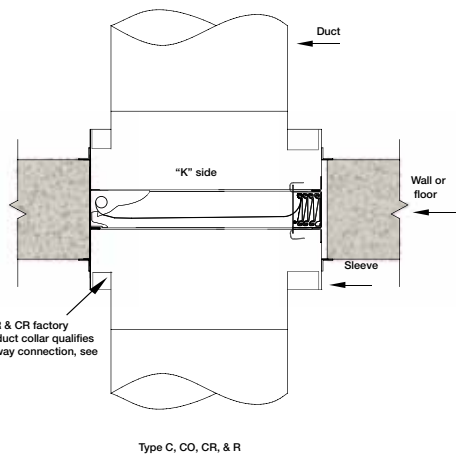
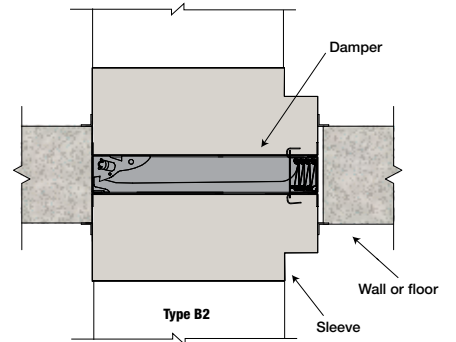
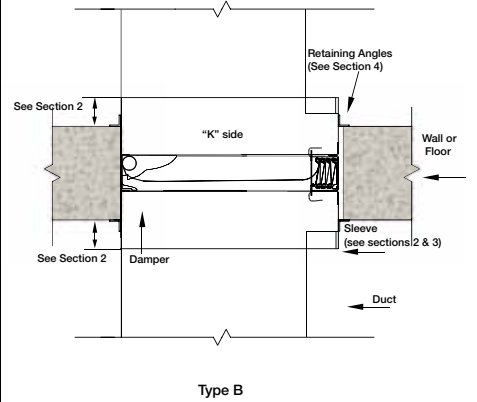
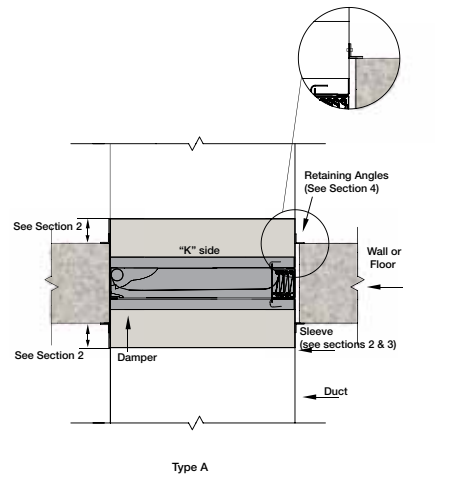

When dampers installed horizontally, the ramp must be positioned up as shown in above drawings.

Figure 1

3. ATTACHING FIRE DAMPERS TO SLEEVES

Fire dampers must be attached to sleeves as shown in **Figure 3**. All four sides of the damper frame must be attached to the sleeve with one row of attachments on each side of the blade channel. Attachments must be spaced a maximum of 6 in. (152mm) on centers and a maximum of 2 in. (51mm) from corners. A minimum of 4 attachments (2 on each side of the blade channel) per side (16 per damper) are required. One of the methods of attachment shown below must be used.

- tack or spot welds
- #10 sheet metal screws
- 1/4 in. (6mm) bolts and nuts
- 3/16 in. (4.7mm) steel pop rivets

4. SECURING FIRE DAMPER AND SLEEVES TO WALL AND FLOOR OPENINGS.

The fire damper must be installed such that the centerline of the blades are mounted in the plane of the wall or floor.

Fire damper and sleeve assemblies must be installed in wall and floor openings using retaining angles on each side of the wall or floor as described below:

- Retaining angles for 1½ hour rated dampers with a width and height 48 in. (1219mm) or less must be a minimum of 20 ga. (1mm). Retaining angles for all 3 hour rated dampers and all dampers with a width or height greater than 48 in. (1219mm) must be a minimum of 16 gauge (1.5mm). The leg of the retaining angle on the damper sleeve shall be a minimum of 1¼ in. (32mm). The leg of the retaining angle on the wall/floor shall be long enough to cover the annular space and overlap the wall/floor by a minimum of 1 in. (25mm). (See **Figure 4**). Retaining angle legs may be reversed with leg of retaining angle with annular space of opening so angle and sleeve is flush against barrier.
- Retaining angles must be attached to the sleeve using the procedures and methods described in Section 3. The angles must be attached to all 4 sides of the sleeve with butt joints at each corner. A minimum of two attachments are required on each side, top and bottom. The angles need not be attached to each other at the corners.
- Retaining angles should not be fastened to the wall/floor material. The angles should only sandwich the wall/floor and allow for damper/sleeve expansion during periods of intense heat.

For single retaining angle applications, see Single Side Retaining Angle Supplement (#474015).

No Connecting Duct or Transfer Opening

Openings where duct does not attach on either side will not require a breakaway connection. Transfer openings are typical of a non-ducted installation (see **Figure 2**).

- Sleeve may end flush with the rated wall/floor on both sides
- Refer to Section 4 for securing retaining angles to sleeves.

5. CONNECTING DUCTS TO FIRE DAMPER SLEEVE

Any duct connection other than breakaway is considered rigid. The connections shown on this page are considered breakaway. Factory furnished duct collars on type R and CR fire dampers are also considered breakaway (see **Figure 1**).

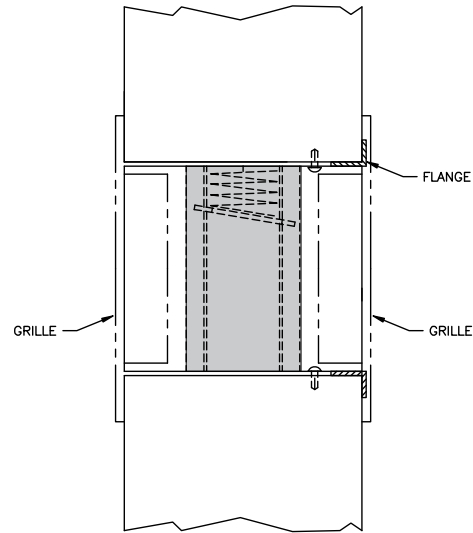

Figure 2 Transfer opening or no connecting duct

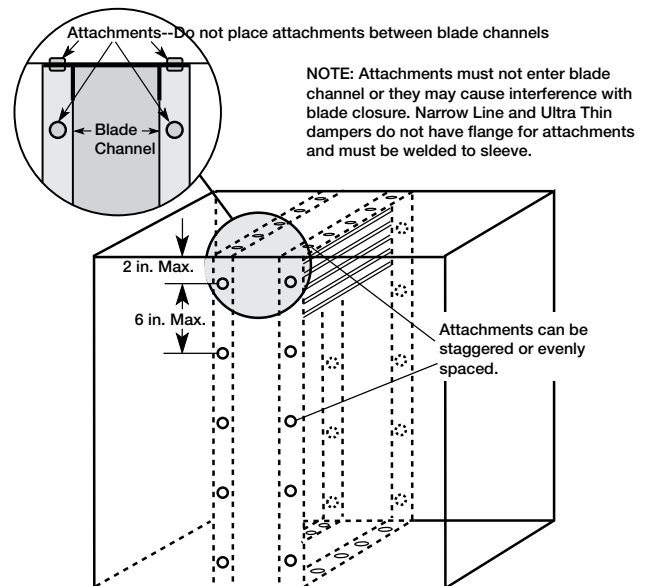

Figure 3: Field attachment of fire dampers to sleeves.

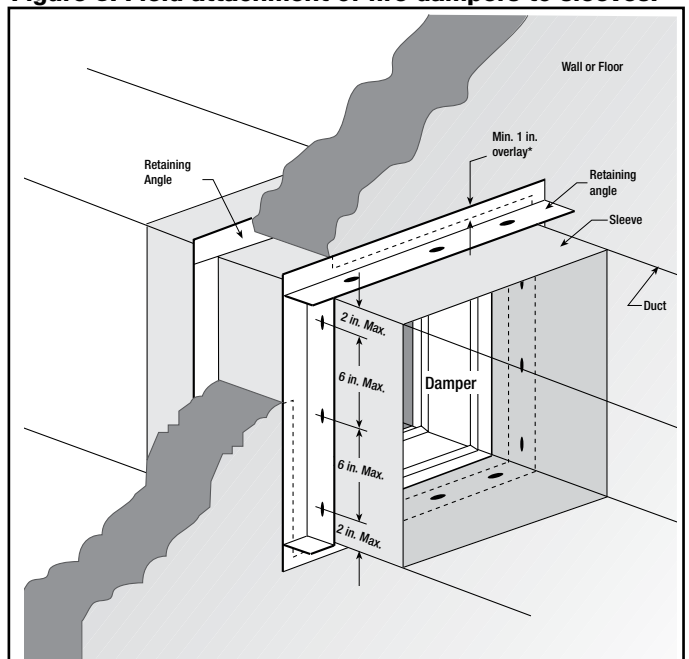

Figure 4: Retaining angle installation.

6. MULTIPLE SECTION FIRE DAMPERS

When multiple sections are shipped unassembled, installer shall fasten dampers together as described in Section 3. **Table 2** shows maximum sizes for multiple section dampers. Dampers that are two or more sections tall must be factory assembled.

Damper Model	Maximum Damper Single Section Sizes*	Maximum Overall Size for Multi-Section Dampers*
FD-110 (H or V), FD-300/350 (V) FD-310/355 (V)	48 X 48 (1219mm x 1219mm)	-
FD-150/155 (V)	48 X 48 (1219mm x 1219mm)	-
KFD-110 (H or V)	36 X 16 (914mm x 406mm)	96 X 48 (2438mm x 1219mm)
FD-150/155 (H or V), SSFD-150/155 (V)	48 X 48 (1219mm x 1219mm)	96 X 48 (2438mm x 1219mm) or 120 X 40 (3048mm x 1016mm)
KFD-150	36 X 16 (914mm x 406mm)	96 X 48 (2438mm x 1219mm) or 120 X 40 (3048mm x 1016mm)
SSFD-150/155 (H) SSFD-355 (V)	36 X 36 (914mm x 914mm)	-
FD-350/355 (H)	40 X 40 (1016mm x 1016mm)	80 X 40 (2032mm x 1016mm)
KFD-350 (H)	36 X 16 (914mm x 406mm)	80 X 40 (2032mm x 1016mm)
KFD-310/350 (V) SSKFD-350/355	36 X 16 (914mm x 406mm)	-
FD-150/155 (V)	37 X 37 (940mm x 940mm)	74 X 74 (1880mm x 1880mm)
FD-100 (V), SSFD-350 (V)	48 X 48 (1219mm x 1219mm)	-
DFD-150/155 (V)	24 X 24 (610mm x 610mm)	72 X 48 (1829mm x 1219mm)
DFD-150/155 (V)	30 X 30 (762mm x 762mm)	60 X 60 (1524mm x 1524mm)
DFD-110 (V) DFD-310/350/355 (V) DFD-150/155 (V)	36 X 36 (914mm x 914mm)	-
DFD-110 (H), SSDFD-X5X (V)	30 X 30 (762mm x 762mm)	-
DFD-350/355 (V)	24 X 24 (610mm x 610mm)	48 X 48 (1219mm x 1219mm)
DFD-150/155 (H), DFD-350/355 (H)	30 X 30 (762mm x 762mm)	48 X 36 (1219mm x 914mm)
DFD-150/155,(H), DFD-350/355 (H)	24 X 18 (610mm x 457mm)	48 X 36 (1219mm x 914mm)

Note: V=Vertical Mount and H=Horizontal Mount. All dimensions shown are in inches.
* Sizes listed is the damper size not transition size.

Table 2: Maximum section sizes and overall sizes for multiple section dampers.

DUCT-SLEEVE CONNECTIONS

Traditional Breakaway Style Transverse Joints

Transverse joints illustrated in **Figure 5** have always been approved as breakaway connections. SMACNA testing has also approved the following variations as breakaway connections.

- The breakaway connections shown to the right can be applied with maximum of (2) #10 sheet metal screws on each side and on the bottom located in the center of the slip pocket and penetrating both sides of the slip pocket.
- Transverse joints illustrated can be applied as top and bottom joints with Drive Slip - side joints in duct heights up to 20 inches (508mm).

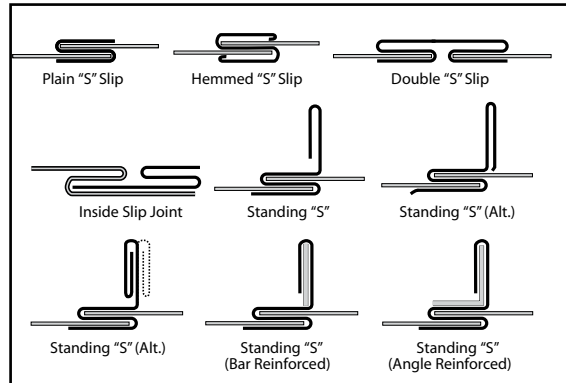

Figure 5: Traditional breakaway style transverse joints.

Round and Oval Duct Breakaway Connections

Round ducts connected to factory supplied Type R or CR damper collars may use #10 sheet metal screws as follows:

- Ducts 22 in. (559mm) wide (or dia.) and smaller may use 3 screws.
- Ducts larger than 22 in. (559mm) wide (or dia.) may use 5 screws.

NOTE: All breakaway connections described may have duct sealant applied, PA2084T duct sealant adhesive manufactured by Precision or DP1010 water base duct sealant by Design Polymetrics, Grey Pookie or Ductmate PROseal® in accordance with SMACNA recommendations.

Manufactured Flanged System Breakaway Connections

Flanged connection systems manufactured by Ductmate, Ward, and Nexus are approved as breakaway connections when installed as illustrated in **Figure 6**.

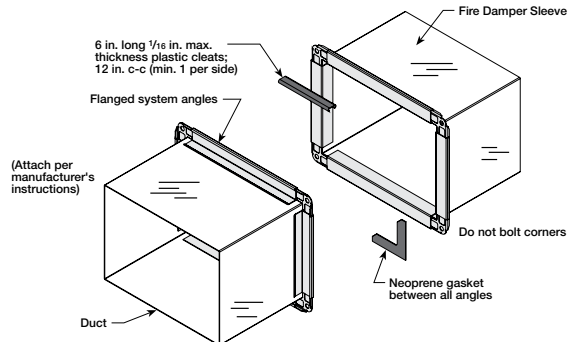

Figure 6: Detail of manufactured flanged system breakaway connections.

Proprietary Flange System Breakaway Connections

(TDC by Lockformer, TDF by Engle)

TDC and TDF systems are approved as breakaway connections when installed as described in the SMACNA Duct Construction Standards. Standard 6 in. (152mm) metal clip may be used with spacing as shown in **Figure 7**. Three-eighths in. (9.5mm) metal bolts and nuts may be used to fasten together corner pieces.

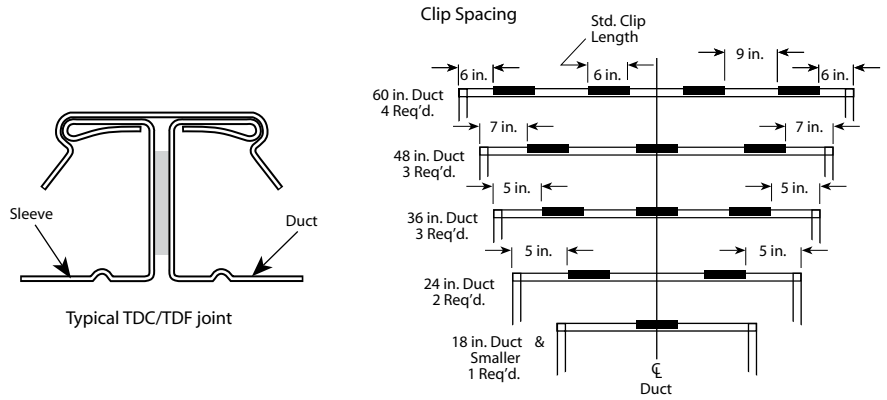

Figure 7: Detail of proprietary flanged system breakaway connections.

Recommended Preparation of Openings in Wood and Metal Stud Walls

- Frame wall openings as shown in **Figure 8**.
- Double vertical studs are not required for openings 36 in. x 36 in. (914mm x 914mm) or smaller.
- Double horizontal studs may be used to frame opening.
- Gypsum wall board must be fastened 12 in. (305mm) on center to all stud and runner flanges surrounding opening (see **Figure 11**).
- All construction and fasteners must meet the requirements of the appropriate wall design. (See UL Fire Resistance Directory)

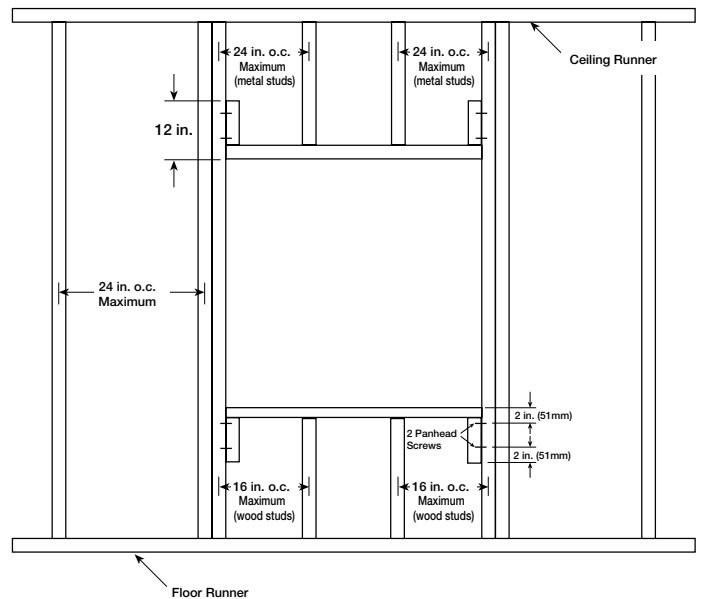

Figure 8: Preparation detail for opening in stud wall.

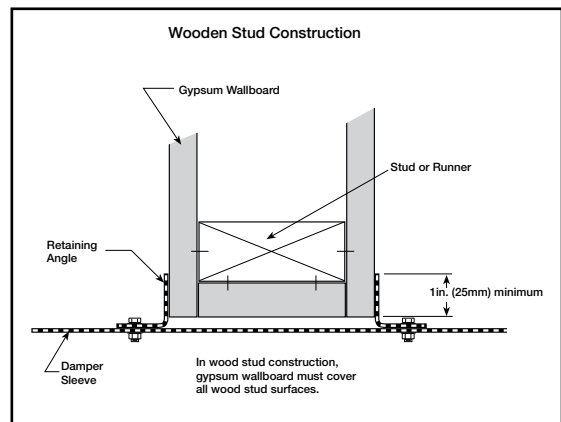
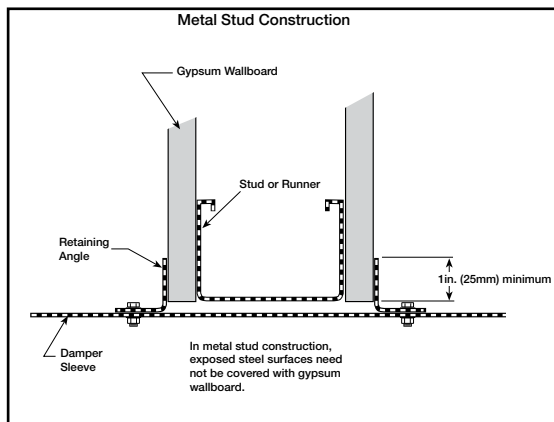

Figure 9: Detail of retaining angles and gypsum board application for metal and wooden stud construction.



Copyright © 2011 Greenheck Fan Corporation
452763 FD/DFD Rev. 14 Sept 2011

P.O. Box 410 • Schofield, WI 54476-0410 • 715.359.6171 • greenheck.com