

These instructions apply to the field installation of end switch kits on Greenheck model WD Backdraft Dampers. These end switch kits can be used in conjunction with MP-100, MP-200, and MP-300 Series actuators.

End switches are typically wired to a fan and/or to a light serving as an open/not open indicator. When the damper is powered open, one of the damper blades makes contact with the spring rod of the end switch which in turn makes a connection allowing power to flow to the fan and/or light. This set up would be used when it is desirable to ensure that the damper is fully open before the fan starts.

Instructions:

1. Position end switch such that the back side of damper blade trips the spring rod.
2. Mount end switch bracket to damper frame or ductwork using #10 x 1/2 in. self-drilling sheet metal screws

Part #	Qty.	Description
1	1	End switch mounting bracket
2	1	End switch UL/CSA Rating L67 15 Amps: 125, 250, or 480 VAC 0.25 Amps: 250 VDC 0.50 Amps: 125 VDC
3	2	#6-32NC x 1 1/2 in. machine screws with nuts (packaged in end switch housing)
4	2	#10 x 1/2 in. self-drilling sheet metal screws

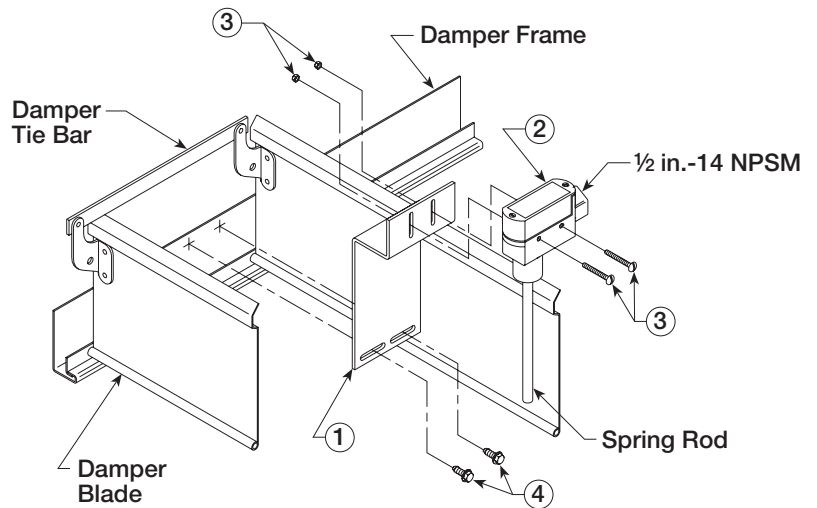
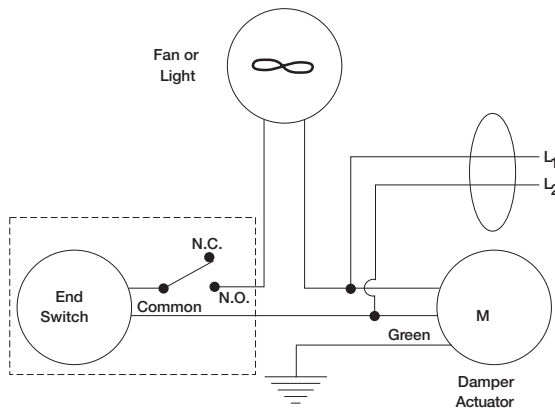
**End Switch Installation On
WD-100 Series Dampers**

Note: Some actuators are multi-tap, use correct connections per actuator wiring diagram.

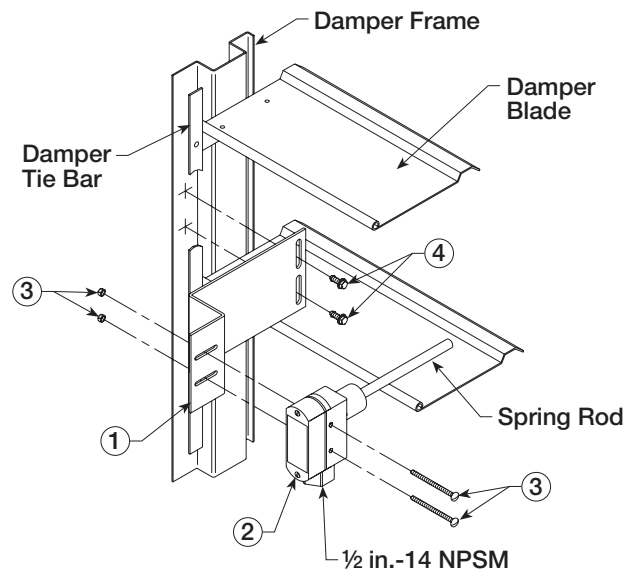
Wiring Illustration

**End Switch Installation On
WD-200 & 300 Series Dampers**