

Energy Recovery Lab Exhaust Systems

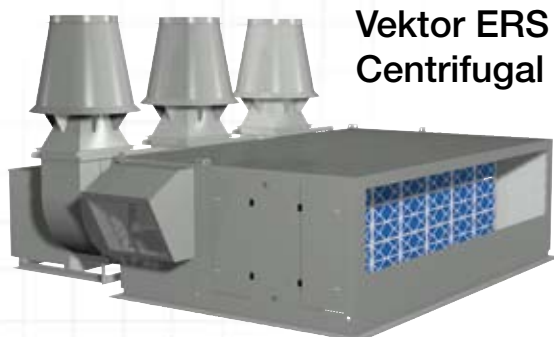

Reduce Laboratory Ventilation Operating Costs With Vektor Energy Recovery Lab Exhaust Systems!



Vektor ERS with Vektor-CD
Centrifugal Blowers



Vektor ERS with Vektor-MD
Mixed Flow

Laboratories, by required design, are “energy hogs”. Reduce the operating cost of your lab safely using Vektor energy recovery systems.

Greenheck Vektor energy recovery systems utilize glycol filled run around coils to safely transfer energy between the laboratory exhaust and supply air streams. This sensible only heat transfer system allows the supply and exhaust duct system to be separated and safely prevents the possibility of cross contamination

Greenheck Vektor Energy Recovery System features:

- Energy recovery efficiency to 55%
- Exhaust system flow ranges from 2000 – 250,000+ cfm
- External Static Pressures to 10 in. wg
- Maintains separation integrity between hazardous exhaust and supply air
- Utilizes side inlet centrifugal Vektor-CD or inline mixed flow Vektor-MD blowers
- Insulated double wall plenum, with stainless steel interior
- Corrosion resistant coated extended surface energy recovery coil(s).
- Multiple blower configurations for redundancy and energy saving exhaust flow modulation.
- Constant volume or variable volume lab exhaust systems
- Medium to high efficiency filtration options
- Standard as well as custom system configurations.
- Single source system responsibility
- Engineered and proudly manufactured in the USA



How the Vektor Energy Recovery System Works

- 1** Lab fume hood exhaust and / or general exhaust is drawn into the Vektor Energy Recovery System by the Vektor High Plume Dilution Blower(s).
 - The exhaust flows through disposable particulate filters (optional) and then through an extended surface heat transfer coil that is filled with glycol. The heat between the glycol and the lab exhaust is transferred (glycol warmed in the winter, cooled in the summer).
 - 2** The glycol is then pumped to a pre-conditioning coil in the make-up air conditioning unit. The glycol then transfers it's energy to the make-up air (heating in winter, cooling in summer).
 - 3** The glycol then transfers it's energy to the make-up air (heating in winter, cooling in summer).
- This transfer of energy from the conditioned exhaust to the unconditioned make-up air reduces the laboratory operating cost.

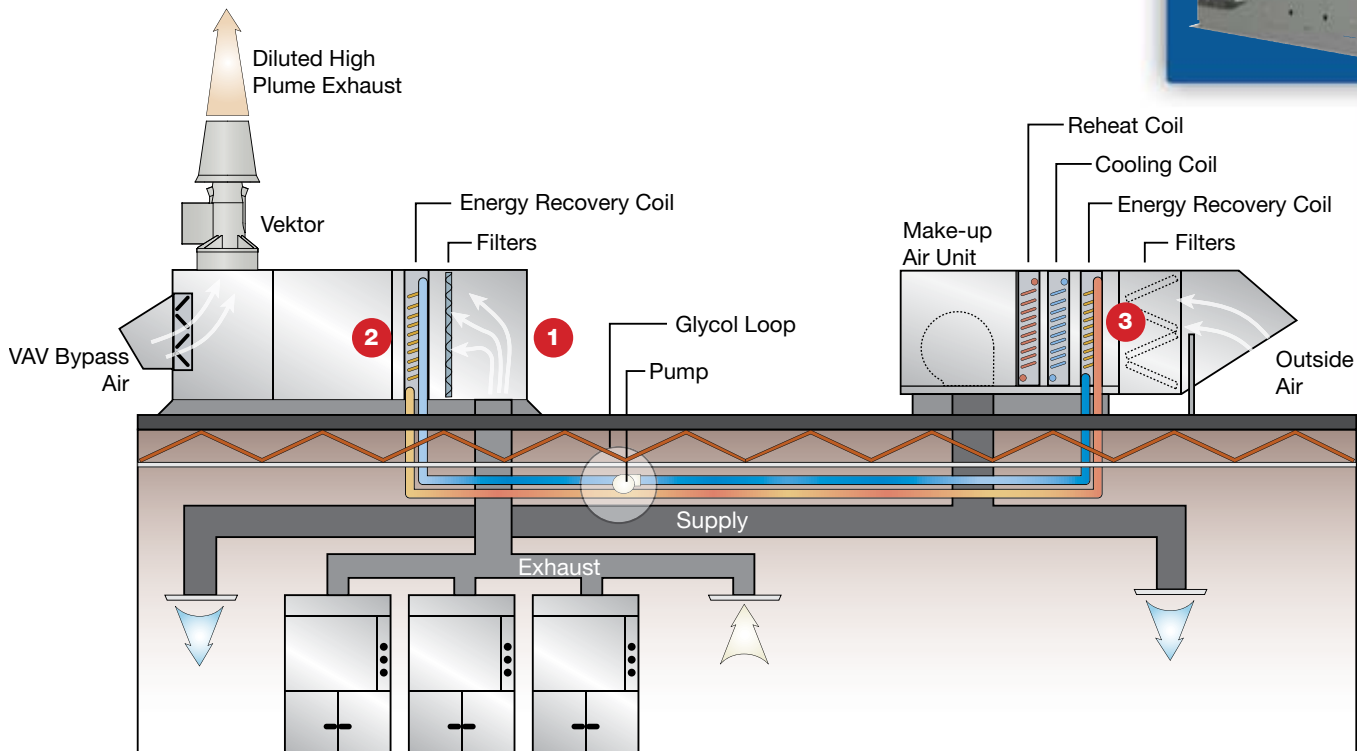
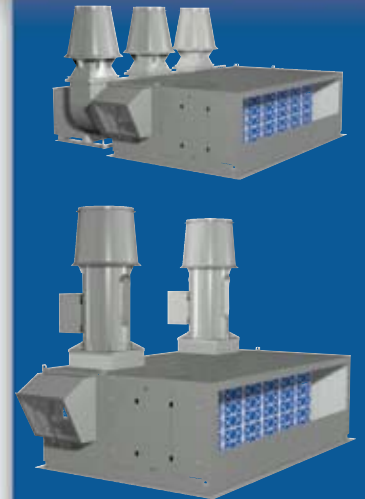

Benefits of the Vektor Energy Recovery System

- Reduced laboratory operating cost
- Physical separation between exhaust and supply air
- Zero cross contamination between supply & Exhaust
- Additional dilution and plume rise of exhaust effluent

Greenheck offers...

- Standard & Custom Designs
- AutoCAD Drawings
- Vektor Blower performance data
- Heat transfer performance data

Family of Lab Exhaust Systems **VEKTOR**TM



Vektor-H



Vektor-MD



Vektor-CD