

Propeller Hooded Roof Fans

Series A - Model AE and AS

Exhaust and Supply Fans

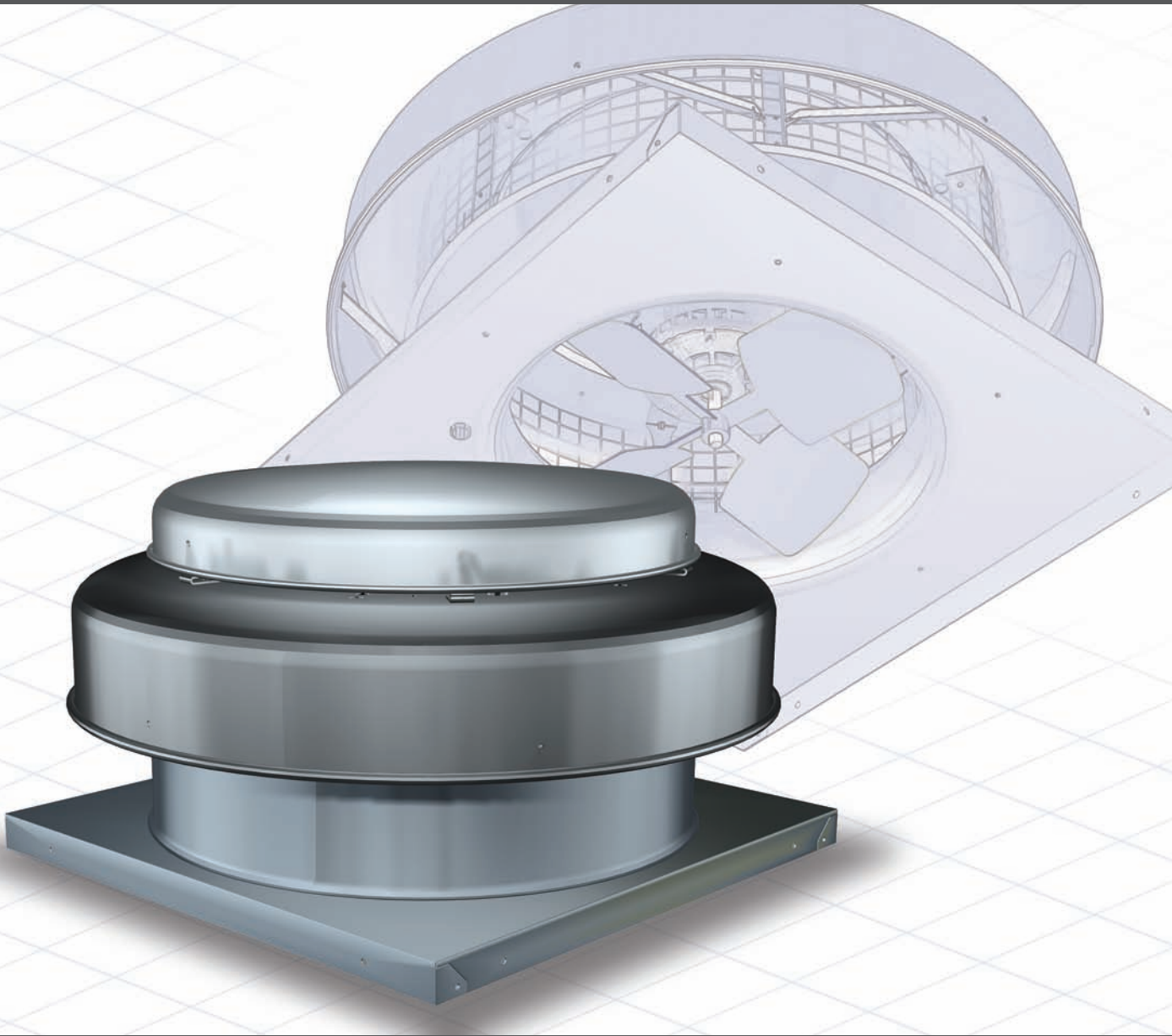

BUILDING VALUE IN AIR.



August
2008

Model AE and AS Propeller Fans



Greenheck's models AE (axial exhaust) and AS (axial supply) spun aluminum direct drive fans are designed for economy and reliability solutions in low pressure/low volume applications. Typical applications include general commercial clean air ventilation.

- Performance capabilities up to 6,000 cfm (10,200 m³/hr) and up to 1.0 in. wg (250 Pa) of static pressure.
- Seven fan sizes are available from 10 to 24 in. (254 to 610 mm) propeller diameter.
- UL Listed for electrical.
- Performance as cataloged is assured. All fan sizes are tested in an AMCA Accredited Laboratory and all models are licensed to bear the AMCA Sound and Air Performance seals.
- Greenheck subjects these products to extensive life testing, assuring you the fans will provide years of reliable performance.

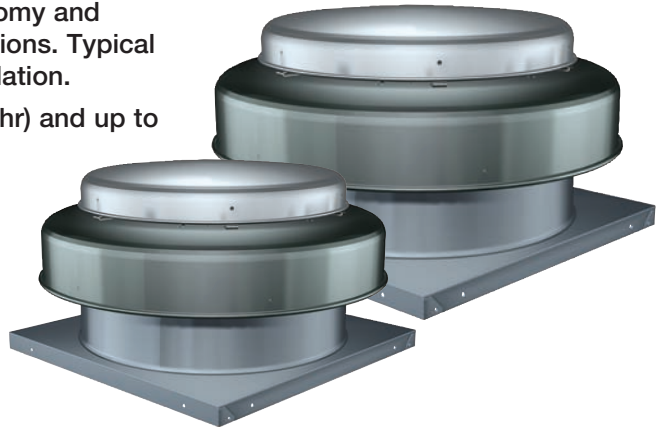

Greenheck Fan Corporation certifies that the models AE and AS fans shown herein are licensed to bear the AMCA seal. The ratings shown are based on tests and procedures performed in accordance with AMCA Publication 211 and AMCA Publication 311 and comply with the requirements of the AMCA Certified Ratings Program. The certified ratings for Models AS and AE are shown on pages 4 thru 7.



Models AE and AS are listed for electrical (UL/cUL 705) File no. E40001

Model Number Code

The model number system is designed to completely identify the fan. The model number is determined by the ventilation type, fan size and performance selected from pages four through seven. A detailed explanation of the model number is shown to the right.

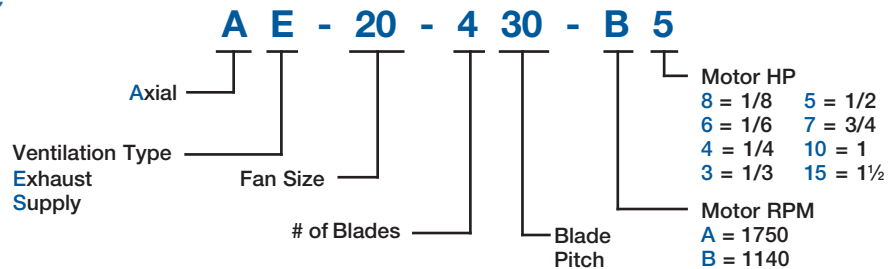

Typical Installation

Model AE and AS fans are designed to meet the needs of general clean air applications. Tests were conducted to assure safe, rugged and reliable operation.

Due to the varying airstreams encountered in commercial ventilation, system designers must be aware of national, state and local codes and guidelines governing these installations. Local code authorities should be consulted before proceeding with any ventilation project.

Internal conduit chase provides means for electrical service connection through fan housing.

When roofing materials extend to the top of the curb, roof curbs should be 1 1/2 inches (3/4 inch on a side) less than the unit curb cap to allow for roofing and flashing.

For recommended damper size and roof opening dimensions, refer to the dimensional data on pages four and six.

Installation must include a means for inspecting, cleaning and servicing the fan.

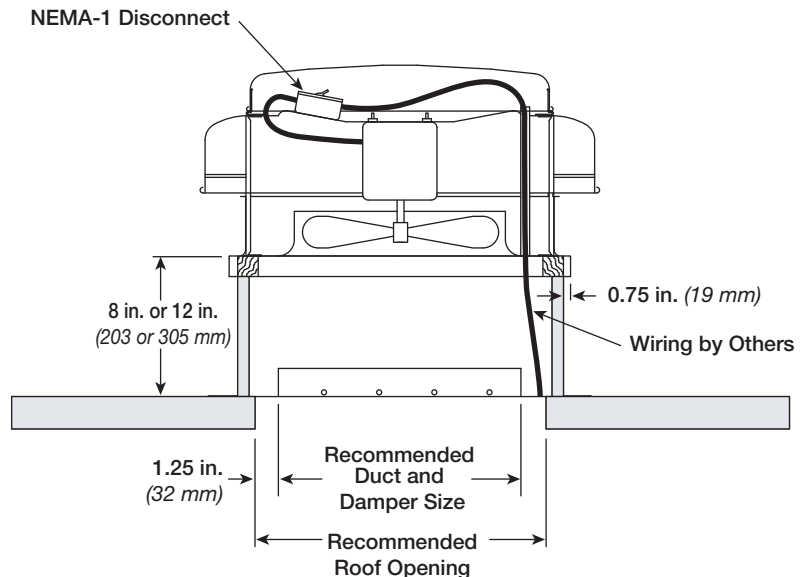

Standard Construction Features

- 1 **PROPELLER** – Fabricated aluminum propeller with steeply pitched blade designed for low rpm, which generates low sound levels. Each propeller is statically and dynamically balanced for long life and quiet operation.
- 2 **SWITCH** – NEMA-1 switch is factory mounted and wiring is provided from the motor as standard (other switches are available). All wiring and electrical components comply with the National Electric Codes (NEC) and are either UL Listed or recognized.
- 3 **MOTOR** – Carefully matched to the fan load and is mounted in the airstream. All motors are compatible with speed controller except “A” speed motors on the size 20.
- 4 **MOTOR COVER** – Constructed of aluminum and attached with stainless steel hardware for easy removal and access to motor.
- 5 **FAN SHROUD** – One-piece, heavy-gauge aluminum with a rolled bead for extra strength.
- 6 **SHROUD BRACES** – Adds structural integrity to the shroud.
- 7 **VIBRATION ISOLATION** – Vibration isolators support the motor and propeller for long life and quiet operation.
- 8 **INTERNAL CONDUIT CHASE** – A large diameter conduit for installing electrical wiring through the curb cap into the motor compartment.
- 9 **CURB CAP** – Curb cap and integral deep spun venturi inlet are constructed of aluminum to prevent corrosion. Curb cap has 5/16 in. (8 mm) prepunched mounting holes to ensure correct attachment to the roof.
- 10 **NAMEPLATE** – Permanent stamped aluminum plate for exact model and serial number identification.
- 11 **GALVANIZED BIRDSCREEN** – 1/2 inch square galvanized rigid wire mesh protects the fan’s discharge from birds or small objects.
- 12 **LOWER WINDBAND** – Heavy-gauge aluminum with formed edges for added strength and weather resistance.

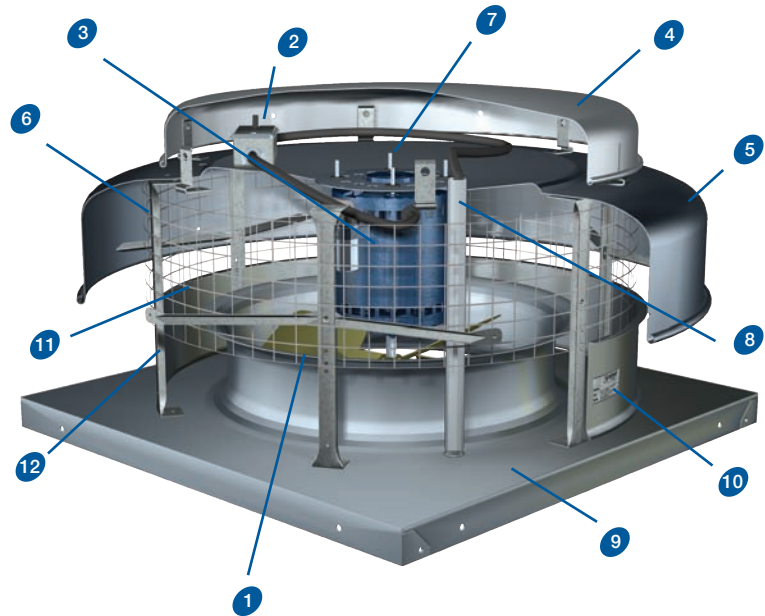

Options and Accessories

ROOF CURBS

Prefabricated roof curbs reduce installation time and costs by ensuring compatibility between the fan, the curb and roof opening.

A wide variety of roof curbs are available, including: flanged, pitched and sound-absorbing.

CURB EXTENSION

Extensions raise the fan discharge above the roof line and provide an accessible mounting location for dampers.

ALUMINUM BIRDSCREEN

1/2 inch square aluminum wire mesh protects the fan’s discharge from birds or small objects.

SPEED CONTROLLERS

Available for providing an economical means of system balancing with direct drive fans.

DAMPERS

Designed to prevent outside air from entering back into the building when fan is off. Includes: gravity and motorized dampers.

COATINGS

Wide variety of coatings and colors are available.

Greenheck coatings and resistance charts can be found in Greenheck’s Product Application Guide for Performance Coatings for Ventilation Products.

DISCONNECT SWITCHES

A wide selection of NEMA rated switches are available for positive electrical shutoff and safety including: dust-tight, rainproof and corrosion-resistant. Switches may be internally or externally mounted.

AE - Axial Exhaust Dimensions

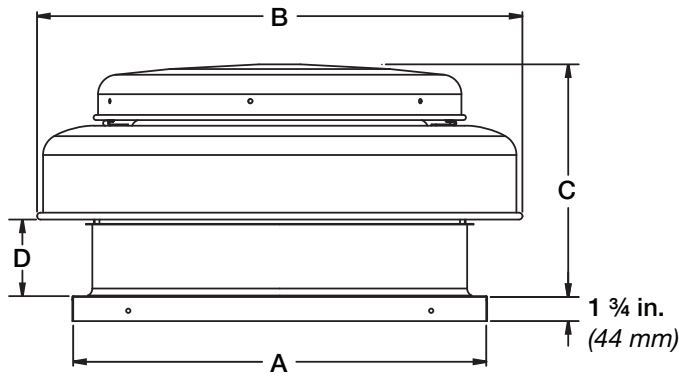

Dimensional Data	Model AE Size						
	10	12	14	16	18	20	24
A - Curb Cap	19 (483)	22 (559)	22 (559)	26 (660)	30 (762)	34 (863)	34 (863)
B	24 ⁵ / ₈ (625)	28 ⁵ / ₈ (727)	28 ⁵ / ₈ (727)	35 ¹ / ₄ (895)	35 ¹ / ₄ (895)	42 (1067)	42 (1067)
C	15 ¹ / ₂ (394)	16 ¹ / ₂ (419)	16 ¹ / ₂ (419)	17 ¹ / ₄ (438)	17 ¹ / ₄ (438)	17 ¹ / ₂ (445)	17 ¹ / ₂ (445)
D	5 ¹ / ₂ (140)	6 ¹ / ₄ (159)	6 ¹ / ₄ (159)	6 ¹ / ₄ (159)	6 ¹ / ₄ (159)	6 ¹ / ₄ (159)	6 ¹ / ₄ (159)
Damper Size	12 (305)	12 (305)	14 (356)	16 (406)	18 (457)	24 (610)	24 (610)
Roof Opening	14 ¹ / ₂ (368)	14 ¹ / ₂ (368)	16 ¹ / ₂ (419)	18 ¹ / ₂ (470)	20 ¹ / ₂ (521)	26 ¹ / ₂ (673)	26 ¹ / ₂ (673)
Shroud Thickness	0.050 (1.3)	0.050 (1.3)	0.050 (1.3)	0.063 (1.6)	0.063 (1.6)	0.063 (1.6)	0.063 (1.6)
Motor Cover Thickness	0.050 (1.3)	0.050 (1.3)	0.050 (1.3)	0.050 (1.3)	0.050 (1.3)	0.050 (1.3)	0.050 (1.3)
Unit Weight	34 (15)	44 (20)	51 (23)	63 (29)	70 (32)	97 (44)	89 (40)

All dimensions in inches (millimeters) and weight in pounds (kilograms).

AE - Axial Exhaust Performance Charts

1140 RPM

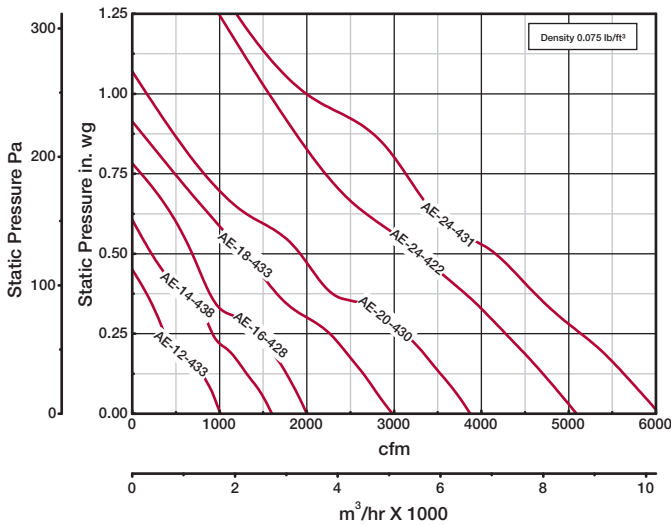

1725 RPM

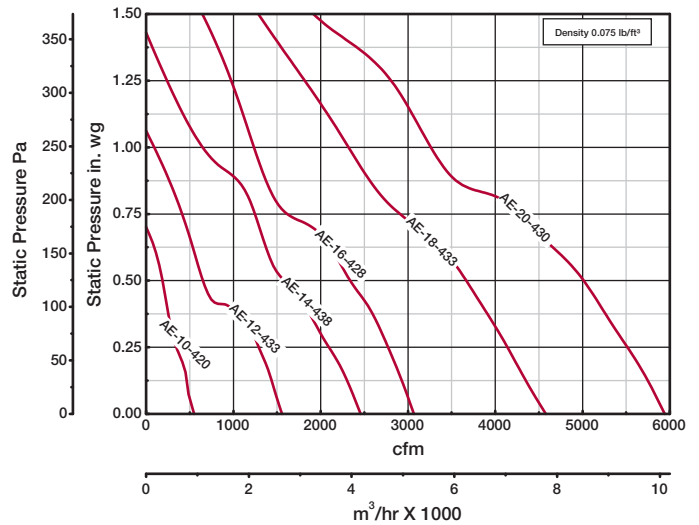

Performance certified is for Model AE exhaust for installation type A: Free inlet, Free outlet. Performance ratings include the effects of a birdscreen.

AE - Axial Exhaust Performance



Model Number	HP (Size)	Fan RPM		CFM / Static Pressure in Inches WG									
				0	0.10	0.125	0.20	0.25	0.375	0.50	0.625	0.75	1.0
AE-10-420-A8	1/8	1750	CFM	550	475	465	409	347	255	189			
			BHP	0.025	0.03	0.031	0.035	0.038	0.044	0.05			
			Sones	9.6	10.4	10.5	11.9	13.2	12.0	16.8			
AE-12-433-B6	1/6	1140	CFM	1014	853	803	458	376	144				
			BHP	0.03	0.036	0.037	0.039	0.044	0.052				
			Sones	5.1	5.1	5.1	7.0	7.4	8.6				
AE-12- 433-A4	1/4	1750	CFM	1556	1460	1437	1355	1291	1055	672	538	386	
			BHP	0.107	0.112	0.115	0.125	0.131	0.135	0.146	0.165	0.176	
			Sones	9.0	8.9	8.8	8.9	8.9	10.5	14.5	15.0	15.7	
AE-14- 438-B6	1/6	1140	CFM	1601	1381	1311	1092	925	626	273			
			BHP	0.093	0.1	0.102	0.098	0.1	0.111	0.119			
			Sones	8.2	7.6	7.5	8.0	8.4	9.6	10.7			
AE-14-438-A5	1/2	1750	CFM	2457	2332	2298	2186	2093	1875	1603	1381	1244	716
			BHP	0.337	0.342	0.345	0.357	0.365	0.369	0.355	0.369	0.393	0.41
			Sones	16.8	16.4	16.3	16.2	16.2	16.1	19.2	19.5	18.4	22
AE-16- 428-B6	1/6	1140	CFM	1999	1817	1764	1563	1418	904	682			
			BHP	0.092	0.103	0.108	0.119	0.124	0.127	0.14			
			Sones	10.5	9.2	9.0	8.6	8.4	12.2	11.6			
AE-16- 428-A5	1/2	1750	CFM	3068	2958	2928	2834	2771	2590	2339	2112	1686	1257
			BHP	0.334	0.348	0.352	0.367	0.377	0.413	0.435	0.452	0.448	0.478
			Sones	17.9	17.2	17.1	16.4	16.1	15.7	15.5	15.2	25	21
AE-18- 433-B3	1/3	1140	CFM	2982	2713	2645	2423	2264	1669	1276	881	499	
			BHP	0.249	0.266	0.27	0.28	0.286	0.285	0.298	0.319	0.346	
			Sones	11.7	11.2	11.1	11.2	11.4	14.8	14.4	15.0	17.1	
AE-18- 433-A10	1	1750	CFM	4578	4395	4349	4224	4141	3908	3660	3357	2935	2327
			BHP	0.902	0.924	0.93	0.953	0.968	0.995	1.02	1.041	1.039	1.045
			Sones	28	28	28	29	29	29	28	28	29	31
AE-20- 430-B5	1/2	1140	CFM	3871	3606	3531	3300	3100	2301	1925	1313		
			BHP	0.258	0.282	0.289	0.305	0.318	0.331	0.361	0.378		
			Sones	11.3	10.9	10.9	11.2	11.7	13.7	16.8	15.7		
AE-20- 430-A15	1½	1750	CFM	5943	5785	5745	5605	5507	5260	5007	4650	4246	3295
			BHP	0.932	0.967	0.975	1.006	1.027	1.075	1.113	1.169	1.211	1.238
			Sones	23	22	22	22	23	23	25	24	25	35
AE-24- 422-B5	1/2	1140	CFM	5091	4782	4703	4452	4277	3813	3279	2700	2252	
			BHP	0.521	0.541	0.546	0.563	0.577	0.6	0.625	0.625	0.641	
			Sones	17.2	14.2	13.9	13.7	13.6	13.4	17.0	21	21	
AE-24- 431-B10	1	1140	CFM	6042	5714	5626	5361	5137	4619	4146	3476	3136	2028
			BHP	1.003	1.024	1.028	1.039	1.053	1.087	1.098	1.073	1.119	1.167
			Sones	19.8	20	21	20	20	20	21	24	24	24

Performance certified is for Model AE exhaust for installation type A: Free inlet, Free outlet. Performance ratings include the effects of a birdscreen. The sound ratings shown are loudness values in fan sones at a distance of 1.5 m (5 ft) in a hemispherical free field calculated per AMCA International Standard 301. Values shown are for Installation Type A: free inlet hemispherical sone levels.

AS - Axial Supply Dimensions

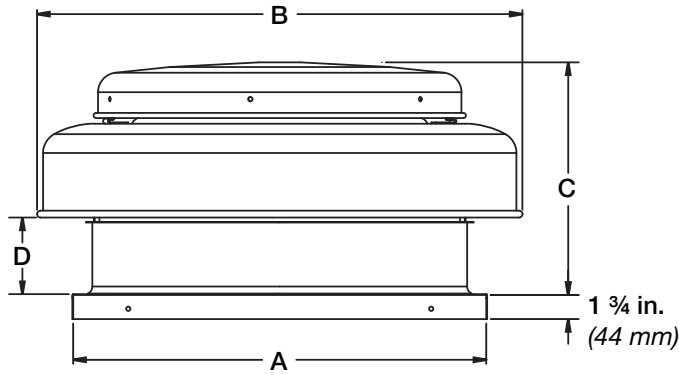

Dimensional Data	Model AS Size						
	10	12	14	16	18	20	24
A - Curb Cap	19 (483)	22 (559)	22 (559)	26 (660)	30 (762)	34 (863)	34 (863)
B	24 ⁵ / ₈ (625)	28 ⁵ / ₈ (727)	28 ⁵ / ₈ (727)	35 ¹ / ₄ (895)	35 ¹ / ₄ (895)	42 (1067)	42 (1067)
C	15 ¹ / ₂ (394)	16 ¹ / ₂ (419)	16 ¹ / ₂ (419)	17 ¹ / ₄ (438)	17 ¹ / ₄ (438)	17 ¹ / ₂ (445)	17 ¹ / ₂ (445)
D	5 ¹ / ₂ (140)	6 ¹ / ₄ (159)	6 ¹ / ₄ (159)	6 ¹ / ₄ (159)	6 ¹ / ₄ (159)	6 ¹ / ₄ (159)	6 ¹ / ₄ (159)
Damper Size	12 (305)	12 (305)	14 (356)	16 (406)	18 (457)	24 (610)	24 (610)
Roof Opening	14 ¹ / ₂ (368)	14 ¹ / ₂ (368)	16 ¹ / ₂ (419)	18 ¹ / ₂ (470)	20 ¹ / ₂ (521)	26 ¹ / ₂ (673)	26 ¹ / ₂ (673)
Shroud Thickness	0.050 (1.3)	0.050 (1.3)	0.050 (1.3)	0.063 (1.6)	0.063 (1.6)	0.063 (1.6)	0.063 (1.6)
Motor Cover Thickness	0.050 (1.3)	0.050 (1.3)	0.050 (1.3)	0.050 (1.3)	0.050 (1.3)	0.050 (1.3)	0.050 (1.3)
Unit Weight	34 (15)	44 (20)	51 (23)	63 (29)	70 (32)	97 (44)	89 (40)

All dimensions in inches (millimeters) and weight in pounds (kilograms).

AS - Axial Supply Performance Charts

1140 RPM

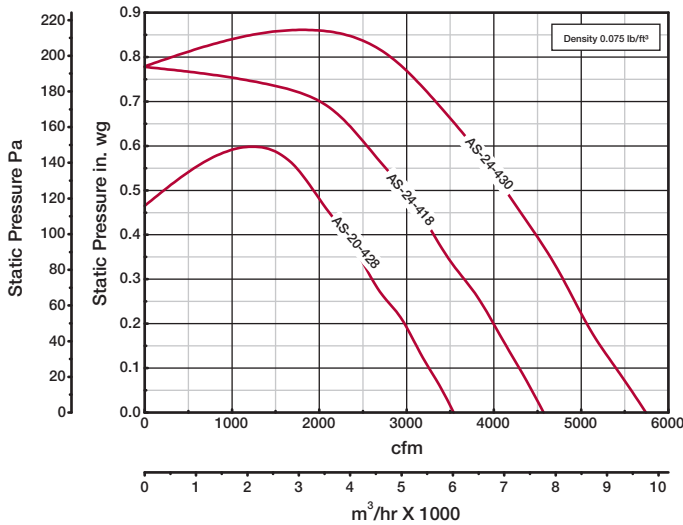

1725 RPM

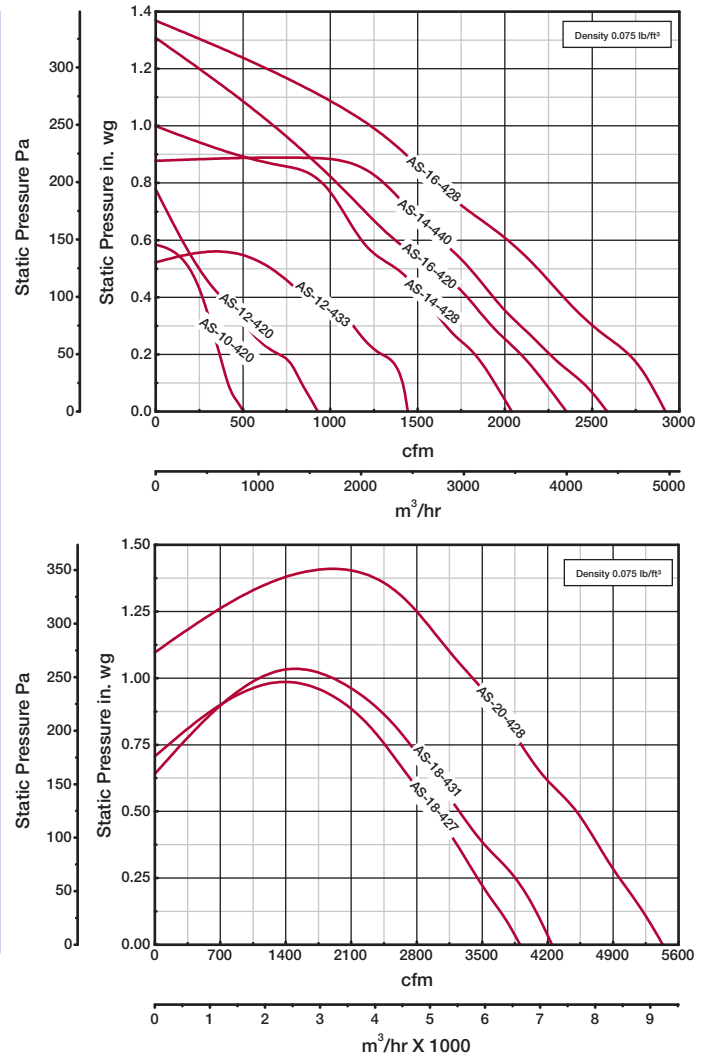

Performance certified is for Model AS supply for installation type A: Free inlet, Free outlet. Performance ratings include the effects of a birdscreen.

AS - Axial Supply Performance



Model Number	HP (Size)	Fan RPM		CFM / Static Pressure in Inches WG									
				0	0.10	0.125	0.20	0.25	0.375	0.50	0.625	0.75	1.0
AS-10-420-A8	1/8	1750	CFM	503	413	401	366	343	280	188			
			BHP	0.022	0.029	0.03	0.033	0.035	0.043	0.052			
			Sones	7.9	9.1	9.2	9.8	10.2	10.2	10.7			
AS-12-420-A4	1/4	1750	CFM	929	835	813	708	595	415				
			BHP	0.037	0.046	0.047	0.054	0.058	0.068				
			Sones	9.6	8.9	8.9	11.4	14.3	12.6				
AS-12-433-A4	1/4	1750	CFM	1444	1412	1400	1294	1203	953	641			
			BHP	0.093	0.1	0.105	0.107	0.123	0.135	0.148			
			Sones	11.4	11.5	11.6	11.8	12.2	15.1	15.8			
AS-14-428-A4	1/4	1750	CFM	2041	1940	1912	1827	1742	1567	1380	1155	1018	
			BHP	0.127	0.142	0.145	0.155	0.172	0.195	0.209	0.228	0.245	
			Sones	16.1	15.8	15.7	15.8	15.9	15.9	18.4	18.9	17.3	
AS-14-440-A5	1/2	1750	CFM	2586	2442	2395	2261	2176	1971	1799	1588	1380	
			BHP	0.32	0.329	0.331	0.338	0.346	0.375	0.415	0.436	0.459	
			Sones	20	19.9	19.8	19.9	19.9	19.8	21	21	19.9	
AS-16-420-A5	1/2	1750	CFM	2353	2229	2195	2093	2008	1819	1597	1330	1121	
			BHP	0.177	0.192	0.195	0.206	0.221	0.236	0.25	0.268	0.286	
			Sones	20	19.7	19.5	19.6	19.6	19.5	21	22	21	
AS-16-428-A7	3/4	1750	CFM	2920	2826	2802	2693	2602	2376	2188	1965	1693	1200
			BHP	0.311	0.331	0.336	0.349	0.356	0.379	0.428	0.436	0.466	0.517
			Sones	21	21	21	20	20	19.9	19.7	21	25	23
AS-18-427-A7	3/4	1750	CFM	3906	3739	3690	3543	3454	3228	2990	2725	2454	
			BHP	0.545	0.592	0.603	0.636	0.647	0.676	0.703	0.731	0.756	
			Sones	30	29	28	28	27	28	28	28	28	
AS-18-431-A10	1	1750	CFM	4247	4110	4076	3938	3846	3526	3259	2998	2724	
			BHP	0.725	0.763	0.773	0.789	0.8	0.888	0.916	0.943	0.972	
			Sones	31	30	30	30	30	29	29	28	28	
AS-20-428-B5	1/2	1140	CFM	3488	3202	3125	2911	2715	2315	1847			
			BHP	0.212	0.228	0.232	0.256	0.274	0.305	0.332			
			Sones	16.7	17.5	17.7	18.1	18.4	17.1	18.9			
AS-20-428-A15	1½	1750	CFM	5355	5181	5137	4987	4886	4648	4408	4073	3830	3272
			BHP	0.767	0.79	0.795	0.814	0.827	0.879	0.94	1.012	1.056	1.142
			Sones	29	31	32	33	34	34	34	33	33	33
AS-24-418-B5	1/2	1140	CFM	4569	4289	4215	3992	3841	3392	2958	2422		
			BHP	0.369	0.392	0.399	0.415	0.422	0.453	0.474	0.497		
			Sones	24	23	23	23	23	22	22	19.4		
AS-24-430-B10	1	1140	CFM	5742	5401	5315	5066	4929	4556	4131	3650	3066	
			BHP	0.855	0.884	0.892	0.915	0.932	0.973	1.012	1.05	1.091	
			Sones	29	25	25	24	24	25	26	27	29	

Performance certified is for Model AS supply for installation type A: Free inlet, Free outlet. Performance ratings include the effects of a birdscreen. The sound ratings shown are loudness values in fan sones at a distance of 1.5 m (5 ft) in a hemispherical free field calculated per AMCA International Standard 301. Values shown are for Installation Type A: free outlet hemispherical sone levels.

Typical Specifications

Direct drive axial roof exhaust fans shall be provided as follows:

The fan propeller shall be constructed of aluminum with a swept, steeply pitched blade. A standard setscrew shall lock the propeller to the motor shaft. Propellers shall be statically and dynamically balanced. The fan housing shall be constructed of heavy-gauge aluminum with a rigid internal support structure and a birdscreen.

Motors shall be permanently lubricated, heavy-duty type, carefully matched to the fan load and furnished at the specified RPM, voltage, phase, and enclosure. Motors shall be readily accessible for maintenance.

A disconnect switch shall be factory installed and wired from the fan motor to a junction box within the motor compartment. A conduit chase shall be provided through the curb cap to the motor compartment for ease of electrical wiring.

All fans shall bear the AMCA Certified Ratings Seals for Sound and Air Performance.

Each fan shall bear a permanently affixed manufacturer's engraved metal nameplate containing the model number and individual serial number for future identification.

Fans shall be model AS and AE as manufactured by Greenheck Fan Corporation, Schofield, Wisconsin.

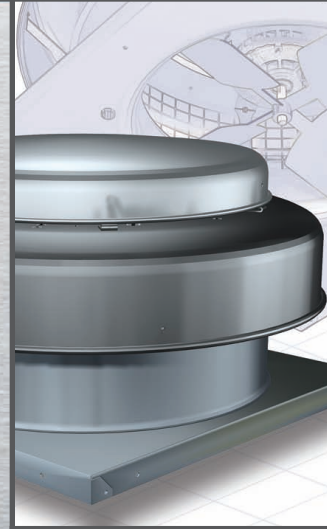

Building Value in Air

Greenheck delivers value to mechanical engineers by helping them solve virtually any air quality challenges their clients face with a comprehensive selection of

top quality, innovative air-related equipment. We offer extra value to contractors by providing easy-to-install, competitively priced, reliable products that arrive on time.

And building owners and occupants value the energy efficiency, low maintenance and quiet dependable operation they experience long after the construction project ends.

Our Warranty

Greenheck warrants this equipment to be free from defects in material and workmanship for a period of one year from the purchase date. Any units or parts which prove defective during the warranty period will be replaced at our option when returned to our factory, transportation prepaid. Motors are warranted by the motor manufacturer for a period of one year. Should motors furnished by Greenheck prove defective during this period, they should be returned to the nearest authorized motor service station. Greenheck will not be responsible for any removal or installation costs.

As a result of our commitment to continuous improvement, Greenheck reserves the right to change specifications without notice.



Prepared to Support Green Building Efforts

