

Recirculating Roof Fans

Models ESRMD, ESRMDF and ERD

Four-Way Fan



- Exhaust
- Supply
- Mix
- Recirculate

 **GREENHECK**
Building Value in Air.



BUILDING VALUE IN AIR.

October
2005

Recirculating Roof Fans

Exhaust/Supply/Recirculation/Mix



Model ESRMD

Ventilation requirements are often subject to daily or seasonal changes in temperature. The Greenheck Four-Way Fan offers the flexibility to meet changing needs and to maintain comfortable temperatures in factories, warehouses and other facilities with high ceilings. When temperatures change with production processes or seasonal shifts, the Four-Way fan can exhaust, supply, recirculate or mix air as required.

- Model ESRMD fans are available in six direct drive sizes.
- Performance capacities range from 4,000 cfm to 40,000 cfm and up to 0.375 in. wg of static pressure.
- Exhaust, supply and recirculate modes perform equally.

Cost Savings

By exhausting excess heat, supplying cool air, recirculating stratified warm air, and mixing supply air with recirculated air, the Four-Way fan also saves heating and cooling costs. When one fan offers four functions, further cost reductions result. Fewer fans required on the job means lower initial costs and lower installation costs, with fewer roof penetrations.

One Fan - Four Functions

1. Exhaust

Evacuates excess heat to reduce cooling costs.

The exhaust/supply damper is open and the recirculation dampers are closed.

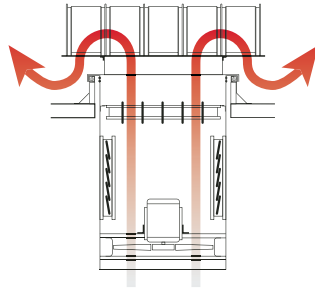

2. Supply

Fresh air can be supplied when outside temperatures are cooler (as at night) to reduce cooling costs.

The exhaust/supply damper is open and the recirculation dampers are closed.

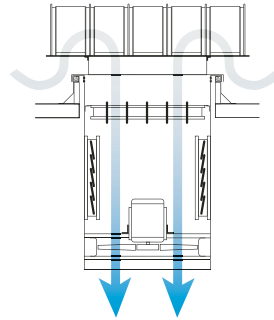

3. Recirculation

Destratifies warm air accumulated at ceiling level and directs it downward to reduce heating costs.

The exhaust/supply damper is closed and the recirculation dampers are open.

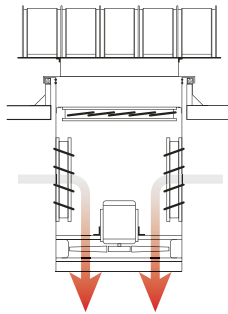

4. Mix

Comfortable temperatures can be maintained by tempering supply air with warmer air trapped at ceiling level.

The exhaust/supply damper and the recirculation dampers are linked to work in combination.

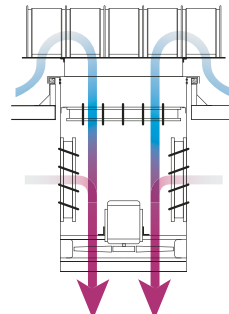

Model ERD

The model ERD upblast fan is available for applications that require exhaust and recirculation, and do not require supply or mixed air. The model ERD has an upblast windband and butterfly dampers in lieu of the Four-Way fan hood. The windband is constructed of galvanized steel with butterfly dampers constructed of aluminum. Aluminum construction is optional for the windband.

The model ERD offers the same performance as the Four-Way fan, except in the lower ranges where the minimum CFM must be maintained to open the butterfly dampers.

Minimum CFM required to open butterfly dampers	
Size	CFM
24	3947
30	6034
36	7618
42	11045
48	12817
54	21425

Standard Construction Features

Fan hoods and bases are constructed of galvanized steel. Optional aluminum construction is available. Hood panels are arched and precision roll formed for strength and weather tightness. They are bolted to heavy gauge support angles. All hood sizes ship fully assembled except for 54 in. non-filtered, 48 in. and 54 in. filtered.

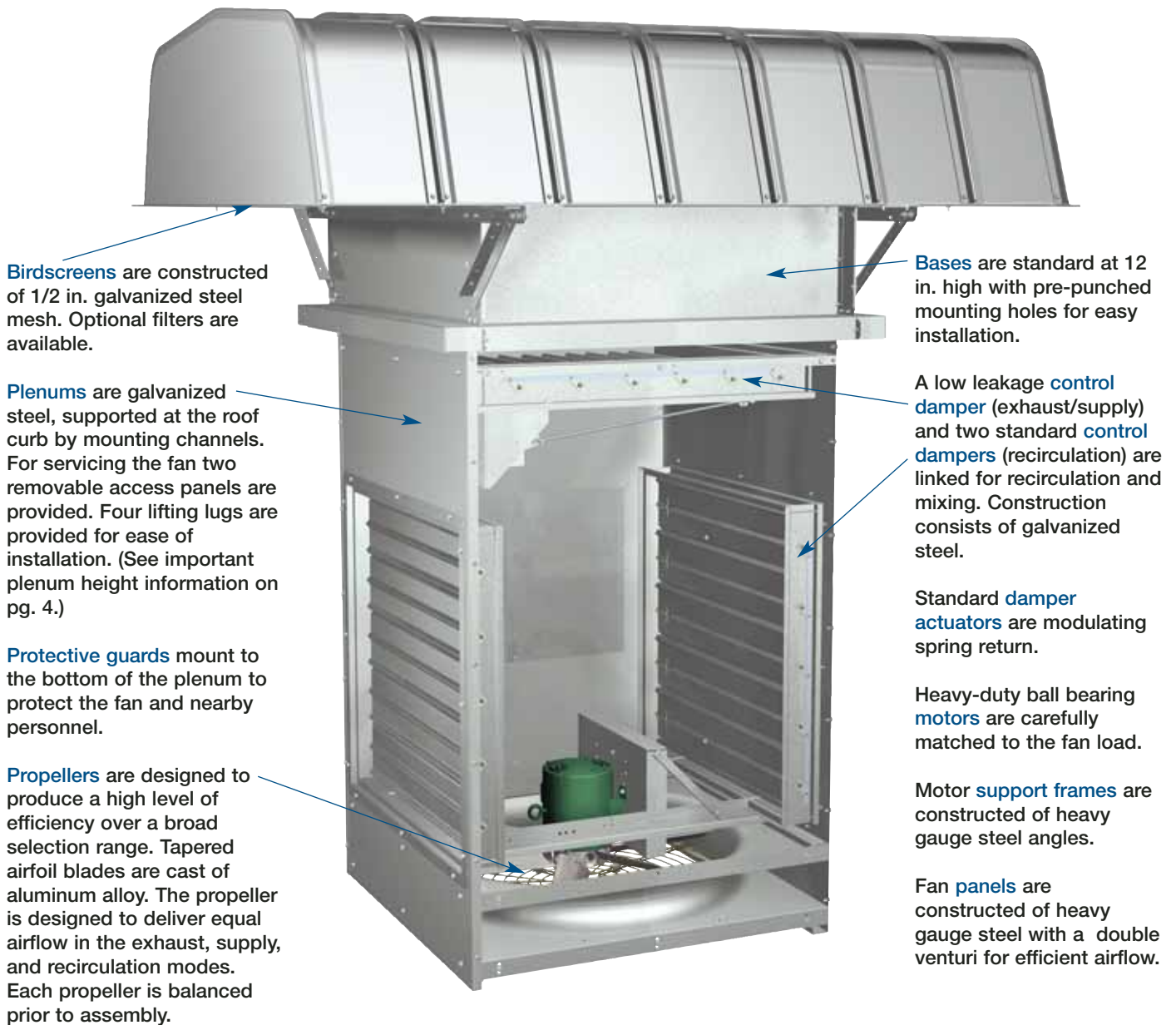

Installation Sequence

1. The roof curb is mounted and secured over the roof opening.
2. The plenum (factory assembled) is lowered through the curb and roof opening until its mounting channels rest on the roof curb. Lifting lugs are provided. (Fig. 1)
3. The fan hood is lowered onto the curb/plenum assembly. (Fig. 1)
4. The hood and plenum are secured to the roof curb. (Fig. 2)

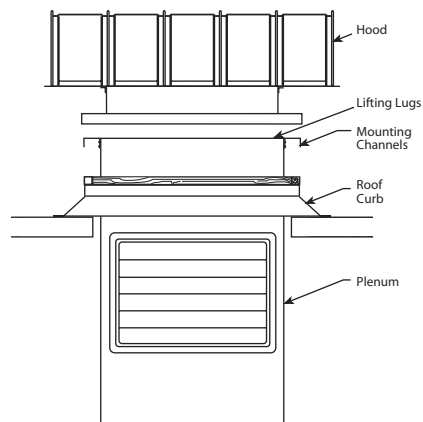

Fig. 1

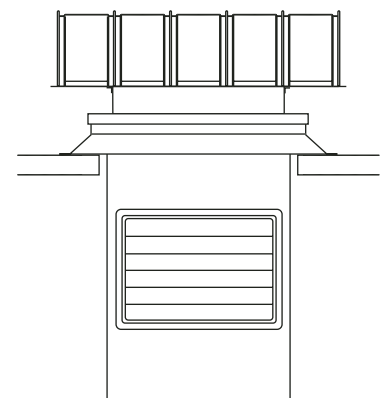

Fig. 2

Options & Accessories

Filters

For applications where contaminants must be removed from air supplied to the building, washable 2 in. aluminum mesh filters are available. Filters are mounted in open end racks for easy removal. In fan sizes 36 in. and larger, access panels are provided to allow filter removal without raising the hood.

Roof Curbs

Prefabricated roof curbs are available to reduce installation time and costs by ensuring compatibility between the fan and the roof opening. See Greenheck's roof curb catalog for complete details. A wide variety of roof curbs are available, including: flanged, pitched and sound-absorbing.

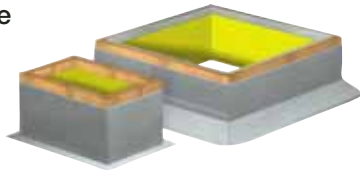

Coatings

Special coatings are available for decorative or protective purposes. Decorative coatings can be applied to exterior surfaces of the hood, base and plenum. Protection from corrosive atmospheres requires individual consideration.

Disconnect Switches

NEMA 1 and NEMA 3R disconnect switches are available for positive electrical shutoff and protection of personnel. Disconnects are shipped loose for field mounting.



Exhaust/Supply Damper Option

Insulated low leakage dampers are available for applications where an indoor/outdoor temperature differential must be maintained.

Hood Insulation

Hoods can be lined with 1/2 in. fiberglass insulation to prevent condensation and reduce sound levels.

Motor Options

Motor enclosure options include open drip proof and totally enclosed for single speed motors, and open drip proof for two speed motors. Single phase motors are available in 115/208/230 volt. Three phase motors are available in 208/230/460 and 575 volt.

Tie-Down Points

Four galvanized steel brackets are available as cable attachment points at the ends of each hood support rail. Cable tie-downs prevent damage to the hood in locations where unusually strong winds occur. (Cables are by others.)

Diffusers

Discharge diffusers, mounted to the bottom of the plenum, offer the ability to direct the airflow of the fan. Four manually adjustable quadrants can be set to direct air in any direction desired. Construction is galvanized steel. Guards are necessary with or without diffusers.

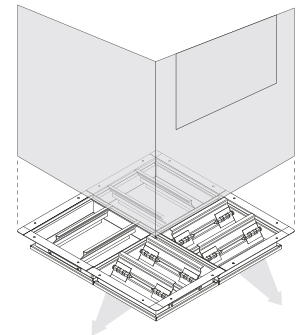

Plenum Height Option

Plenum height can be increased in 12 in. increments to clear pitched roofs, beams and other solid obstructions that may interfere with airflow into the recirculation dampers. The standard dimension from the top of the plenum to the top of the recirculation dampers is 20 in.

Installation Examples

Fig.1(left)- shows a truss type that would not typically interfere with airflow and does not require increasing plenum height. Fig.1 (right)- shows a solid beam obstruction requiring plenum extension to clear.

The Fig. 2 installation requires extension of the plenum to clear the pitch of the roof.

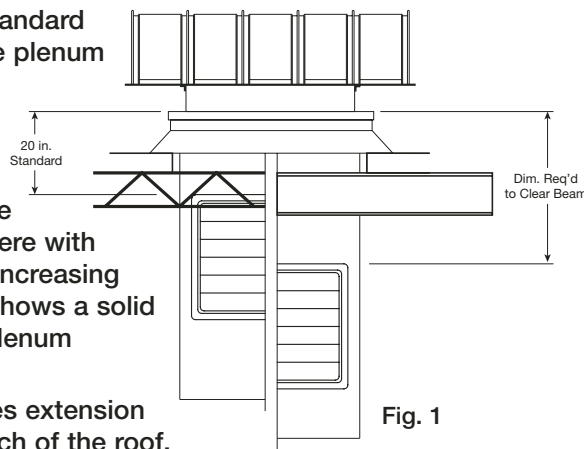

Fig. 1

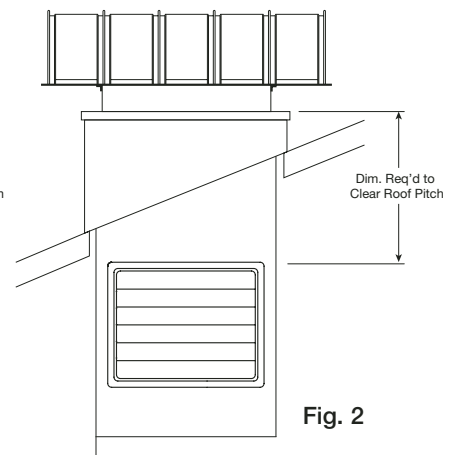

Fig. 2

The Control Center

Designed specifically for the Greenheck Four-Way fan, the control center allows the operator to manually change the modes of operation of the fan from a convenient remote location.

This control center is more cost effective than controls fabricated in the field. It offers savings in both time and expense, since ease of installation, compatibility, and qualities are assured. These units are complete, self-contained control packages, with motor starters included. (Wiring from the fan to the control center is by others.)

Controls are housed in a NEMA 1 cabinet constructed of heavy gauge steel and coated with Greenheck's Permator™ finish. A door interlocking disconnect switch ① is provided to help prevent electrical shock when the door is opened.

Operating Mode Combinations

Control centers are available in any one of the following combinations, which must be specified when ordering:

- **ESRM-CC** — Exhaust/Supply/Recirculate/Mix
- **SRM-CC** — Supply/Recirculate/Mix only
- **ESR-CC** — Exhaust/Supply/Recirculate only
- **ER-CC** — Exhaust/Recirculate only

Controls

Mode Selector

The mode selector switch ② is used to engage the desired fan function. The four functions are described below:

Exhaust Mode

Energizes the “reverse” contactor in the control center to allow the fan to exhaust air from the building. The control also energizes the damper actuator, driving the top damper open, and the side dampers closed. If the fan was previously running in the Supply, Recirculate, or Mix mode, or the power was removed from the control center, there will be a delay* before the fan starts again.

Supply Mode

Energizes the “forward” contactor in the control center to allow the fan to supply air to the building and energizes the damper actuator, driving the top damper open, and the side dampers closed. If the fan was previously running in the Exhaust mode, or the power was removed from the control center, there will be a time delay* before the fan starts.

Recirculate Mode

Energizes the “forward” contactor in the control center to allow the fan to recirculate air in the building. The damper actuator is not energized, so the top damper remains closed and the side dampers are open. If the fan was previously running in the Exhaust mode, or the power was removed from the control center, there will be a time delay* before the fan starts.

Mix Mode

Energizes the “forward” contactor in the control center to allow the fan to either supply or recirculate the air in the building. The damper actuator is energized and is modulated by the Honeywell T775 temperature controller located in the control cabinet. The temperature controller is programmable to either work in a cool or heat mode, and to have temperature setpoints. The operator would program the controller, depending on the building needs, and the dampers would vary position between supply and recirculate to try and maintain the temperature programmed. If the fan was previously running in the Exhaust mode, or the power was removed from the control center, there will be a time delay* before the fan starts.

*Delay of 5 minutes for a 24 in. fan or 10 minutes for a 30 in. and larger.

Fans sized at 42 in. and smaller, one damper actuator motor is used in the fan to position the dampers, with linkage tying them together. For 48 in. and 54 in. fans, two actuator motors are used to position the dampers, with linkage tying them together.

Temperature Control

Fans specified with the mix mode (ESRM or SRM only) include a temperature controller ③. A remote temperature sensor is field mounted below the fan discharge in the airstream. The modulating damper actuator(s) is driven by the solid state temperature controller to open or close the exhaust/supply and recirculation dampers as required to maintain the preset temperature. In the other modes, it will display the temperature at the plenum of the fan, but has no effect on its operation.

Options

- An indicator light mounted on the control panel door is available to indicate power to the fan.
- An access opening is provided in the door of units with temperature controls to allow the control to be adjusted with the door closed.



Control Center Model (1 Speed, 3 Phase)	Number of Fans Per Control Center			
	1	2	3	4
ESRM-CC 24-42	X	X	X	
ESRM-CC 48-54	X			
SRM-CC 24-42	X	X	X	
SRM-CC 48-54	X			
ESR-CC 24-54	X	X	X	X
ER-CC 24-54	X	X	X	X
ES-CC 24-60	X	X	X	X
SR-CC 24-54	X	X	X	X

Performance Data

This catalog shows fan performance ratings with BHP's as much as 20% over the motor's nameplate horsepower. Motor life is dependent on the operating temperature of the motor. Motors provided are sufficiently cooled to allow operation up to 20% above their horsepower ratings. This does not reduce motor life or performance and therefore is economically desirable.

MODEL NUMBER	RPM	HP	MAX BHP	SONES @ 0.125	CFM / STATIC PRESSURE IN INCHES W.G.			
					0.000	0.125	0.250	0.375
ESRMD-24-420-B3	1160	1/3	0.37	20	4733	4023	2810	
ESRMD-24-430-B5	1160	1/2	0.60	22	5525	4589	3109	
ESRMD-24-415-A7	1750	3/4	0.89	33	6096	5700	5244	4685
ESRMD-24-420-A10	1750	1	1.26	42	7140	6711	6213	5659
ESRMD-24-622-A15	1750	1½	1.77	43	8005	7747	7327	6921
ESRMD-30-427-C5	870	1/2	0.55	18.0	7595	5735	3303	
ESRMD-30-418-B7	1160	3/4	0.85	29	8995	7945	6448	4393
ESRMD-30-425-B10	1160	1	1.15	30	9965	8698	7195	5192
ESRMD-30-625-B15	1160	1½	1.59	35	11325	10326	9026	6757
ESRMD-30-415-A20	1750	2	2.30	59	12005	11398	10695	9985
ESRMD-30-420-A30	1750	3	3.23	61	14054	13328	12576	11768
ESRMD-30-625-A50	1750	5	5.46	73	17085	16463	15782	15046
ESRMD-36-410-C5	870	1/2	0.55	23	7899	5850	3156	
ESRMD-36-614-C7	870	3/4	0.88	25	10062	8676	6800	
ESRMD-36-620-C10	870	1	1.37	26	11554	10164	7440	
ESRMD-36-626-C15	870	1½	1.73	28	13424	11956	9487	
ESRMD-36-615-B20	1160	2	2.39	45	13966	12858	11454	9974
ESRMD-36-623-B30	1160	3	3.66	46	17261	15948	14605	13369
ESRMD-42-413-C10	870	1	1.14	26	13175	11069	7950	4200
ESRMD-42-615-C15	870	1½	1.73	27	16063	14358	12205	9001
ESRMD-42-620-C20	870	2	2.29	33	18275	16513	14260	11465
ESRMD-42-629-C30	870	3	3.38	35	21264	19373	17171	13941
ESRMD-42-621-B50	1160	5	5.63	55	24776	23430	22078	20377
ESRMD-48-618-F15	680	1½	1.71	26	19446	16442	11939	
ESRMD-48-616-F20	680	2	2.20	28	20886	18974	16481	
ESRMD-48-623-F30	680	3	3.56	32	24368	22235	17320	14516
ESRMD-48-612-C20	870	2	2.31	38	20218	17864	15156	11386
ESRMD-48-617-C30	870	3	3.29	41	23020	20817	17930	14322
ESRMD-48-619-C50	870	5	5.66	45	28511	26885	25194	23287
ESRMD-48-618-B75	1160	7½	8.52	66	32435	29892	29139	27139
ESRMD-48-620-B100	1160	10	11.85	74	36151	35143	34085	32966
ESRMD-54-615-F20	680	2	2.34	35	23198	19758	13768	
ESRMD-54-620-F30	680	3	3.49	37	25875	22129	17205	11627
ESRMD-54-429-F50	680	5	5.70	44	32002	28710	24070	19075
ESRMD-54-614-C50	870	5	5.75	58	32687	30673	28684	26153
ESRMD-54-422-C75	870	7½	8.39	60	37995	35786	33443	30137
ESRMD-54-624-C100	870	10	11.92	63	42762	40340	38331	35529

Shading indicates sound levels in excess of 50 sones (85 dBA) and are subject to OSHA regulations.

Model Number Code

The model numbering system is designed to completely identify the fan. The correct code letters and numbers must be specified to designate function, size, no. of blades, pitch, RPM & HP.

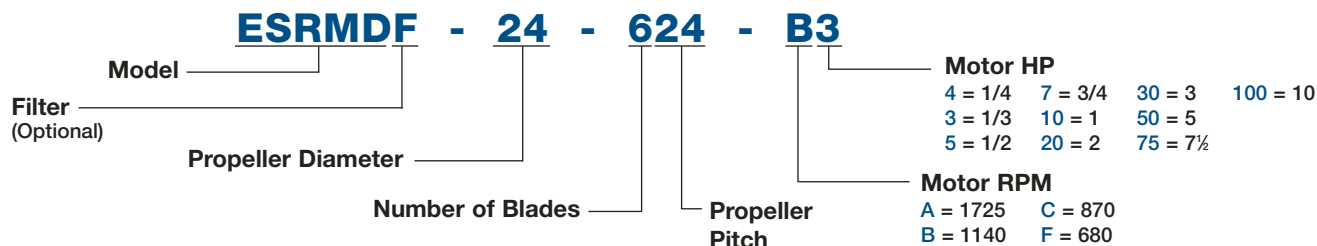

Dimensional Data

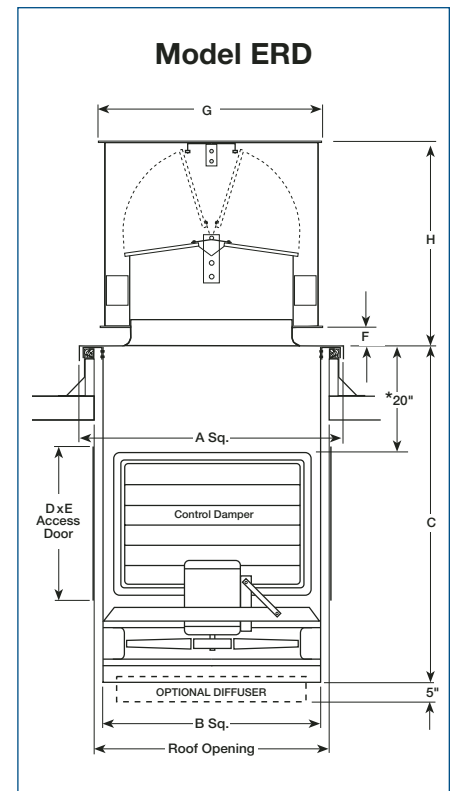
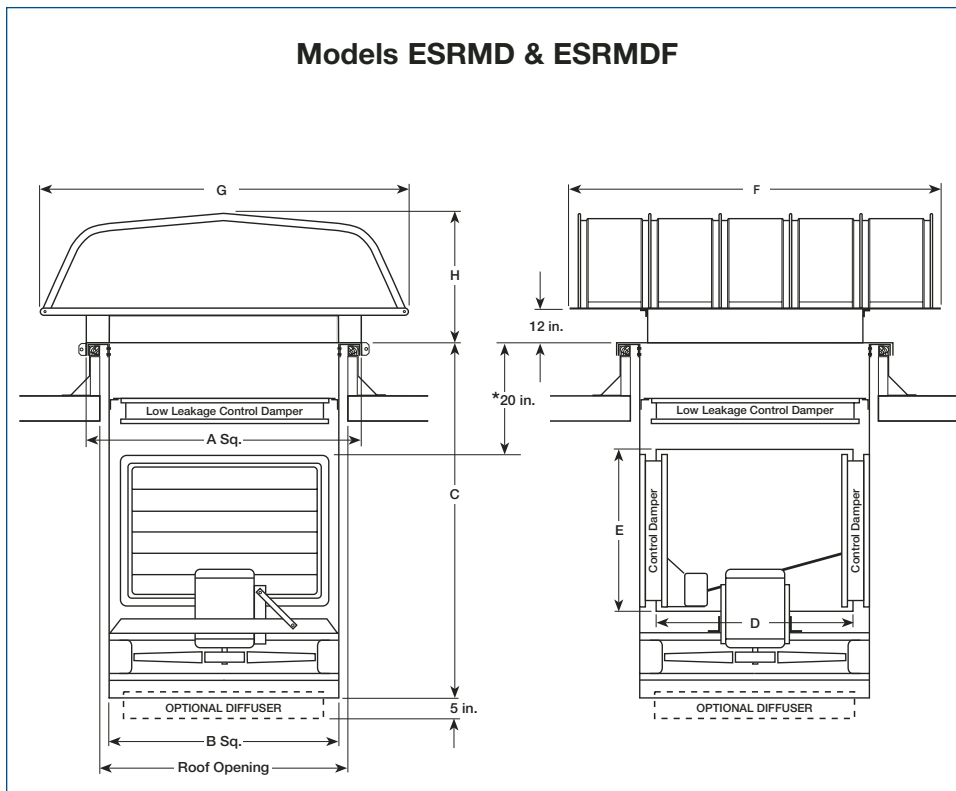

Important: Plenum height can be increased in 12 in. increments (to clear solid ceiling obstructions, etc.) Increases will effect dimension C. See page 4 for more information on plenum height.

Size	A	B	C*	Top Damper VCD-2120	Recirc. Damper VCD-1020	Access Doors		Roof Opening
						D	E	
24	40	32	58½	29 x 29	27w x 26h	21	20	34½
30	46	38	63	35 x 35	33w x 30h	27	20	40½
36	52	44	71¾	41 x 41	39w x 38h	33	22	46½
42	58	50	75¾	47 x 47	44w x 42h	38	36	52½
48	64	56	82¾	53 x 53	50w x 48h	44	36	58½
54	70	62	91	59 x 59	56w x 54h	50	36	64½

Size	Non-Filtered Hood			Filtered Hood			Upblast Hood			Approximate Unit Weights					
	ESRMD Hood Size			ESRMDF Hood Size			ERD Hood Size			ESRDM		ESRMDF		ERD	
	F	G	H	F	G	H	F	G	H	Alum	Galv	Alum	Galv	Alum	Galv
24	63	66	30	63	66	30	2½	31¾	26¼	570	650	670	750	400	480
30	75	74	32	75	78	32	3½	37¾	30¾	760	900	860	1000	490	630
36	87	76	33	87	94	33	4½	43¾	33¾	1040	1200	1170	1330	715	875
42	99	86	36½	99	100	36½	4½	50	38½	1200	1400	1330	1530	850	1050
48	111	100	36½	111	112	36½	5½	56¼	41	1470	1700	1620	1850	1110	1340
54	111	112	39	112	124	39	5½	63¾	45	1770	2000	1920	2150	1405	1635

All dimensions are in inches.

Due to Greenheck's policy of continuous product improvement, dimensions are subject to change without notice. For complete dimensional information refer to the applicable submittals for this product.

Typical Specifications

All exhaust, supply, recirculating and modulating power roof ventilators shall be direct drive axial type. Propeller construction shall be cast aluminum, airfoil, reversible design. Propellers shall be statically and dynamically balanced.

Fan hood and base construction shall be galvanized steel (aluminum optional). Bases shall be 12 in. high. Hood panels shall be arched with interlocking seams for weather protection. Birdscreens constructed of 1/2 in. galvanized steel mesh shall be mounted horizontally across the discharge/intake area of the hood. Hood support members shall be heavy gauge galvanized steel angles.

Plenums shall be constructed of galvanized steel (painted

steel optional). Plenum mounting channels shall be heavy gauge galvanized steel. Access panels shall be provided in each of two opposing sides of the plenum.

Dampers shall be constructed with galvanized steel frames and blades. Exhaust/ supply dampers shall be Greenheck model VCD 2120 low leakage control dampers. Recirculation dampers shall be Greenheck model VCD 1020 control dampers. Damper actuators for exhaust, supply and recirculation fans shall be modulating type with spring returns.

Motors shall be heavy duty ball bearing type carefully matched to the fan load and furnished at the specified voltage, phase and enclosure. A standard square key and set screws or tapered lock

bushing shall attach the propeller securely to the motor shaft.

Motor support frame assemblies shall be constructed of heavy gauge steel angles. Fan panels shall be heavy gauge steel with formed flanges and a double venturi.

Performance shall be equal for exhaust, supply and recirculate modes.

Each unit shall bear a permanently affixed nametag with a fan model number, a serial number, and a mark. Optional control centers shall bear a nametag with identical information.

Hooded axial roof ventilators shall be direct drive model ESRMD (Four-Way Fan) as manufactured by Greenheck, Schofield, Wisconsin.



Building Value in Air

Greenheck delivers value to mechanical engineers by helping them solve virtually any air quality challenges their clients face with a comprehensive selection of top

quality, innovative air-related equipment. We offer extra value to contractors by providing easy-to-install, competitively priced, reliable products that arrive on time. And building

owners and occupants value the energy efficiency, low maintenance and quiet dependable operation they experience long after the construction project ends.

Our Warranty

Greenheck warrants this equipment to be free from defects in material and workmanship for a period of one year from the purchase date. Any units or parts which prove defective during the warranty period will be replaced at our option when returned to our factory, transportation prepaid. Motors are warranted by the motor manufacturer for a period of one year. Should motors furnished by Greenheck prove defective during this period, they should be returned to the nearest authorized motor service station. Greenheck will not be responsible for any removal or installation costs.

As a result of our commitment to continuous improvement, Greenheck reserves the right to change specifications without notice.

