

Direct Gas-Fired Heating

Model DG

- 800 to 15,000 cfm
- Up to 1,600,000 BTU/hr

Optional Evaporative Cooling



Model DG

Direct Gas-Fired Make-Up Air Unit

The Greenheck model DG is a 100% efficient direct gas-fired make-up air unit. Evaporative cooling is also available for combination heating and cooling requirements.

The DG is designed to provide make-up air to commercial and industrial facilities with process exhaust. Air flow volumes range from 800 to 15,000 cfm with heating capacities up to 1,600,000 BTU/hr.



Durable Construction

Designed for maximum weather resistance, DG housings are constructed of heavy gauge G90 galvanized steel. Lifting lugs are standard.

Direct Gas-Fired System

Greenheck's direct gas-fired make-up air units feature:

- High quality cast aluminum burners with stainless steel mixing plates
- Maxitrol burner modulation control
- Flame safeguard with digital fault indicator capability (over 400,000 BTU/Hr)
- 25:1 turn down ratio

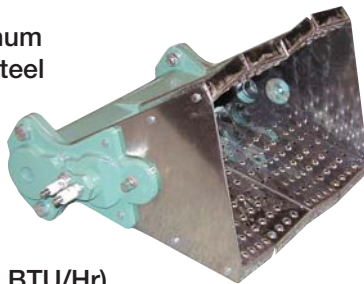

Control Center

The control center includes the following standard components:

- Magnetic motor starter with solid state overload protection
- Control transformer with fusing
- Integral door interlocking disconnect switch
- Distribution terminal strip

Premium grade control components are selected for reliable operation. All electrical components are UL Listed, recognized or classified and factory prewired for single point power connection.



Vibration Isolators

The entire fan and motor assembly is mounted on vibration isolators to minimize noise transmission into the building.



Reliable Fan Performance

Air performance ratings from Greenheck's AMCA registered test chamber ensure accurate data.



Double width, double inlet, forward curved wheels for high efficiency and low sound levels are constructed of heavy gauge steel. Wheels are statically and dynamically balanced to ensure vibration free operation.

Access Panels

Large access panels are provided for easy inspection and maintenance of motors, drives, fan wheels, filters, and heater controls.

Factory Wired and Tested

All units are tested prior to shipment. Units are checked for proper operation of the gas train, electrical components and airflow.



Stand Alone Arrangements

The model DG is available for stand alone installations with a downblast (Arrangement DB) or horizontal (Arrangement HZ) discharge.

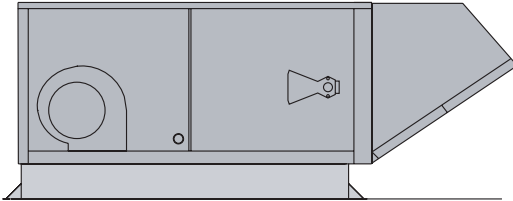

Downblast Discharge - Arrangement DB

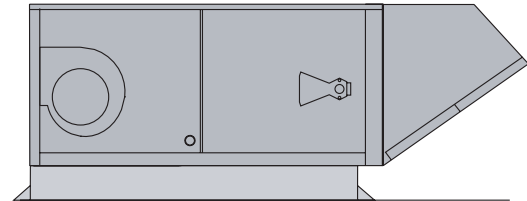

Horizontal Discharge - Arrangement HZ

Combination Packages

The Greenheck combination package simplifies installation and reduces field labor costs. The pre-engineered design ensures that the supply fan, exhaust fan, curb, and combination extension components interface properly for kitchen ventilation applications.

Equally important, Greenheck combination packages are specifically designed to comply with NFPA 96.

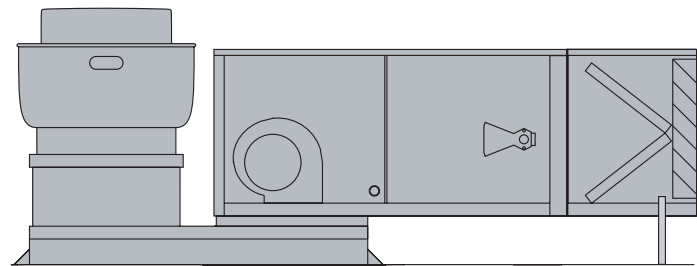

Combination Package - Arrangement DBC

NFPA 96 states:

- Exhaust duct must terminate at least 24 inches above the roof deck
- Fan discharge must be at least 40 inches above the roof deck
- Air intake shall have a horizontal separation of 10 feet from the exhaust discharge

Note: Consult local codes and the authority having jurisdiction if there are questions concerning the use of this product.

The combination curb extension is the component that pulls the Combination Package together, providing a factory engineered interface between the roof curb and the fans.

With a standard 12 inch roof curb, louvered weatherhood, and Greenheck Model CUBE exhaust fan, the combination curb extension will ensure compliance to the above NFPA 96 requirements.

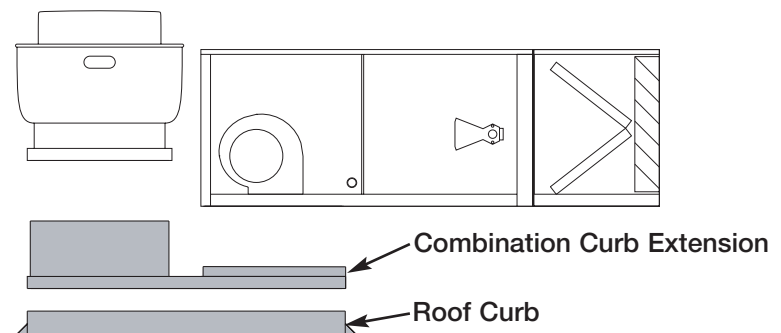

Evaporative Cooling



The optional evaporative cooling section includes a galvanized steel housing with a louvered intake, 2 inch aluminum mesh filters and a stainless steel evaporative cooling module. The evaporative cooling media is Munters GLASdek and has a depth of 12 inches for 90% cooling effectiveness.

The entire section mounts directly to the front of the DG unit, eliminating transition or ductwork by others. Drain and overflow are conveniently tapped through the side of the cooling section. The supply line connection is field located where convenient. Freeze protection, automatic drain & fill and the Water Wizard™ evaporative optimizer are also available.

Configuration & Installation Accessories

Weatherhoods

Birdscreen, louvered or filtered weatherhoods with standard G90 galvanized steel construction are available.



The birdscreen weatherhood features a wire mesh intake, which prevents large debris from damaging the filters. An additional filter section is required.



The filtered weatherhood includes aluminum mesh filters mounted in the intake, eliminating the need for an additional filter section.



The louvered weatherhood includes a louvered intake and aluminum mesh filters in a compact design that requires no additional filter section.

V-Bank Filter Section

A V-bank filter section is standard on units with a birdscreen weatherhood. Specify either 2 inch washable aluminum mesh filters or 2 inch disposable filters.

Duct Adapter

Provides easy means for attaching ductwork to curb and allows installation of top section of duct prior to setting the unit on the curb.

Roof Curb

Factory provided roof curbs are available to ensure compatibility between the make-up air unit and roof curb. Standard construction is G90 galvanized steel and includes 1 inch insulation.

Discharge Damper

A discharge damper prevents both backdrafts when the fan is not in operation and condensation inside the unit during cold weather conditions. A wide variety of backdraft and control dampers are available for field installation.

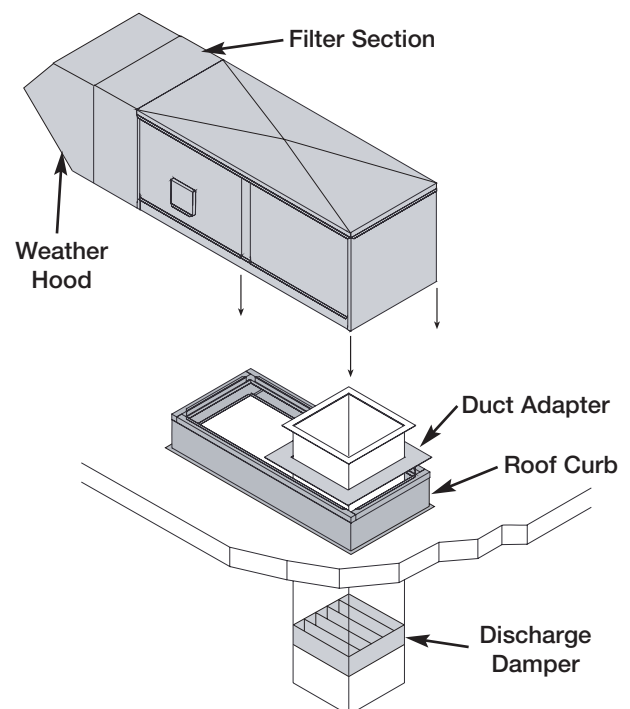

Remote Control Panels

A wide variety of remote control panels are available. Specify the desired combination of switches, thermostats, temperature selectors and indicator lights. Keyed switching is also available. Number-to-number wiring between the make-up air unit and the remote panel simplify required field wiring.



Temperature Controls

Discharge Temperature Control

Control of discharge air temperature is accomplished with a factory installed sensor located at the fan discharge. A Maxitrol 14 system modulates the gas valve to provide the desired discharge temperature.

Room Override

The room override option, available with the Maxitrol 14 system, boosts the discharge temperature when the space temperature is too cool. Discharge sensor is factory installed. Room sensor may be wall/beam mounted or included on a remote control panel.



Room Temperature Control

Specify this option when the DG has the primary responsibility of controlling the room temperature. A room mounted thermostat senses the room temperature and provides feedback to the Maxitrol 44 control system which modulates to satisfy the room temperature setting.



The thermostat is manually adjustable to the desired room temperature. The room thermostat may be wall/beam mounted or included on a remote control panel.

Optional Accessories

Exhaust Fan Starter(s)

Up to 2 exhaust fan starters may be added to the make-up air control center.

Air Filter Gauge

Indicates when filters become dirty. An indicator light may be wall/beam mounted or provided with a remote control panel.

Intake Dampers

Motorized intake dampers are available to prevent backdrafts when the fan is not in operation. Intake dampers are factory mounted and wired.

Fiberglass Insulation

One inch fiberglass insulation is used to line the housing, preventing the formation of condensation and forming an acoustical barrier.

Freeze Protection

An on/off discharge duct stat (with a timer) prevents the discharge of cold air into the building if the burner is not providing adequate tempering.

Double Wall Construction

An interior metal liner is available to isolate insulation from the airstream. Fiberglass insulation is included with this option.

Propane Gas

A propane heater may be provided in lieu of natural gas.

Inlet Air Sensor

An on/off type duct stat automatically de-energizes the gas system and interrupts the flow of gas to the burner when the inlet air temperature is above the desired setting.

Gas Pressure Regulator

Required if building gas line pressure exceeds the maximum inlet gas pressure of the make-up air unit. Ships separately for field installation.

Special Coatings

Greenheck's Permatecor coating is available for a durable, long lasting finish. Decorative paints are also available in a variety of colors to match existing building fixtures. Consult your Greenheck representative for paint selections.

115 Volt GFCI Service Receptacle

A 115 volt GFCI outlet is mounted externally in a NEMA 3R box for the convenience of field service personnel. A separate 115 volt power source is required.

Housing 10

MODEL	CFM		TOTAL STATIC PRESSURE in inches of WG						Maximum MBH
			0.75	1.00	1.25	1.50	1.75	2.00	
DG-108	800	RPM	1109	1216	1311	1399			120
		BHP	0.26	0.31	0.35	0.40			
	1,000	RPM	1228	1325	1415	1500	1579		150
		BHP	0.41	0.47	0.53	0.59	0.65		
	1,200	RPM	1347	1445	1530				180
		BHP	0.59	0.68	0.75				
DG-109	1,500	RPM	1014	1140	1255	1361	1460		225
		BHP	0.45	0.54	0.63	0.73	0.84		
	1,950	RPM	1102	1210	1312	1411	1504		295
		BHP	0.73	0.86	0.97	1.1	1.2		
	2,400	RPM	1216	1306	1397	1484			365
		BHP	1.1	1.3	1.4	1.6			
DG-110	2,000	RPM	912	1013	1110	1199			305
		BHP	0.59	0.71	.084	.096			
	2,500	RPM	995	1082	1166	1247	1325		380
		BHP	0.93	1.1	1.2	1.4	1.5		
	3,000	RPM	1097	1172	1244	1315	1386		400
		BHP	1.4	1.6	1.7	1.9	2.1		

Housing 20

MODEL	CFM		TOTAL STATIC PRESSURE in inches of WG						Maximum MBH
			0.75	1.00	1.25	1.50	1.75	2.00	
DG-112	2,600	RPM	761	853	934	1009			395
		BHP	0.7	0.9	1.0	1.2			
	3,500	RPM	839	920	993	1065	1133	1195	530
		BHP	1.3	1.5	1.7	1.9	2.1	2.3	
	4,400	RPM	939	1006	1073	1137	1197		670
		BHP	2.1	2.4	2.6	2.9	3.1		
DG-115	4,000	RPM	681	756	822	892			610
		BHP	1.3	1.5	1.8	2.1			
	5,250	RPM	757	823	884	943	998	1049	800
		BHP	2.2	2.5	2.8	3.2	3.5	3.8	
	6,500	RPM	850	906	960	1013	1062		800
		BHP	3.5	3.9	4.3	4.7	5.1		

Housing 30

MODEL	CFM		TOTAL STATIC PRESSURE in inches of WG						Maximum MBH
			0.75	1.00	1.25	1.50	1.75	2.00	
DG-118	6,500	RPM	609	668	724	777			990
		BHP	2.1	2.5	2.8	3.2			
	8,000	RPM	668	721	772	819	864	910	1220
		BHP	3.3	3.7	4.2	4.6	5.0	5.5	
	9,500	RPM	736	783	827	872	914		1450
		BHP	4.9	5.4	5.9	6.4	6.9		
DG-120	10,000	RPM	590	634	678	723	765	803	1525
		BHP	4.0	4.5	5.0	5.6	6.1	6.6	
	12,500	RPM	672	711	748	784	820	855	1600
		BHP	6.9	7.5	8.1	8.7	9.3	10.0	
	15,000	RPM	763	795	829	861	892	921	1600
		BHP	10.9	11.6	12.3	13.1	13.8	14.5	

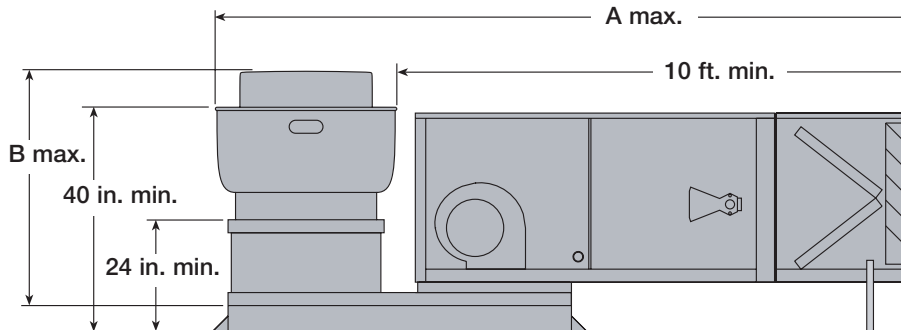
Combination Package

Housing Size	A*	B*	Width
H10	159½	47	35½
H20	172¾	57¾	50
H30	199	63¾	58¾

All dimensions are shown in inches.
 *Based on largest available CUBE exhaust fan.

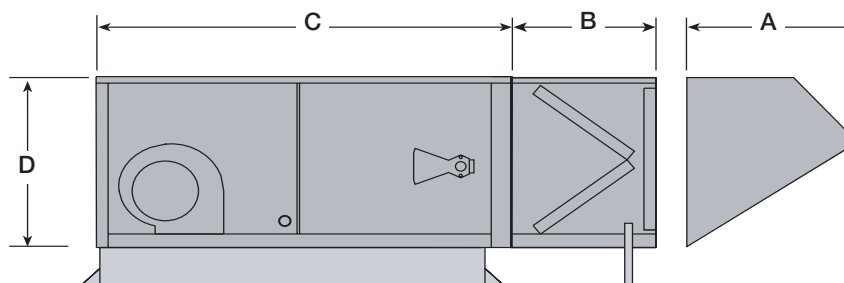
Stand Alone

Housing Size	A			B*	C	D	Width
	Filtered	Louvered	Birdscreen*				
H10	31¾	27½	26¼	27¾	78¼	33¾	28
H20	34¾	30¼	32¼	30¼	86¼	33¾	37
H30	65¾	33¾	28¼	33	101¼	42½	48

All dimensions are shown in inches.
 *The birdscreen weatherhood requires an additional filter section. The additional filter section is optional with the filtered or louvered weatherhood.

General: Make-up air unit shall be as manufactured by Greenheck or approved equal provided all specifications are met. Greenheck Model DG equipment is used as the basis of design. Performance to be as scheduled on plans. Make-up air unit shall be ETL listed to ANSI Z83.4 and CAN 3.7.

Gas Train and Controls: Direct fired gas system shall have a draw through design and field adjustable burner baffles. Gas trains up to 400,000 Btu/hr shall include a direct spark ignition system. Gas trains greater than 400,000 Btu/hr shall include a pilot ignition system and shall have digital coded fault indicator capability. Fault indicator shall provide service history by storing codes for the last five faults. Dual safety shutoff valves shall be industrial duty and use 120 VAC control signals. Temperature control shall incorporate a Maxitrol electronic modulation control system.

Unit Casing and Frames: Unit shall be of internal frame type construction of galvanized steel. All frames and panels shall be G90 galvanized steel. Where top panels are joined there shall be a standing seam to insure positive weather protection. All metal-to-metal surfaces exposed to the weather shall be sealed. All components shall be easily accessible through removable or hinged doors.

Optional Insulation: Unit casing to be lined with 1 inch fiberglass insulation. Insulation in accordance with NFPA 90A and tested to meet UL 181 erosion requirements and secured to unit with water proof adhesive and permanent mechanical fasteners. Double wall construction is optional.

Fan Section: Centrifugal fans shall be double width, double inlet and forward curved. Fan and motor shall be mounted on a common base and shall be internally isolated. All blower wheels shall be statically and dynamically balanced. Ground and polished steel fan shafts shall be mounted in

permanently lubricated ball bearings (up to size 118) or ball bearing pillow blocks (size 120 and larger). Bearings shall be selected for a minimum (L10) life in excess of 100,000 hours at maximum cataloged speeds.

Motors and Drives: Motors shall be energy efficient, complying with EPACT standards for ODP and TE enclosures. Motors shall be permanently lubricated, heavy duty type, matched to the fan load and furnished at the specified voltage, phase and enclosure. Drives shall be sized for a minimum of 150% of driven horsepower. Pulleys shall be cast and have machined surfaces, 15 horse power and less shall be supplied with an adjustable drive pulley.

Electrical: All internal electrical components shall be prewired for single point power connection. All electrical components shall be UL listed, recognized or classified where applicable and wired in compliance with the National Electrical Code. Control center shall include motor starter, control circuit fusing, control transformer for 24 VAC circuit and integral door interlocking disconnect switch. Contactors, Class 20 adjustable overload protection and single phase protection shall be standard.

V-Bank Filter Section: Filters shall be mounted in a V-bank arrangement such that velocities across the filters do not exceed 550 feet per minute. Filters shall be easily accessible through a removable access panel.

Weather Hood: Weather hood shall be constructed of G90 galvanized steel.

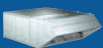
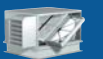

Our Warranty

Greenheck warrants this equipment to be free from defects in material and workmanship for a period of one year from the purchase date. Any units or parts which prove defective during the warranty period will be replaced at our option when returned to our factory, transportation prepaid. Motors are warranted by the motor manufacturer for a period of one year. Should motors furnished by Greenheck prove defective during this period, they should be returned to the nearest authorized motor service station. Greenheck will not be responsible for any removal or installation costs.

As a result of our commitment to continuous improvement, Greenheck reserves the right to change specifications without notice.

Greenheck P.O. Box 410 • Schofield, WI 54476-0410 • Phone (715) 359-6171 • greenheck.com