

# Inline & Sidewall Exhaust Fans



BCF



BDF

UL/cUL 705 Power Ventilators  
E40001 - BCF with TEFC motors  
E40001 - BDF with TEFC motors



Model BCF is AMCA Licensed for Air Performance  
Model BDF is AMCA Licensed for Sound and Air Performance

28

**Best Available Program**

3 Days

## Model BCF and BDF Belt Drive

Centrifugal duct fans are designed for clean air inline exhaust or supply applications.

### Quick Build Performance

BCF capacities range from 200 to 6,000 cfm and 1.5 in. wg of static pressure.  
BDF capacities range from 300 to 15,000 cfm and 3 in. wg of static pressure.

Standard Construction	BCF	BDF
Housing - galvanized steel	■	■
Housing - low profile	■	
Housing - square		■
Drive frame secured to housing	■	■
Wheel - forward-curved, galvanized steel	■	■
Motor and scroll - mounted to drive frame	■	■
Access door - bolted, removable (BCF-108/208 and larger, all BDF)	■	■
Access door - hinged (BCF-106, 107, 206 and 207)	■	■
Corrosion-resistant fasteners	■	■
NEMA-1 disconnect switch	■	■
Ball bearing motor - 1/4 hp and larger	■	■
Double-studded vibration isolators	■	■
Flanges - inlet and outlet	■	■
Adjustable motor pulley	■	■
Options and Accessories	BCF	BDF
Damper	■	■
Isolators	■	■
Insulation	■	■
Filter box* - filters are throwaway (pleated) or permanent (aluminum mesh)	■	■
Mixing box	■	
NEMA rated disconnect switch	■	■
Dual drives	■	■
Multiple discharge positions*	■	■
Decorative or protective powder coating	■	■
UL/cUL Listed Power Ventilators	■	■

\*see page 31 for additional information

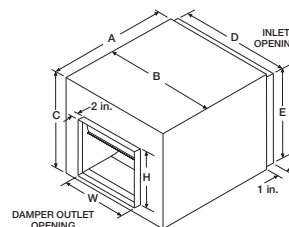
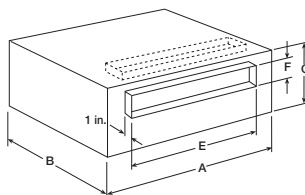

### Dimensions for BCF

Top horizontal discharge

Model Size	A	B	C	E	F
106	20	23 <sup>3</sup> / <sub>4</sub>	11	12	6
107	23	29	13	15	8
108	26	32	16	18	10
110	32	36	19	24	12
112	36	42	23	28	14
206	34	23 <sup>3</sup> / <sub>4</sub>	11	26	6
207	38	29	13	30	8
208	44	32	16	36	10
210	48	36	19	40	12
212	58	42	23	50	14

All dimensions are in inches.

### Dimensions for BDF

Bottom horizontal discharge

Model Size	A	B	C	Damper Outlet Opening (W x H)	Inlet Opening (D x E)
80	23 <sup>3</sup> / <sub>4</sub>	18 <sup>1</sup> / <sub>2</sub>	15 <sup>5</sup> / <sub>8</sub>	9 <sup>3</sup> / <sub>4</sub> x 8 <sup>7</sup> / <sub>8</sub>	15 <sup>3</sup> / <sub>16</sub> x 12 <sup>11</sup> / <sub>16</sub>
90	24 <sup>1</sup> / <sub>4</sub>	21 <sup>1</sup> / <sub>4</sub>	18 <sup>3</sup> / <sub>4</sub>	12 <sup>1</sup> / <sub>4</sub> x 10 <sup>1</sup> / <sub>2</sub>	18 <sup>1</sup> / <sub>4</sub> x 15 <sup>7</sup> / <sub>8</sub>
100	26 <sup>1</sup> / <sub>4</sub>	22 <sup>3</sup> / <sub>4</sub>	20 <sup>3</sup> / <sub>4</sub>	13 <sup>3</sup> / <sub>4</sub> x 11 <sup>5</sup> / <sub>8</sub>	19 <sup>3</sup> / <sub>4</sub> x 17 <sup>7</sup> / <sub>8</sub>
120	33	27 <sup>1</sup> / <sub>4</sub>	22 <sup>3</sup> / <sub>4</sub>	16 x 13 <sup>3</sup> / <sub>8</sub>	24 <sup>1</sup> / <sub>8</sub> x 19 <sup>7</sup> / <sub>8</sub>
150	34 <sup>3</sup> / <sub>4</sub>	32 <sup>5</sup> / <sub>8</sub>	27 <sup>3</sup> / <sub>4</sub>	19 <sup>1</sup> / <sub>8</sub> x 16 <sup>3</sup> / <sub>8</sub>	28 <sup>5</sup> / <sub>8</sub> x 23 <sup>7</sup> / <sub>8</sub>
180	40 <sup>1</sup> / <sub>4</sub>	41 <sup>3</sup> / <sub>4</sub>	31 <sup>3</sup> / <sub>4</sub>	22 <sup>1</sup> / <sub>2</sub> x 18 <sup>7</sup> / <sub>8</sub>	37 <sup>1</sup> / <sub>2</sub> x 27 <sup>7</sup> / <sub>8</sub>
200	50 <sup>1</sup> / <sub>4</sub>	49 <sup>1</sup> / <sub>4</sub>	39 <sup>3</sup> / <sub>4</sub>	23 <sup>1</sup> / <sub>8</sub> x 25 <sup>1</sup> / <sub>4</sub>	45 <sup>1</sup> / <sub>8</sub> x 36

All dimensions are in inches.

BSQ



SQ

## Model SQ Direct Drive and BSQ Belt Drive

Centrifugal inline fans are designed for clean air exhaust or supply applications.

### Quick Delivery / Quick Build Performance

SQ capacities range from 80 to 5,025 cfm and 1.75 in. wg of static pressure. BSQ capacities range from 60 to 26,600 cfm and 4 in. wg of static pressure.



UL/cUL Listed 705 is standard on In Stock models.

Model SQ and BSQ are AMCA Licensed for Sound and Air Performance

Model	Best Available Program
SQ-75 through 120 and 140 BSQ-70 through 120, 140 through 180 and 240	In Stock
SQ-60 through 70, 130 thru 160 High Pressure SQ-130HP through 160HP BSQ-130 and 200	1 Day
High Pressure BSQ-130HP through 240HP BSQ-300 through 420 High Pressure BSQ-300HP and 360HP	3 Days

Standard Construction	SQ	BSQ	
Housing - galvanized	■	■	
Wheel - backward-inclined, aluminum	■	■	
Access panel - bolted, removable	■	■	
Corrosion-resistant fasteners	■	■	
NEMA-1 disconnect switch	■	■	
Ball bearing motor - 1/4 hp and larger	■	■	
Three speed motor - sizes 60 through 95	■		
Adjustable motor plate		■	
Flanges - inlet and outlet	■	■	
Adjustable motor pulley		■	
Options and Accessories	Stock	SQ	BSQ
Vari-Green® motor - 80% turndown, 85% efficient <i>Available as standard on select sizes</i>	✓	■	
Damper	✓	■	■
Aluminum housing		■	■
Motor cover		■	■
Guards - inlet, outlet		■	■
Speed control	✓	■	
Isolators - external	✓	■	■
Insulation - housing and motor cover		■	■
Filter box* - slide out		■	■
NEMA rated disconnect switch		■	■
Dual drives			■
Relubricatable bearings			■
Multiple discharge positions*		■	■
Decorative or protective powder coating		■	■
UL/cUL Listed Power Ventilators		■	■

\*see page 31 for additional information

### Dimensions for SQ

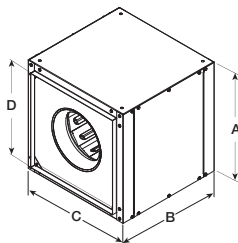

Model Size	A & C	B	D
60, 65, 70, 75	12	13	8 <sup>7</sup> / <sub>8</sub>
80, 85, 90 95	15	16	11 <sup>7</sup> / <sub>8</sub>
97, 98, 99	15	21	11 <sup>7</sup> / <sub>8</sub>
100	17	21	13 <sup>3</sup> / <sub>8</sub>
120	19	21	15 <sup>7</sup> / <sub>8</sub>
130, 130 HP	21	21	17 <sup>7</sup> / <sub>8</sub>
140, 140 HP	23	22	19 <sup>7</sup> / <sub>8</sub>
160, 160 HP	26	26	22 <sup>7</sup> / <sub>8</sub>

All dimensions are in inches.

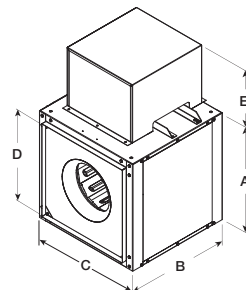

### Dimensions for BSQ

Model Size	A & C	B	D	H*
70, 80, 90	17 <sup>7</sup> / <sub>8</sub>	21	11 <sup>7</sup> / <sub>8</sub>	13 <sup>1</sup> / <sub>4</sub>
100	17 <sup>7</sup> / <sub>8</sub>	21	13 <sup>3</sup> / <sub>8</sub>	13 <sup>1</sup> / <sub>4</sub>
120	19 <sup>7</sup> / <sub>8</sub>	21	15 <sup>7</sup> / <sub>8</sub>	13 <sup>1</sup> / <sub>4</sub>
130, 130 HP	21 <sup>7</sup> / <sub>8</sub>	21	17 <sup>7</sup> / <sub>8</sub>	13 <sup>1</sup> / <sub>4</sub>
140, 140 HP	23 <sup>7</sup> / <sub>8</sub>	22	19 <sup>7</sup> / <sub>8</sub>	13 <sup>1</sup> / <sub>4</sub>
160, 160 HP	26 <sup>7</sup> / <sub>8</sub>	26	22 <sup>7</sup> / <sub>8</sub>	13 <sup>1</sup> / <sub>4</sub>
180, 180 HP	27 <sup>7</sup> / <sub>8</sub>	28	23 <sup>3</sup> / <sub>8</sub>	13 <sup>1</sup> / <sub>4</sub>
200, 200 HP	31 <sup>7</sup> / <sub>8</sub>	32	27 <sup>7</sup> / <sub>8</sub>	16
240, 240 HP	38 <sup>7</sup> / <sub>8</sub>	34	34 <sup>7</sup> / <sub>8</sub>	16
300, 300 HP	46	38	41 <sup>7</sup> / <sub>8</sub>	18
360, 360 HP	52	42	47 <sup>7</sup> / <sub>8</sub>	18
420	58	50	53 <sup>7</sup> / <sub>8</sub>	18

All dimensions are in inches.

\*Dimension may be greater depending on motor



Select sizes and models with the Vari-Green® motor are available in stock.

## SQ and BSQ Options and Accessories

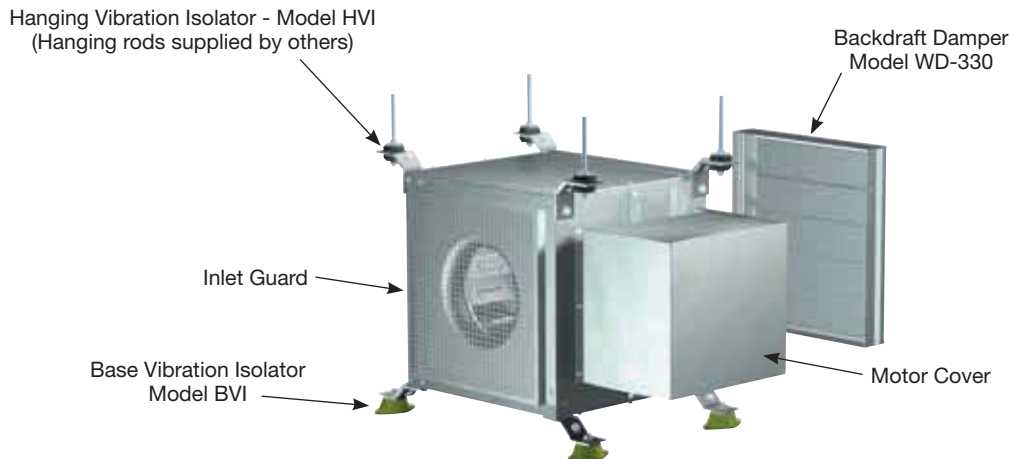

### Side Discharge

The side discharge option provides several advantages from removing a system effect problem, to increasing performance and even reducing installation labor.

The most notable is reducing system effect. Refer to Figure 1. It shows the air being discharged into the corner. It will take several duct lengths before the airflow becomes laminar or smooth again after making the turn.

In Figure 2, the fan is placed in the corner using a side discharge. In this configuration the airflow pattern at discharge is smooth and supports a more predictable system. Remember the duct length on the discharge side should be approximately two to three wheel diameters to achieve catalog performance.

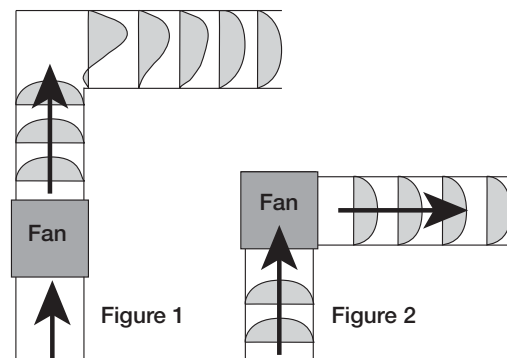









### Multiple Discharge Positions

BCF fans are available with either top horizontal or upblast discharge positions.

BDF fans have been designed for horizontal mounting and are standard with a bottom horizontal discharge. Optional top horizontal discharge is also available.

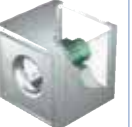
SQ and BSQ fans are available with right side discharge, left side discharge, inline discharge positions, or a combination of right, left and inline positions.

BCF Discharge Positions		BDF Discharge Positions	
Top Horizontal	Upblast	Bottom Horizontal	Top Horizontal
			
SQ and BSQ Discharge Positions			
Right Side	Left Side	Inline	Combination
			

## Filter Box

Filter boxes incorporate a V-bank design constructed of galvanized steel. Filters are available in 1 or 2 inch throwaway (pleated) or permanent (washable aluminum mesh). Side access panels are standard for easy maintenance.



Slanted Filter



Double V-Bank Filter



Aluminum Mesh Filter

### BDF

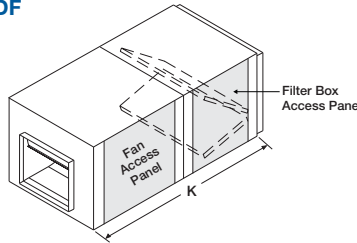

Model Size	K	Filter Size	No. of Filters
80	49 <sup>3</sup> / <sub>8</sub>	16 x 20	2
90	54 <sup>7</sup> / <sub>8</sub>	20 x 25	2
100	51 <sup>1</sup> / <sub>8</sub>	20 x 20	2
120	63 <sup>3</sup> / <sub>16</sub>	12 x 25	4
150	62 <sup>1</sup> / <sub>16</sub>	16 x 20	8
180	75 <sup>3</sup> / <sub>8</sub>	20 x 25	6
200	85 <sup>1</sup> / <sub>4</sub>	16 x 25	12

### BCF

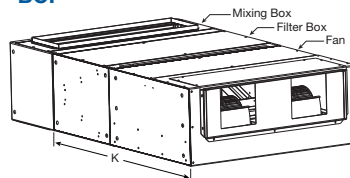

Model Size		K	Filter Size		No. of Filters	
Single Fan	Double Fan		Single Fan	Double Fan	Single Fan	Double Fan
106	206	45 <sup>1</sup> / <sub>2</sub>	16 x 20	20 x 20	1	1
107	207	52	16 x 20	16 x 20	1	2
108	208	56	16 x 20	16 x 20	2	4
110	210	61	20 x 20	20 x 20	2	4
112	212	65	16 x 20	20 x 25	4	4

For slide-out filter box information, refer to BCF catalog.

### SQ, BSQ

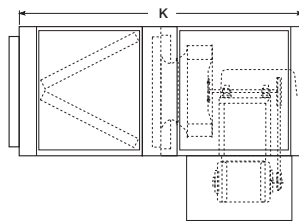

SQ			
Model Size	K	Filter Size	No. of Filters
60, 65, 70, 75	22 <sup>1</sup> / <sub>8</sub>	10 x 12	1
80, 95, 90, 95	45 <sup>5</sup> / <sub>8</sub>	14 x 25	1
97, 98, 99	50 <sup>5</sup> / <sub>8</sub>	14 x 25	1
100	47 <sup>1</sup> / <sub>4</sub>	16 x 20	2
120	52 <sup>3</sup> / <sub>16</sub>	16 x 25	2
130, 130HP	46 <sup>3</sup> / <sub>8</sub>	20 x 20	2
140, 140HP	52 <sup>3</sup> / <sub>8</sub>	20 x 25	2
160, 160HP	51 <sup>3</sup> / <sub>8</sub>	20 x 20	4

BSQ			
Model Size	K	Filter Size	No. of Filters
70, 80, 90	50 <sup>5</sup> / <sub>8</sub>	14 x 25	1
100	47 <sup>1</sup> / <sub>4</sub>	16 x 20	2
120	52 <sup>3</sup> / <sub>16</sub>	16 x 25	2
130, 130HP	46 <sup>3</sup> / <sub>8</sub>	20 x 20	2
140, 140HP	52 <sup>3</sup> / <sub>8</sub>	20 x 25	2
160, 160HP	51 <sup>3</sup> / <sub>8</sub>	20 x 20	4
180, 180HP	55 <sup>1</sup> / <sub>16</sub>	20 x 25	4
200, 200HP	66 <sup>1</sup> / <sub>16</sub>	12 x 25	3
		16 x 25	3
		20 x 25	4
240, 240HP	68 <sup>7</sup> / <sub>8</sub>	16 x 25	4
		20 x 25	8
300, 300HP	72 <sup>1</sup> / <sub>8</sub>	16 x 25	10
		20 x 25	5
360, 360HP	79 <sup>1</sup> / <sub>4</sub>	16 x 25	5
		20 x 25	10
420	93 <sup>1</sup> / <sub>8</sub>	16 x 25	5
		20 x 25	10

## Insulated Housing

The interior of the fan housing and filter box can be lined with a fiberglass duct liner for noise reduction and condensation control. The duct liner can be utilized to reduce radiated noise from inline fan housings. It is recommended for applications when fans are placed in acoustically sensitive locations. The duct liner also reduces the noise radiating from the inlet and outlet of the fan.





UL/cUL 705 Power Ventilators  
E40001 - TCB  
UL 762 Power Ventilators for Restaurant Exhaust  
Appliances - MH11745 - TCB



Model TCB is AMCA Licensed for Sound and Air Performance

Construction	Best Available Program
Standard	10 Days
With UL 762	15 Days

## Model TCB Belt Drive

Tubular centrifugal inline fans are the ideal choice for installations with straight-through airflow in ducted systems. The centrifugal wheels used in this design provide higher efficiencies and lower sound levels than axial type inline fans when used in medium pressure ducted systems. These fans can be mounted in any position from horizontal to vertical, allowing installation in the smallest possible space at the lowest installation cost. Also available in roof supply and roof exhaust configurations.

### Quick Build Performance

Capacities range from 300 to 26,000 cfm and up to 4.0 in. wg of static pressure.

Standard Construction	
Housing - continuously welded, steel	Spark B resistant construction
Wheel - backward-inclined, aluminum	Extended lube lines
Flanges - inlet and outlet with mounting holes	Minimum bearing life of L <sub>10</sub> 80,000 hours (Average life - L <sub>50</sub> 400,000 hours)
Universal mounting system	Perfectector™ protective powder coating
Aluminum rub ring	
Options and Accessories	
All aluminum construction	Inspection section with removable access panel
Motor cover	
Belt guard	Dual drives
Guards - inlet, outlet	Mounting rails
Companion flanges - inlet, outlet	Decorative or protective powder coating
Isolators - base, hanging	UL/cUL Listed Power Ventilators
NEMA rated disconnect switch	UL Listed Power Ventilators for Restaurant Exhaust Appliances
Easy access construction - bolted	
Inspection door - bolted, hinged	

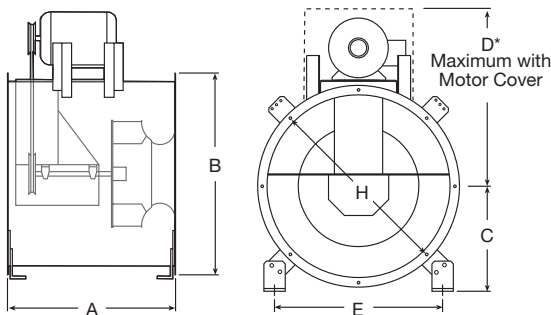

### Dimensions for TCB

Model Size	A	B	C	D*	E	H
9	23	21 <sup>5</sup> / <sub>8</sub>	13 <sup>1</sup> / <sub>4</sub>	21 <sup>3</sup> / <sub>4</sub>	17 <sup>5</sup> / <sub>8</sub>	18 <sup>3</sup> / <sub>8</sub>
10	23	21 <sup>5</sup> / <sub>8</sub>	13 <sup>1</sup> / <sub>4</sub>	21 <sup>3</sup> / <sub>4</sub>	17 <sup>5</sup> / <sub>8</sub>	18 <sup>3</sup> / <sub>8</sub>
12	23	21 <sup>5</sup> / <sub>8</sub>	13 <sup>1</sup> / <sub>4</sub>	21 <sup>3</sup> / <sub>4</sub>	17 <sup>5</sup> / <sub>8</sub>	18 <sup>3</sup> / <sub>8</sub>
13	24 <sup>1</sup> / <sub>2</sub>	23 <sup>3</sup> / <sub>8</sub>	13 <sup>7</sup> / <sub>8</sub>	23 <sup>1</sup> / <sub>4</sub>	19	20 <sup>3</sup> / <sub>8</sub>
16	28 <sup>1</sup> / <sub>2</sub>	27 <sup>5</sup> / <sub>8</sub>	16 <sup>1</sup> / <sub>8</sub>	26	21 <sup>7</sup> / <sub>8</sub>	24 <sup>3</sup> / <sub>8</sub>
18	31	33 <sup>5</sup> / <sub>8</sub>	18 <sup>3</sup> / <sub>8</sub>	29 <sup>1</sup> / <sub>4</sub>	26 <sup>5</sup> / <sub>8</sub>	30 <sup>3</sup> / <sub>8</sub>
22	35 <sup>1</sup> / <sub>2</sub>	39 <sup>5</sup> / <sub>8</sub>	22 <sup>1</sup> / <sub>2</sub>	33 <sup>3</sup> / <sub>4</sub>	30 <sup>1</sup> / <sub>2</sub>	36 <sup>3</sup> / <sub>8</sub>
24	42	45 <sup>3</sup> / <sub>4</sub>	24 <sup>5</sup> / <sub>8</sub>	37 <sup>1</sup> / <sub>4</sub>	34 <sup>3</sup> / <sub>4</sub>	42 <sup>1</sup> / <sub>2</sub>
30	48 <sup>1</sup> / <sub>2</sub>	52 <sup>3</sup> / <sub>4</sub>	29 <sup>1</sup> / <sub>2</sub>	42 <sup>3</sup> / <sub>4</sub>	42	48 <sup>1</sup> / <sub>2</sub>
36	54	59 <sup>1</sup> / <sub>4</sub>	31 <sup>3</sup> / <sub>4</sub>	47 <sup>1</sup> / <sub>4</sub>	46 <sup>3</sup> / <sub>4</sub>	55

All dimensions are in inches.  
\*Dimension may vary depending on motor.



UL/cUL 705 Power Ventilators  
E40001 - EQB



UL/cUL 705 is optional and must be specified.

Model EQB is AMCA Licensed for Sound and Air Performance

**Best Available Program**  
10 Days

## Model EQB Belt Drive

Model EQB is ideal when clean air, quiet and economical operation is required. The unique octagonal housing of formed galvanized steel panels provides for exceptional strength at significantly lower cost.

### Quick Delivery / Quick Build Performance

Capacities range from 550 to 23,000 cfm and up to 3 in. wg of static pressure.

Standard Construction
Octagonal galvanized housing
Aluminum mixed flow wheel
EZ Tension System for belt adjustment
NEMA-1 disconnect switch
Options and Accessories
Motor cover
Inlet and outlet guards
Vibration isolators
Access doors
Extended wiring pigtail
Thrust restraints
UL/cUL Listed Power Ventilators

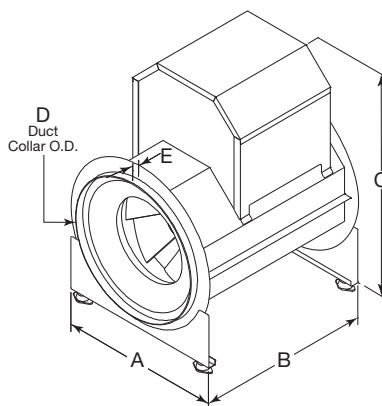

### Dimensions for EQB

Model Size	A	B	C*	D	E
9	19 <sup>3</sup> / <sub>8</sub>	22	28 <sup>3</sup> / <sub>4</sub>	14 <sup>1</sup> / <sub>4</sub>	1 <sup>3</sup> / <sub>8</sub>
12	22 <sup>5</sup> / <sub>8</sub>	26 <sup>5</sup> / <sub>8</sub>	32 <sup>3</sup> / <sub>4</sub>	17 <sup>1</sup> / <sub>2</sub>	1 <sup>1</sup> / <sub>2</sub>
15	26 <sup>3</sup> / <sub>8</sub>	29 <sup>1</sup> / <sub>8</sub>	38	21 <sup>1</sup> / <sub>8</sub>	1 <sup>1</sup> / <sub>2</sub>
16	28 <sup>1</sup> / <sub>4</sub>	31 <sup>1</sup> / <sub>8</sub>	32 <sup>3</sup> / <sub>4</sub>	17 <sup>1</sup> / <sub>2</sub>	1 <sup>1</sup> / <sub>2</sub>
18	30 <sup>7</sup> / <sub>8</sub>	33 <sup>1</sup> / <sub>8</sub>	42 <sup>5</sup> / <sub>8</sub>	25 <sup>5</sup> / <sub>8</sub>	1 <sup>1</sup> / <sub>2</sub>
20	32 <sup>7</sup> / <sub>8</sub>	35 <sup>3</sup> / <sub>4</sub>	47	28	1 <sup>3</sup> / <sub>8</sub>
22	36 <sup>3</sup> / <sub>8</sub>	39 <sup>1</sup> / <sub>4</sub>	49 <sup>5</sup> / <sub>8</sub>	31 <sup>1</sup> / <sub>4</sub>	1 <sup>3</sup> / <sub>8</sub>
24	40	42 <sup>5</sup> / <sub>8</sub>	53 <sup>1</sup> / <sub>4</sub>	34 <sup>1</sup> / <sub>4</sub>	1 <sup>3</sup> / <sub>8</sub>
27	42 <sup>7</sup> / <sub>8</sub>	45 <sup>1</sup> / <sub>8</sub>	58	37 <sup>3</sup> / <sub>4</sub>	1 <sup>3</sup> / <sub>8</sub>
30	48	52 <sup>1</sup> / <sub>4</sub>	63 <sup>5</sup> / <sub>8</sub>	42	1 <sup>7</sup> / <sub>8</sub>

\*Motor cover is optional. Size may be greater depending on motor. All dimensions are in inches.



Patented QEI  
 USA Patent No. 7048499  
 China (P.R.) Patent No. CN1294361C  
 Mexico Patent No. 243465

UL/cUL 705 Power Ventilators  
 E40001 - QEI-VII  
 UL/cUL 762 Power Ventilators for Restaurant Exhaust  
 Appliances - MH11745 - QEI-I/II  
 UL/cUL Power Ventilators for Smoke Control Systems  
 MH17511 - QEI-VII, QEID



Model QEI-I/II are AMCA Licensed for Sound and Air Performance

## Model QEI-I/II Belt Drive

Mixed flow fans are for use in commercial and industrial applications that demand quiet, efficient and reliable air movement. Typical applications include office buildings, concert halls, libraries, parking garages, educational facilities and dormitories. Models can be used in exhaust, supply, and return-air; clean or contaminated air ventilation installations with continuous airstream temperatures up to 200°F. Units may be ceiling hung or floor mounted.

### Quick Build Performance

QEI-I/II capacities range from 500 to 50,000 cfm and up to 7.5 in. wg of static pressure.

Standard Construction	
Housing - continuously welded, steel	Minimum bearing life of L <sub>10</sub> 80,000 hours (Average life - L <sub>50</sub> 400,000 hours)
Impeller - mixed flow with steel blades	
Straightening vanes	Universal mounting system (sizes 9 - 27)
Access door - bolted	Final assembly vibration analysis
Slip-fit collar for duct connection	Extended lube lines - nylon
Belt guard	Permatector™ protective powder coating
Options and Accessories	
Totally enclosed belt guard	Mounting rails - horizontal and all vertical applications
Motor cover	
Guards - inlet, outlet	Decorative or protective powder coating
Flanges - inlet, outlet	UL/cUL Listed Power Ventilators
Isolators - base, hanging	UL/cUL Listed Power Ventilators for Restaurant Exhaust Appliances
Belt tube	
NEMA rated disconnect switch	UL/cUL Listed Power Ventilators for Smoke Control Systems
Copper lube lines	

34

**Best Available Program**

10 Days

### Universal Mounting (Sizes 9-27)

Universal QEI fans can be mounted vertically (ceiling hung or base mount) for either upward or downward airflow. Optional mounting rails are suggested for any vertical installation. One configuration for base mounting or ceiling hung applications. Allows for field rotation of motor position.

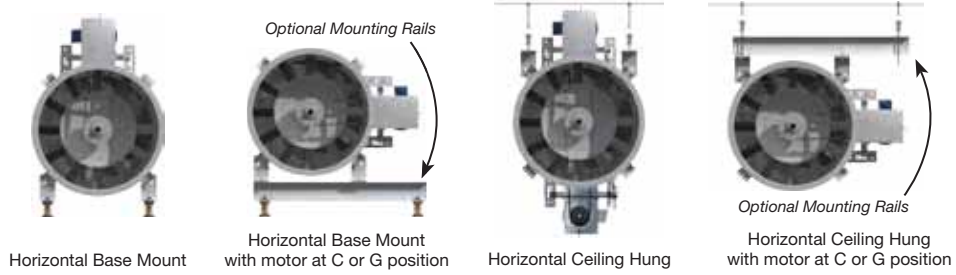

### Motor Positions

determined from the discharge end

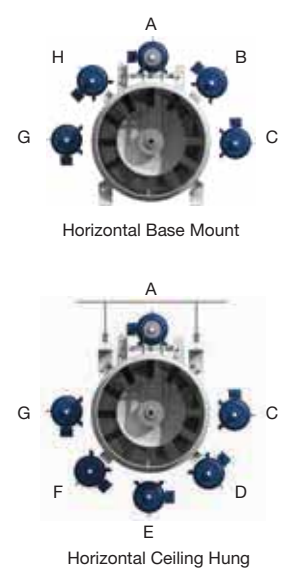

### Horizontal Mounting (Sizes 30-40)

Available in horizontal and vertical configurations. Horizontal applications allow for field rotation of motor position.

### Vertical Mounting (Sizes 9-40)

Vertical mounting configurations, upblast or downblast, are provided with heavy-duty steel brackets welded to both ends. These brackets permit either floor or ceiling mounting on the same unit. Optional mounting rails are suggested for any vertical installation for sizes 9-27.



## Mixed Flow - QEI-I/II

The mixed flow fan is a quiet, highly efficient alternative for inline ventilation. The unique axial/centrifugal hybrid impeller design captures the highly efficient “straight-through” airflow of vane axials and the lower sound levels of tubular centrifugal fans to provide an energy efficient product that won’t be a distraction in your ventilation system.

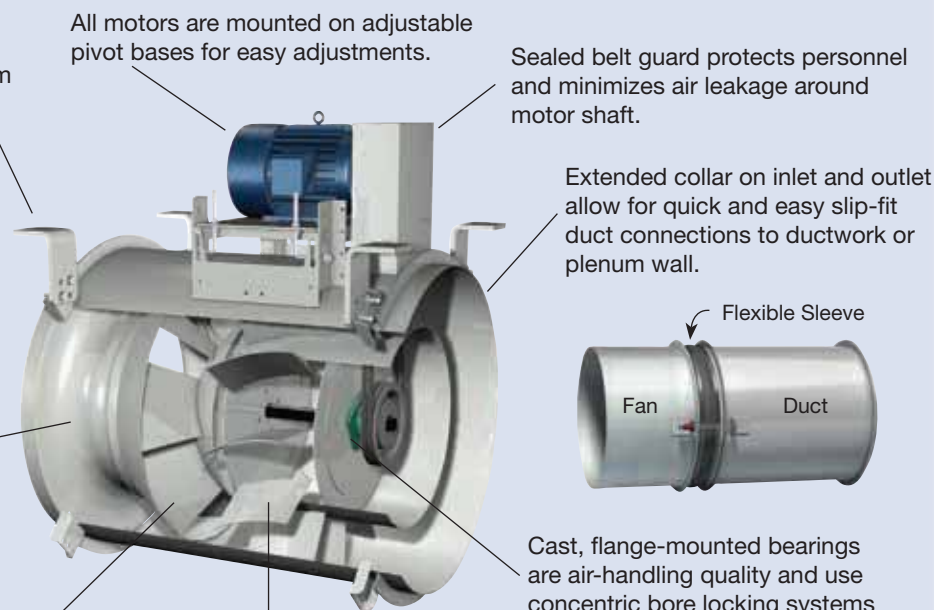

Flexible Universal Mounting System allows for field rotation of motor location.

Permatector™ coating is an industrial grade, electrostatic powder paint. Provides a durable, long lasting finish for interior or exterior applications.

Integral, spun inlet cone provides even airflow into the impeller in ducted or non-ducted applications and helps to reduce system effects associated with uneven duct velocity profiles.

Mixed flow impellers are designed with single-thickness, cambered blades to maximize free area and efficiency. Tight wheel to cone tolerances further improve the mechanical efficiency.

All motors are mounted on adjustable pivot bases for easy adjustments.

Sealed belt guard protects personnel and minimizes air leakage around motor shaft.

Extended collar on inlet and outlet allow for quick and easy slip-fit duct connections to ductwork or plenum wall.

Flexible Sleeve

Fan Duct

Cast, flange-mounted bearings are air-handling quality and use concentric bore locking systems for smooth operation. Bearings are selected for a minimum L<sub>10</sub> life in excess of 80,000 hours at the maximum fan class RPM. (Average life - L<sub>50</sub> 400,000 hours)

Aerodynamically designed straightening vanes improve performance by converting kinetic energy of swirling air into useful static pressure.

## Airflow Profiles



**Centrifugal Fan:** Two 90° deflections, before airflow exits the fan.



**Axial Fan:** Straight-through, nearly linear airflow.



**Mixed Flow QEI Fan:** Slight airflow deflection from straight-through.

## Lower Sound Power, Better Sound Quality

The sound quality of the QEI is as beneficial to low sound design as is the reduced overall sound power. The sound chart compares units of similar outer tube diameters at an operating point of 20,000 cfm with 1.5 inches wg of static pressure (Ps). Tubular centrifugals (green) have dominant tones in the 63 Hz through 250 Hz octave bands, while vane axials (red) have more mid to high frequency sound. The QEI does not have a dominant tone. A bystander would hear a more bland sound that is quieter than a tubular centrifugal or vane axial.

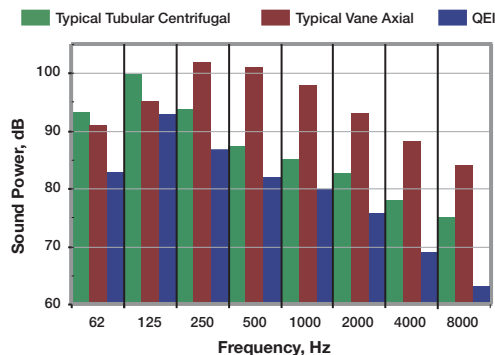





**Applications:**

- Clean Air
- Fume Exhaust
- Spark Resistant Construction

## Model TDI Direct Drive

Model TDI direct drive tube axial fans are best suited for applications moving relatively clean, dry and cool air in commercial and industrial applications.

### Quick Build Performance

Capacities range from 3,000 to 49,000 cfm and up to 1.1 in. wg of static pressure.



**Applications:**

- Clean Air
- Fume Exhaust
- Spark Resistant Construction

## Model TBI-CA Belt Drive

Model TBI-CA belt drive is a good selection where the motor must be mounted out of the airstream. Used with temperatures up to 200°F or contaminated air. Three levels of construction available.

### Quick Build Performance

Capacities range from 1,300 to 95,000 cfm and up to 3.5 in. wg of static pressure.



**Applications:**

- Industrial Space
- Contaminated Air
- High Temperature Process
- UL/cUL Emergency Smoke

## Model TBI-FS Belt Drive

Model TBI-FS belt drive fans have motors out of the airstream. They are a good choice for clean or contaminated airstreams with temperatures up to 400°F. Three levels of construction available.

### Quick Build Performance

Capacities range from 6,000 to 77,000 cfm and up to 4.5 in. wg of static pressure.

UL/cUL 705 Power Ventilators  
E40001 - TDI and TBI-CA

UL/cUL Power Ventilators for Smoke Control Systems  
MH17511 - TBI-FS



Model TDI and TBI-CA are AMCA Licensed for Air Performance

Model TBI-FS is AMCA Licensed for Sound and Air Performance

**Best Available Program**  
10 Days

Standard Construction	TDI	TBI-CA	TBI-FS
Housing - continuously welded, steel	■	■	■
Cast aluminum hub and blades - airfoil	■	■	
Fabricated steel hub and blades - airfoil			■
Belt tube and bearing cover		■	■
Minimum bearing life of L <sub>10</sub> 80,000 hours		■	■
Universal mounting system	■	■	■
Extended lubrication lines	■	■	■
Permatecor™ protective powder coating	■	■	■
Options and Accessories	TDI	TBI-CA	TBI-FS
Motor cover		■	■
Guards - inlet, outlet	■	■	■
Belt guard		■	■
Companion flanges	■	■	■
Isolators - base, hanging, spring	■	■	■
Easy access construction - bolted		■	■
Inspection door - bolted, hinged	■	■	■
Inspection section with removable access panel	■	■	■
NEMA rated disconnect switch	■	■	■
Mounting rails		■	■
Shaft seal		■	■
Inlet bell	■	■	■
Decorative or protective powder coating	■	■	■
Continuous Duty High Temperature			■
UL/cUL Listed Power Ventilators	■	■	■

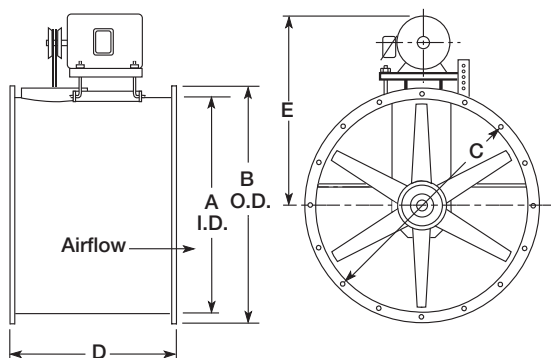

### Dimensions for TDI, TBI-CA, TBI-FS

TDI • Level 3					TBI-CA • Level 3						TBI-FS • Levels 3 and 4					
Model Size	A (ID)	B (OD)	C (BC)	D	Model Size	A (ID)	B (OD)	C (BC)	D	E	Model Size	A (ID)	B (OD)	C (BC)	D	E
18	18 <sup>3</sup> / <sub>8</sub>	21 <sup>1</sup> / <sub>16</sub>	19 <sup>3</sup> / <sub>4</sub>	18	18	18 <sup>3</sup> / <sub>8</sub>	21 <sup>5</sup> / <sub>8</sub>	19 <sup>3</sup> / <sub>4</sub>	22	21 <sup>3</sup> / <sub>4</sub>	3L24, 3H24				23	26
20	20 <sup>3</sup> / <sub>8</sub>	23 <sup>1</sup> / <sub>16</sub>	21 <sup>3</sup> / <sub>4</sub>	19	20	20 <sup>3</sup> / <sub>8</sub>	23 <sup>5</sup> / <sub>8</sub>	21 <sup>3</sup> / <sub>4</sub>	27	26 <sup>1</sup> / <sub>4</sub>	4L24, 4H24	24 <sup>3</sup> / <sub>8</sub>	27 <sup>5</sup> / <sub>8</sub>	25 <sup>3</sup> / <sub>4</sub>	28	28
24	24 <sup>3</sup> / <sub>8</sub>	27 <sup>1</sup> / <sub>16</sub>	25 <sup>3</sup> / <sub>4</sub>	19	24	24 <sup>3</sup> / <sub>8</sub>	27 <sup>5</sup> / <sub>8</sub>	25 <sup>3</sup> / <sub>4</sub>	28	28	3L30, 3H30	30 <sup>3</sup> / <sub>8</sub>	33 <sup>3</sup> / <sub>8</sub>	32	24	29 <sup>3</sup> / <sub>4</sub>
30	30 <sup>3</sup> / <sub>8</sub>	33 <sup>3</sup> / <sub>16</sub>	32	21	30	30 <sup>3</sup> / <sub>8</sub>	33 <sup>5</sup> / <sub>8</sub>	32	24	29 <sup>3</sup> / <sub>4</sub>	4L30, 4H30	30 <sup>3</sup> / <sub>8</sub>	33 <sup>3</sup> / <sub>8</sub>	32	33	32 <sup>3</sup> / <sub>4</sub>
36	36 <sup>3</sup> / <sub>8</sub>	39 <sup>3</sup> / <sub>16</sub>	38	21	36	36 <sup>3</sup> / <sub>8</sub>	39 <sup>5</sup> / <sub>8</sub>	38	29	33 <sup>3</sup> / <sub>4</sub>	3L36, 3H36	36 <sup>3</sup> / <sub>8</sub>	39 <sup>3</sup> / <sub>8</sub>	38	29	33 <sup>3</sup> / <sub>4</sub>
42	42 <sup>1</sup> / <sub>2</sub>	45 <sup>3</sup> / <sub>4</sub>	44 <sup>1</sup> / <sub>4</sub>	27	42	42 <sup>1</sup> / <sub>2</sub>	45 <sup>3</sup> / <sub>4</sub>	44 <sup>1</sup> / <sub>4</sub>	30	37 <sup>1</sup> / <sub>4</sub>	4L36, 4H36	36 <sup>3</sup> / <sub>8</sub>	39 <sup>3</sup> / <sub>8</sub>	38	34	35 <sup>1</sup> / <sub>4</sub>
48	48 <sup>1</sup> / <sub>2</sub>	52 <sup>3</sup> / <sub>4</sub>	50 <sup>3</sup> / <sub>4</sub>	27	48	48 <sup>1</sup> / <sub>2</sub>	52 <sup>3</sup> / <sub>4</sub>	50 <sup>3</sup> / <sub>4</sub>	33	40 <sup>1</sup> / <sub>2</sub>	3L42, 3H42	42 <sup>1</sup> / <sub>2</sub>	45 <sup>3</sup> / <sub>4</sub>	44 <sup>1</sup> / <sub>4</sub>	30	37 <sup>1</sup> / <sub>4</sub>
					54	55	59 <sup>1</sup> / <sub>4</sub>	57 <sup>1</sup> / <sub>4</sub>	37 <sup>1</sup> / <sub>2</sub>	47 <sup>1</sup> / <sub>4</sub>	4L42, 4H42	42 <sup>1</sup> / <sub>2</sub>	45 <sup>3</sup> / <sub>4</sub>	44 <sup>1</sup> / <sub>4</sub>	39	40
					60	61	65 <sup>1</sup> / <sub>4</sub>	63 <sup>1</sup> / <sub>4</sub>	40	50 <sup>3</sup> / <sub>4</sub>	3L48, 3H48	48 <sup>1</sup> / <sub>2</sub>	52 <sup>3</sup> / <sub>4</sub>	50 <sup>3</sup> / <sub>4</sub>	33	40 <sup>1</sup> / <sub>2</sub>
											4L48, 4H48	48 <sup>1</sup> / <sub>2</sub>	52 <sup>3</sup> / <sub>4</sub>	50 <sup>3</sup> / <sub>4</sub>	44	45 <sup>1</sup> / <sub>2</sub>
											3L54, 3H54	55	59 <sup>1</sup> / <sub>4</sub>	57 <sup>1</sup> / <sub>4</sub>	37 <sup>1</sup> / <sub>2</sub>	47 <sup>1</sup> / <sub>4</sub>
											4L54, 4H54	55	59 <sup>1</sup> / <sub>4</sub>	57 <sup>1</sup> / <sub>4</sub>	48	49 <sup>1</sup> / <sub>4</sub>

All dimensions are in inches.

ID = Inside Diameter  
 OD = Outside Diameter  
 BC = Bolt Center



Arrangement 9



Model VAB is AMCA Licensed for Air Performance

Model	Best Available Program
Class I Sizes 18 - 48	10 Days

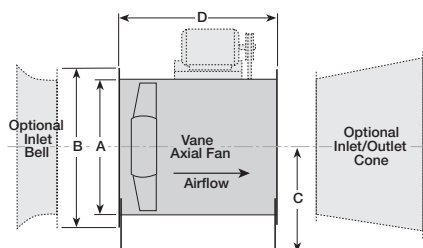

### Dimensions for VAB

Model Size	A	B	C	D
18	18 <sup>3</sup> / <sub>8</sub>	21 <sup>3</sup> / <sub>4</sub>	13 <sup>1</sup> / <sub>2</sub>	32
20	20 <sup>3</sup> / <sub>8</sub>	23 <sup>3</sup> / <sub>4</sub>	15	32
24	24 <sup>3</sup> / <sub>8</sub>	27 <sup>3</sup> / <sub>4</sub>	17 <sup>1</sup> / <sub>2</sub>	36
30	30 <sup>3</sup> / <sub>8</sub>	33 <sup>3</sup> / <sub>4</sub>	21 <sup>1</sup> / <sub>4</sub>	40
36	36 <sup>3</sup> / <sub>8</sub>	39 <sup>3</sup> / <sub>4</sub>	25	40
42	42 <sup>1</sup> / <sub>2</sub>	47	29	44
48	48 <sup>1</sup> / <sub>2</sub>	53	34	48

All dimensions are in inches.

## Model VAB Belt Drive

Vane axial fans feature the advantages of final system balancing, motor access, manually adjustable blade pitch, economical future upgrading, and the capability to operate in airstream temperatures up to 200°F.

### Quick Build Performance

Capacities range from 2,000 to 70,000 cfm and up to 7 in. wg of static pressure.

Standard Construction
Housing - continuously welded, steel
Cast aluminum hub and blades
Straightening vanes
Final assembly vibration analysis
Extended lubrication lines
Permator™ protective powder coating
Options and Accessories
Motor cover
Guards - inlet, outlet
Belt guard
Companion flanges - inlet, outlet
Inlet/outlet cone
Isolators
Inspection section
NEMA rated disconnect switch
Inlet bell
Horizontal or vertical mounting options
Decorative or protective powder coating
UL/cUL Listed Power Ventilators

### Mounting Options

#### Horizontal Base



Heavy-gauge steel support legs welded to the fan are punched to accept neoprene or spring vibration isolators.

#### Horizontal Ceiling Hung



Brackets welded to the fan housing for horizontal ceiling hung applications are punched to accept hanging neoprene or spring isolators.

#### Vertical Base or Suspension Brackets



Brackets welded to the fan housing for vertical base mount or vertical ceiling hung applications are punched to accept vibration isolators. Customer must specify one of the mounting arrangements shown below.





# whole health.

Efficient **air** systems for sustainable hospitals.

- 1 *Mixed Flow Fan*
- 2 *Combination Louver/ Damper*
- 3 *Utility Fan*
- 4 *Spun Aluminum Roof Exhaust*
- 5 *Packaged Ventilation System*
- 6 *Laboratory Exhaust System*
- 7 *Centrifugal Inline Fan*
- 8 *Energy Recovery Ventilator*
- 9 *Spun Aluminum Upblast Exhaust Fan*
- 10 *Centrifugal Supply Fan*
- 11 *Louvered Equipment Screen*
- 12 *Make-Up Air*
- 13 *Centrifugal Inline Fan/ Fire Smoke Damper*
- 14 *Kitchen Hood*
- 15 *Utility Distribution System*

Today's hospital ventilation needs are more dynamic and demanding than ever, with increased focus on energy efficiency and sustainable building design concepts. To meet complex and interrelated demands throughout a medical facility, you must equip for a wide variety of critical, specialized applications — public areas, offices, surgery suites, highly sensitive equipment, patient rooms, laboratories, kitchen and cafeteria. Only an integrated HVAC system can provide the reliability and performance a hospital needs. Greenheck offers a comprehensive line of products, designed to work together, effectively, with energy efficiency and quiet operation, and the added benefit of simplified installation to save time and costs. We offer more products with certifications from AMCA, UL, ETL, AHRI and CSA than any other manufacturer. And, many Greenheck products can help attain LEED credits. Take a holistic and sustainable approach for your hospital project — contact your Greenheck representative today.

**Learn more at [greenheck.com/4hospital](http://greenheck.com/4hospital)**

Fans & Ventilators | Centrifugal & Vane Axial Fans | Energy Recovery Ventilators  
Packaged Ventilation Systems | Make-up Air Units | Kitchen Ventilation Systems  
Dampers | Louvers | Fume & Lab Exhaust Systems | Coils

715.359.6171  
[greenheck.com](http://greenheck.com)



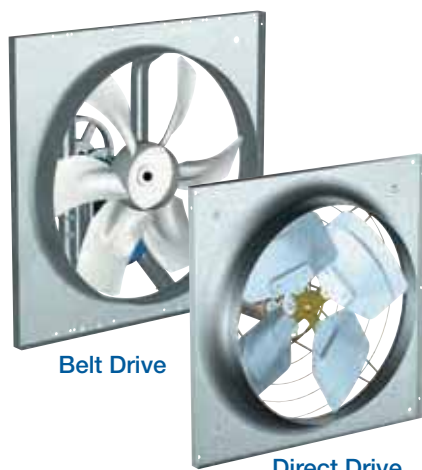

Belt Drive

Direct Drive

UL/cUL 705 Power Ventilators  
E40001 - SE1/SS1, SE2/SS2, SCE3/SCS3, SBE/SBS,  
SBCE/SBCE



UL/cUL Listed 705 is standard on In Stock SE1 and SBE models.

Model S1, S2, SC3, SB and SBC are AMCA Licensed for Sound and Air Performance

Model	Best Available Program
SE-8 through 12, 16 and 20	In Stock
SBE-24 through 36	
All SE/SS, SCE/SCS, SBE/SBS, SBCE/SBCE up through size 48	3 Days
All SE/SS, SCE/SCS, SBE/SBS, SBCE/SBCE sizes 54 and larger	5 Days

## Model SE, SS, SCE, SCS Direct Drive and SBE, SBS, SBCE, SBCE Belt Drive

Sidewall propeller fans are designed to **exhaust** or **supply** high volumes of air from commercial and industrial buildings. Fan panels allow for electrical passage to either side of panel for easy wiring.

### Quick Delivery / Quick Build Performance

Capacities range from 100 up to 87,000 cfm and 1 in. wg of static pressure.

		Direct Drive		Belt Drive		
Standard Construction		SE SS	SCE SCS	SBE SBS	SBCE SBCE	
Fan panel and drive frame - galvanized steel		■	■	■	■	
Propeller construction	Level 1	Stamped aluminum				
		Fabricated steel			■	
	Level 2	Fabricated steel		■		
	Level 3	Fabricated steel		■		
	Cast aluminum		■		■	
Corrosion-resistance fasteners		■	■	■	■	
Reversible			■		■	
Ball bearing motor - 1/4 hp and larger		■	■	■	■	
Three speed motor (sizes 8 through 12)		■				
Adjustable motor pulley				■	■	
Options and Accessories		Stock	SE SS	SCE SCS	SBE SBS	SBCE SBCE
Vari-Green® motor - 80% turndown, 85% efficient <i>Available as standard on select sizes</i>		✓	■			
Dampers		✓	■	■	■	■
Wall housing - up through size 24		✓	■	■	■	■
Wall collar - Stock up through size 36		✓	■	■	■	■
Weatherhood 45° - up through size 24 and size 36		✓	■	■	■	■
Weatherhood 90° - up through size 16 and size 24		✓	■	■	■	■
Motor side guard - size 20 through 30		✓	■	■	■	■
OSHA motor side guard - size 16		✓	■	■	■	■
Louver/Fire damper - size 20 through 42					■	■
Damper guard			■	■	■	■
Horizontal mounting			■	■	■	■
Wiring - pigtails			■	■	■	■
Lube lines					■	■
Filters - 2 inch aluminum, washable - <i>supply only</i>			■	■	■	■
NEMA rated disconnect switch			■	■	■	■
Dual drives					■	■
Relubricatable bearings					■	■
OSHDP rated			■	■	■	■
Decorative or protective powder coating			■	■	■	■
UL/cUL Listed Power Ventilators			■	■	■	■



Select sizes and models with the Vari-Green® motor are available in stock.

## Direct Drive Models: SE, SS, SCE, SCS

Level 1: Sizes 8-12

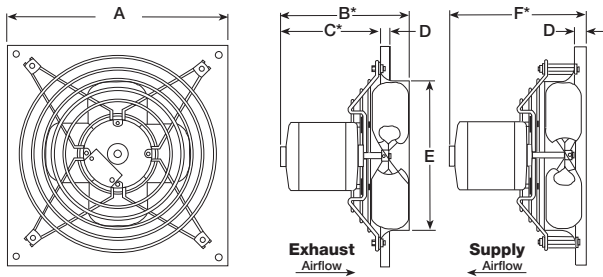

Level 1: Sizes 12-24

Level 2: Sizes 16-54

Level 3: Sizes 20-54

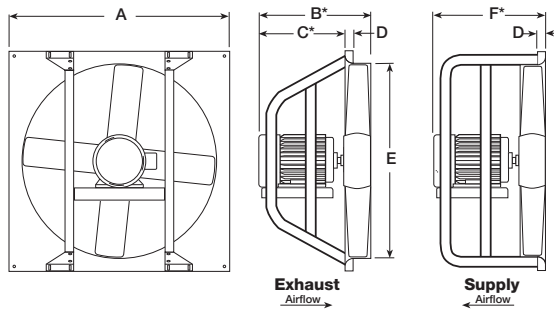

### Dimensions for Direct Drive

Model Size	Fan Panel		Airflow			
	A	D	Exhaust		Supply	
	Sq. Size	Flange	B*	C*	E	F*
8	13	1	7	5	8 <sup>5</sup> / <sub>8</sub>	8
10	15	1	8 <sup>3</sup> / <sub>4</sub>	5	10 <sup>5</sup> / <sub>8</sub>	8
12	18	1	10 <sup>3</sup> / <sub>4</sub>	8 <sup>3</sup> / <sub>4</sub>	12 <sup>3</sup> / <sub>8</sub>	13 <sup>3</sup> / <sub>8</sub>
14	20	1	11 <sup>1</sup> / <sub>4</sub>	8 <sup>1</sup> / <sub>2</sub>	14 <sup>3</sup> / <sub>8</sub>	14 <sup>1</sup> / <sub>4</sub>
16	22	1	11 <sup>3</sup> / <sub>4</sub>	10 <sup>1</sup> / <sub>4</sub>	16 <sup>3</sup> / <sub>8</sub>	14
18	24	1	14	10 <sup>7</sup> / <sub>8</sub>	18 <sup>3</sup> / <sub>8</sub>	14 <sup>1</sup> / <sub>4</sub>
20	26	1	17 <sup>1</sup> / <sub>4</sub>	13 <sup>1</sup> / <sub>2</sub>	20 <sup>1</sup> / <sub>2</sub>	18
24	32	1 <sup>1</sup> / <sub>4</sub>	20	13 <sup>1</sup> / <sub>2</sub>	24 <sup>3</sup> / <sub>8</sub>	21
30	38	1 <sup>1</sup> / <sub>4</sub>	20 <sup>1</sup> / <sub>2</sub>	16 <sup>3</sup> / <sub>8</sub>	30 <sup>5</sup> / <sub>8</sub>	21 <sup>3</sup> / <sub>4</sub>
36	44	2	20 <sup>1</sup> / <sub>2</sub>	16 <sup>3</sup> / <sub>8</sub>	36 <sup>5</sup> / <sub>8</sub>	28
42	50	2	26	18 <sup>1</sup> / <sub>4</sub>	42 <sup>5</sup> / <sub>8</sub>	28
48	56	2	26 <sup>5</sup> / <sub>8</sub>	20 <sup>5</sup> / <sub>8</sub>	48 <sup>5</sup> / <sub>8</sub>	28 <sup>1</sup> / <sub>2</sub>
54	62	2	28	22 <sup>7</sup> / <sub>16</sub>	55 <sup>3</sup> / <sub>8</sub>	30 <sup>1</sup> / <sub>8</sub>

All dimensions are in inches.  
\*Varies with motor selection.

## Belt Drive Models: SBE, SBS, SBCE, SBCE

Level 1: Sizes 20-54

Level 2: Sizes 20-60

Level 3: Sizes 24-30

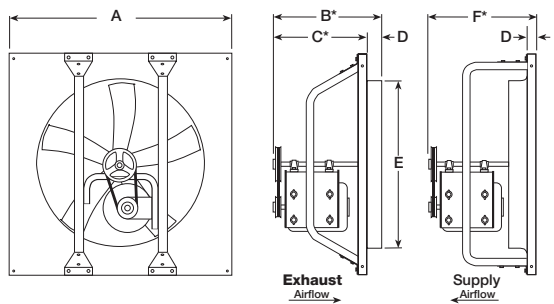

Level 3: Sizes 36-72

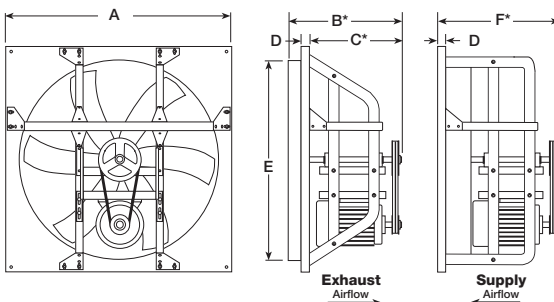

### Dimensions for Belt Drive

Model Size	Fan Panel		Exhaust				Supply		
	Sq. Size	Flange	Levels 1 and 2		Level 3		All Levels	Levels 1 and 2	Level 3
			B*	C*	B*	C*			
20	26	1	19 <sup>1</sup> / <sub>2</sub>	16 <sup>1</sup> / <sub>4</sub>	—	—	20 <sup>1</sup> / <sub>2</sub>	20	—
24	32	1 <sup>1</sup> / <sub>4</sub>	19 <sup>1</sup> / <sub>2</sub>	16 <sup>3</sup> / <sub>8</sub>	19	15 <sup>5</sup> / <sub>8</sub>	24 <sup>5</sup> / <sub>8</sub>	20	20 <sup>1</sup> / <sub>2</sub>
30	38	1 <sup>1</sup> / <sub>4</sub>	22 <sup>1</sup> / <sub>2</sub>	18 <sup>3</sup> / <sub>4</sub>	21 <sup>1</sup> / <sub>2</sub>	17 <sup>1</sup> / <sub>4</sub>	30 <sup>5</sup> / <sub>8</sub>	21	20
36	44	2	21 <sup>1</sup> / <sub>2</sub>	16 <sup>1</sup> / <sub>2</sub>	28	23	36 <sup>5</sup> / <sub>8</sub>	22	27
42	50	2	25	20	28	23	42 <sup>3</sup> / <sub>4</sub>	25 <sup>1</sup> / <sub>2</sub>	29 <sup>1</sup> / <sub>4</sub>
48	56	2	25	19	31 <sup>1</sup> / <sub>2</sub>	27 <sup>1</sup> / <sub>2</sub>	48 <sup>3</sup> / <sub>4</sub>	25 <sup>1</sup> / <sub>2</sub>	30 <sup>1</sup> / <sub>2</sub>
54	62	2	25	19 <sup>1</sup> / <sub>2</sub>	35 <sup>3</sup> / <sub>4</sub>	30 <sup>1</sup> / <sub>4</sub>	55 <sup>1</sup> / <sub>4</sub>	24	36 <sup>1</sup> / <sub>4</sub>
60	68	2	28	21 <sup>1</sup> / <sub>16</sub>	35	28 <sup>7</sup> / <sub>16</sub>	61 <sup>1</sup> / <sub>4</sub>	24	35 <sup>1</sup> / <sub>2</sub>
72	82	2 <sup>1</sup> / <sub>8</sub>	—	—	35	28 <sup>1</sup> / <sub>4</sub>	73 <sup>1</sup> / <sub>4</sub>	—	35 <sup>1</sup> / <sub>2</sub>

All dimensions are in inches.  
\* Varies with motor selection.

## Options and Accessories for Sidewall Propeller Fans

### Wall Housing

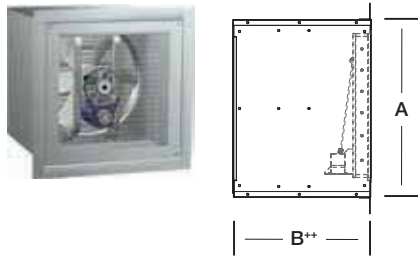

### Wall Collar

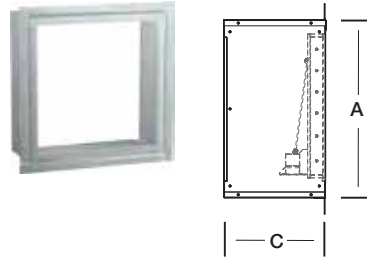

### 45° Weatherhood

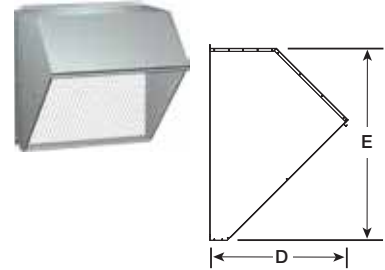

### 90° Weatherhood

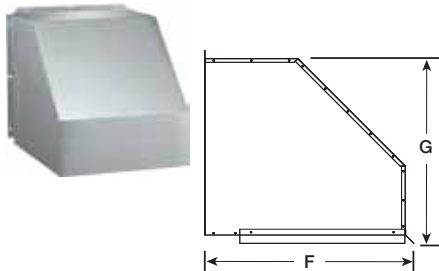

### Motor Side Guards

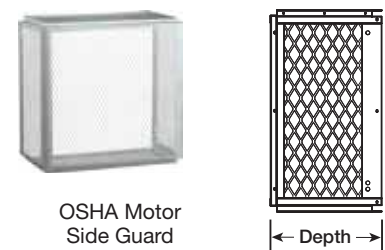
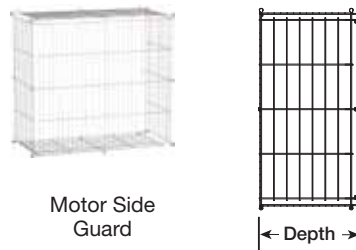

### Damper Guard

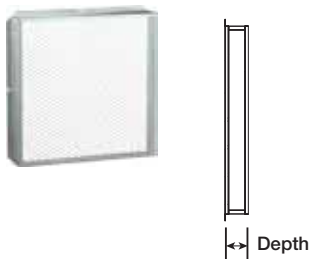

Optional  
Direct Drive  
Configuration



Optional  
Belt Drive  
Configuration

## Dimensions

Model Size	Wall Opening*	Wall Housing & Collars			Width	Weatherhood				Motor Side Guard Depth	OSHA Motor Side Guard Depth	Damper Square	Damper Guard Depth
		Square	Length			45°	90°						
			A	B++				C	D				
8	14¼	13¼	19	16⅞	10½	13¼	11¼	16⅞	12	—	9⅞	10	5½
10	16¼	15¼	19	16⅞	12½	14⅞	13⅞	18½	14	—	10	12	6½
12	19¼	18¼	23	16⅞	14½	16⅞	15⅞	20⅞	16⅞	—	12	14	5⅞
14	21¼	20¼	26	18⅞	16½	17½	17⅞	22½	18⅞	—	12	16	6⅞
16	23¼	22¼	27	18⅞	18½	19⅞	19⅞	25	20⅞	—	12	18	6¾
18	25¼	24¼	28	18⅞	20½	22	21⅞	27½	22⅞	—	12	20	6
20	27¼	26¼	32	18⅞	22½	24¾	23⅞	29¾	24⅞	17⅞	17¾	22	6½
24	33¼	32¼	37	18⅞	29⅞	26⅞	30⅞	36	31¼	19½	20	26	6⅞
30	39¼	38¼	38	18⅞	35⅞	29⅞	36½	40⅞	37⅞	22½	21¾	32	6½
36	45¼	44¼	39	18¼	41⅞	33	42½	45½	43⅞	23⅞	24¼	38	6¼
42	51¼	50⅞	44	18¼	47⅞	35¼	48½	49¼	49⅞	25⅞	28½	44	10
48	57¼	56⅞	44	18⅞	53¼	40⅞	54⅞	55½	56	28⅞	28¼	50	9
54	63¼	62⅞	52	20⅞	59½	44¾	60⅞	61¼	62¼	—	34¼	56	7½
60	69¼	68⅞	54	21	65⅞	48⅞	67	66½	68⅞	—	34¼	62	7¼
72	84¼	83⅞	60	22	78⅞	53¼	79½	72⅞	80⅞	—	34¼	74	7½

All dimensions are in inches.

\*Opening is for fan and accessories to fit.

++Indicates short wall housing dimension. Add 6 inches for long wall housing. Add 10 inches for louver/fire damper.



**Best  
Available  
Program**

**In Stock**

## Model CBF Direct Drive

Cement block fans are designed for economy and reliability in small size, high volume applications. Efficient propeller, venturi, and motor design results in low sound levels with minimal restriction to airflow. Works great for ventilating equipment rooms, plumbing and electrical chases.

### Quick Delivery Performance

Capacities range from 300 to 500 cfm and 0.4 in. wg of static pressure.

#### Standard Construction

Housing - galvanized steel
Fits in place of a standard 16 by 8 inch concrete block
Mountable in any wall construction
Mounting flanges for easy installation
Grille - galvanized steel
UL/cUL Recognized motor

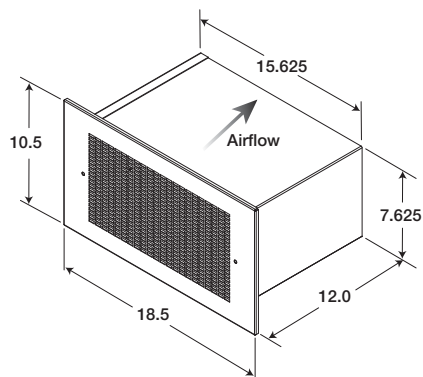

All dimensions are in inches.